

South Dakota State University

Open PRAIRIE: Open Public Research Access Institutional Repository and Information Exchange

Electronic Theses and Dissertations

1893

A Study of the Forage Plants of South Dakota with Their Fungous and Insect Enemies

David Griffiths
South Dakota State University

Follow this and additional works at: <https://openprairie.sdstate.edu/etd>



Part of the [Agronomy and Crop Sciences Commons](#), [Botany Commons](#), and the [Plant Pathology Commons](#)

Recommended Citation

Griffiths, David, "A Study of the Forage Plants of South Dakota with Their Fungous and Insect Enemies" (1893). *Electronic Theses and Dissertations*. 4.
<https://openprairie.sdstate.edu/etd/4>

This Thesis - Open Access is brought to you for free and open access by Open PRAIRIE: Open Public Research Access Institutional Repository and Information Exchange. It has been accepted for inclusion in Electronic Theses and Dissertations by an authorized administrator of Open PRAIRIE: Open Public Research Access Institutional Repository and Information Exchange. For more information, please contact michael.biondo@sdstate.edu.

A S T U D Y

of the

FORAGE PLANTS OF SOUTH DAKOTA,

with Their Fungous and Insect Enemies.

by

David Griffiths, B.S.,

-- oOo --

Presented for M. S. Degree.

At the Agricultural College of South Dakota.

August, 1893.

I N T R O D U C T I O N .

The main object of this study being a better acquaintance with fungous parasites, the work on the host plants has been considerably abridged in order that the discussion might be shortened. It was the plan at first to include in this paper a carefully written description of each of the principal forage plants of the state. The futility of such a plan, however, soon became apparent, and it was accordingly decided to omit the description and include simply Distribution, Habitat, Value as Forage, and the Fungous Parasites of each host. There are, therefore, several of our best forage plants omitted from this paper because they were not found diseased.

With the exception of five or six species, all of the material here described was collected during the summer of 1892. The greater part of the collecting was done by myself, but many contributions were made

by T. A. Williams, E. N. Wilcox, and J. J. Thornber. While at the University of Nebraska, last winter, P.A. Rhydburg kindly allowed me to examine his collection of grasses from the Black Hills of South Dakota. From this source I obtained two very valuable things, a *Puccinia* and an *Erysiphe*. All but four of the species described here were collected on the east side of the Missouri river, within the borders of South Dakota. The other four were collected in the Black Hills of this state.

Nearly all of the determinations were made at the State University of Nebraska during the winter of 1892-93. While there access was gained to a valuable herbarium, literature, and apparatus, which could not have been obtained otherwise.

The determination of species was made principally by the aid of the following literature: "Sylloge Fungorum" (P.A.Saccardo), "Fungi Italica" (P.A.Saccardo), "North American Perenomycetes" (Ellis & Everhart), "British Uredineae and Ustilagineae" (Plowright), "Parasitic Fungi of Illinois" (Burrill), "Genera Perenomycetum" (P.A.Saccardo), "Provisional Host-Index of the Fungi of the United States" (Farlow & Seymour),

"Journal of Mycology," and "The Botanical Gazette."

The chemical composition of the host plants was gleaned from three sources, Bulletin No. 12, of the State Agricultural College and Experiment Station of Colorado, "Grasses and Forage Plants of the United States"---a special bulletin by the United States Department of Agriculture, and "Zusammensetzung und Verdaulichkeit der Futtermittel" (Diedrich & König).

The nutritive ratio has been computed according to the following formula: $(1/3 \text{ of Fat} \times 5) + (1/2 \text{ of Albuminoid Nitrogen} \times 5) + (\text{Nitrogen free extract}) =$ nutritive ratio.

The study is divided into two parts. Part I contains a brief popular description of the principal groups of the fungous enemies of forage plants, with methods for keeping them in check. Part II, the principal part of the study, deals, as has been stated, with the distribution, habitat, value as forage, and the fungous enemies of the host plants.

In all cases, specimens have been mounted and placed in the College herbarium, while the majority of the specimens have been collected in duplicate for exchange.

A list, consisting of the names of about three hundred twenty-five insects, which have been recorded as being especially injurious to grasses, has been appended to this study. A list of one hundred insects feeding on the clovers, and another list of one hundred twenty-five insects feeding on the small grains, have also been prepared; but it has not been thought advisable to insert anything but the grass insects at the present time.

These lists were prepared by working over entomological literature at the State University of Nebraska. A few of the works consulted are given below. "A Contribution Toward a Monograph of the Family Noctuidae" (Bulletin No. 38, U.S. Nat'l Museum), "Special Bulletins," (U.S. Dept. Agr., Div. Ento.) "Insect Life," "Transactions of the Department of Agriculture of Illinios," "New York Entomological Reports," "A Bibliography of American Economic Entomology," (Walsh & Riley), "A Catalogue of New Jersey Insects," (Smith), "Canadian Entomologist," "American Entomologist," "Butterflies of the Eastern United States, and Canada," (Scudder), "Bibliographical Catalogue of the Described Transformations of North American

Lepidoptera" (Bull. No. 35, U. S. Nat'l Museum),
"Station Bulletins" of Nebraska, Iowa, and Ohio,
"Psyche," and "Orthoptera of New England."

The classification of the insects was made according to "Genera in Zoology" (Bull. No. 19 of the U. S. Nat'l Museum), and the "Catalogue of New Jersey Insects" (Smith).

David Griffiths.

P A R T I

PERONOSPORACEAE.

(Mildews and White Rusts.)

On account of their habits of development within the host, these are very difficult to study in their vegetative state. They have, like the perisporiaceae, two kinds of spores, but, unlike them, they produce the asexual small spores on the outside and the sexual or large resting spore within the tissues of the host. The resting spore, which carries the plant over winter, is a brown, globular one-celled oogone which remains within the tissues until they decay in the spring.

Remedies.

Were it desirable, it would be very difficult to find any specific remedy for this class of fungous diseases because they, like the rusts, develop entirely within the tissues of the host. Nothing but general sanitation can be recommended after the fungus has entered the host plant. But one species of this order was observed on forage plants in this vicinity last year. This one was rather a beneficial than an in-

jurious fungus. It was quite common on Foxtail (*Setaria viridis*), which is an injurious weed, and was sometimes found on *S. Italica*, one of the cultivated species but not to any great extent. It is of course possible that this may become injurious to any of the cultivated Foxtails in the future, but the character of its development thus far indicates a beneficial rather than an injurious fungus. To many other plants this is a very injurious order of fungi. The Grape Peronospora, for instance, is a very injurious species and is controlled by spraying ^{the vines when the} conidia are germinating upon the leaves and preparing to enter their tissues. Should this class ever become very injurious on forage plants they can be kept in check by spraying with the Bordeaux mixture, described under the Blights.

-- oOo --

PERISPORIACEAE. (Blights.)

These plants live almost entirely on the outside of the host. They are composed of long, branching filaments which form a white film over the surface of the leaves. The vegetative portion, or hyphae, lie ver

close to the epidermis of the leaves and send out haustoria, or small suckers, from their under sides. These, it is thought, do not penetrate the cells but only lie very close to them and extract nutriment in that way. These hyphae soon send up erect branches which produce series of globular or elliptical conidia by successive constrictions. These finally become separated from the parent plant, are wafted by the wind upon some portion of the host, germinate, and rapidly produce a new individual plant. Later in the season, the hyphae produce perithecia, which are large brown, globular bodies having variously curved and twisted appendages which intertwine with the hyphae to fasten them to the parent plant. These fall with the leaves in autumn and carry the plant over winter. In the spring, the perithecia break open and allow the exit of their asci and included spores.

Remedies.

This order of fungi is not so destructive to the grasses and forage plants as it is to other plants. Only two species were found on forage plants the past season one on grasses and the other on the Legumes. They can

be treated with the Bordeaux mixture, which consists of 4 lbs. lime and 6 lbs. copper sulphate to 22 gals. of water. As these fungi exist only on the outside of the host, they can be effectually gotten rid of by thoroughly spraying with this solution. The fungus, however, need not cause much alarm as it appears too late to cause damage to anything in the shape of forage plants unless it be pastures late in the fall, but this is not at all probable.

-- oOo --

PYRENOAMYCETES. (Black Fungi.)

This order of exceedingly destructive fungous parasites is closely related to the Blights but unlike them they have hard coriaceous tissues. Thus far three genera have been found to infect forage plants in this state, *Epichloe*, *Claviceps*, and *Phyllochora*. These are very injurious to several species of grasses, and one, (*Claviceps*), is also injurious to the stock that feed upon the grasses which have been affected by the fungus. In Kansas and Nebraska, hundreds of cattle and horses have been killed by eating hay affected by this fungus.

As an example of the development of this order of injurious, parasitic fungi, we will briefly describe that of common Ergot (*Claviceps purpurea*). The first stage of this species is a dense growth of mycelia upon and within the young ovary of the plant. After a considerable growth of mycelia has taken place, erect hyphae are produced which bear, at their summits, a few oval or elliptical, hyaline conidia which are brushed up against or are carried by wind and insects to the ovaries of neighboring plants. They then germinate, enter the young ovaries, and there produce mycelia, hyphae, and conidia the same as before. While the hyphae and conidia are being produced the mycelia continues to develop into a black horn-like, mass beneath the ovary which is forced upward a distance of one-half to three-quarters of an inch. These are fully developed about the time that the plant ripens its seed. A short time after they become fully developed, these sclerotia fall to the ground, become partially covered with dirt and debris, and remain in a dormant stage until about the first of May, when the mycelia again begin a development which results in the production of a few small branches which grow upward from the under

side of the sclerotium and ^{which} have small globular heads at their summits. Within these heads are perithecia which contain long, cylindrical, hyaline, eight-spored, asci. The spores germinate under favorable conditions and produce sphacelia, which is the last stage in the round of life of the fungus.

Remedies.

Cleanliness is the only remedy known for these fungi. All rubbish and especially all of the plants upon which these parasites are liable to thrive should be kept cut close to the ground so as to prevent the production of sclerotia, spores, etc. For instance, if Ergot is the troublesome fungus, all of the Wheat Grasses (*Agropyri*) especially, should be cut before they have a chance to produce sclerotia.

-- oOo --

UREDINEAE. (The Rusts.)

This order of parasitic fungi is, with a few exceptions, confined to the flowering plants. The different species appear on one or a few closely related hosts. They are the most injurious of all the fungi; causing more damage and being more difficult to control

than any of the other diseases.

The development and the life history of the rusts are very complicated and interesting. Until late years there has been much dispute and misunderstanding among botanists regarding them; but DeBary, Plowright, and others have, it is thought, solved the problem of their development. They pass through from two to four distinct stages in the course of their life history, - each stage being marked by the production of a spore which in its turn germinates and gives rise to the succeeding stage which to all outward appearance is entirely different from the stage which produced it. As an illustration we will notice the various stages of development in the common wheat rust (*Puccinia graminis*).

If one should visit an old straw pile or a stubble field where rust occurred the previous year, about the time that the snow is disappearing in the spring, and examine the straw carefully with the microscope, he would find spores of what is popularly known as black rust. These are brown, elliptical bodies with a single transverse partition in the center and with a short stalk upon which they grew, fastened to one end. Close

examination will reveal the fact that these spores have germinated and sent out a short growth somewhat exceeding the length of the spore. These growths or mycelia produce at their extremities from one to three or four small sporidia. These sporidia or small spores are wafted about by the winds like fine dust, and where the Barberry (*Berberis vulgaris*) is common they are carried to its leaves, where they germinate and send a mycelial growth into the tissues of the plant. After entering, the mycelium grows very rapidly in all directions within a limited radius, finally distending the leaf and causing bright yellow calluses, upon the under surface of which occur minute elevations. The epidermis of the leaf is soon ruptured at these elevations, sometimes irregularly, but generally its edges are fashioned into beautifully recurved scollopes. If a cross section is made through these openings in the epidermis, they will be found to be cup shaped, filled with long chains of spores, Plate I, Fig. 3 & 4, and surrounded by an epithelial coat of more or less hexagonal gutulate cells. Plate I, Fig. 5.

The spores of this stage are carried by the wind to the young wheat or grass plants where they germinate

and enter the leaves, generally through the stomata. Here they ramify in all directions within a very limited area, forming a dense network of mycelia, much resembling parenchyma tissue. As these develop, the epidermis of the plant is gradually distended and finally ruptured, Plate I, Fig. 1 & 2, exposing the ends of many erect hyphae which bear at their summits minute, elliptical or oval, echinulate, yellow spores, uredospores, Plate I, Fig. 6. This stage is known as the red rust stage of the wheat. The hyphae continue producing red rust spores for sometime by transverse constrictions at their apices and finally from the same hyphae the large, brown, two-celled, smooth teleutospore is produced, which carries the plant over winter. Plate I, Fig. 7 & 8.

While the above method is the general and apparently the natural plan of development of this order of fungous parasites, it is by no means without exceptions. Indeed, it might be asserted that what we ordinarily consider as the natural method is itself an exception, for since the Barberry does not occur in all regions where the wheat rust prevails, one of two things is certain, viz: that the fungus is able to leave out

one stage of its development or that there are other plants upon which that stage occurs. According to our best knowledge of the subject, at present, the former appears to be the most probable conclusion. Many of the rusts have been carefully studied and all of their intermediate stages have been found; but the majority of the intermediate forms of the various species, if they occur, are yet to be discovered.

Remedies.

It will be seen from the description that these fungi develop almost entirely within the tissues of the host plant. It is therefore very doubtful whether we shall ever find a fungicide which will destroy the fungus without at the same time destroying the host which we are anxious to protect. As the Aecidiospores germinate upon the surface of the host, it would appear quite probable that by spraying we might destroy them; but the abundance of spore formation, the constant activity of the wind, the difficulty of manipulation, and the uncertainty of our knowledge regarding the development has, thus far, baffled all attempts in this direction. Dr. Kellerman, formerly of the State Agricultural College of Kansas, conducted an

extended series of experiments during May and June of 1891 to test the value of fungicides as preventives for the development of the rusts of small grains, with no beneficial results. Indeed, his experiments show that spraying favors rather than retards the development of rust.

In spite of the fact that spraying has thus far been unsuccessful, much can be done to prevent the development of rust by general sanitation. The common wheat rust, for instance, grows on many of the common weeds of our fields and roadsides. Squirrel-tail Grass (*Hordeum jubatum*) and the Quack Grasses (*Agropyrium* spp) are always more or less affected by the common grass and grain rusts. If the fields and roadsides were kept free from these, it would check the development of myriads of spores which would otherwise winter over in the grass and rubbish and be ready in the spring to devastate the succeeding crop of grain. All rubbish, straw and stubble of affected grain should be carefully burned, and rotation of crops should be diligently practiced.

USTILAGINEAE. (Smuts.)

The smuts are another order of parasites that live entirely within the tissues of the host. The vegetative portion of the fungus, consisting of jointed and branching filaments, ^{which} ramify through the intercellular spaces of the plant and send out suckers into the cells much like the Peronosporae. These mycelia of the fungus develop with the development of the host and penetrate all portions of the plant until it reaches the place of spore formation. It is supposed that the spores are in all cases produced in asci, but these latter have been found in only a few species. The place of spore formation depends upon the species. The majority of species produce their spores within the ovary, while in others they may develop in any portion of the host. The place of spore formation, however, is uniform for any single species. Whenever the host plant is a perennial, the smut is also, as the mycelia winter over in the tissues. With an annual host, however, it is entirely different. The spores germinate while in very close proximity to the germinating seed upon which it is to feed. The smut spore upon beginning

its growth sends out a short promycelia which enters the seed and thence grows upward through the whole plant.

Remedies.

For the perennial portion of the order Ustilagineae no remedies except general sanitation and the destroying of the affected hosts can be given. The annual ones, however, although much more numerous and destructive, are comparatively easy to check. The smut spore cannot support much of a growth of the promycelium, it is thought not over about one-hundredth of an inch. It would then be necessary for the spores to be almost in actual contact with the seed in order to send its growth into the berry. All that is necessary, then, is to destroy the spores upon the seed before it is sown. It can be readily seen that spores which might have remained in the ground over winter would not be liable to be situated near enough to the seed to cause much damage, even if we were certain that none of them had germinated in the fall.

There are two treatments recommended, the efficiency of which has been verified many times, for the prevention of smut. The hot water treatment consists in

immersing the grain in water whose temperature has been raised to 130° or 135° F. The temperature should never fall below or raise above these limits. Because, if it falls below, the spores will not be destroyed, while the seed is liable to injury if it raises above. The seed should remain in the water for ten or fifteen minutes. In order to perform this experiment successfully it is essential to have two vessels of water, one at about 120° and the other at the required temperature to kill the spores. The object of the first vessel being to raise the temperature of the seed so that the temperature of the water in the second vessel may not be lowered below 130°.

The potassium sulphide treatment consists in soaking the seed in a solution consisting of 1 lb. of potassium sulphide dissolved in 24 gals. of water. The seed should be soaked in this solution about 24 hours, partially dried, and sown.

A third treatment which is often recommended and probably more universally used than either of the above, consists in substituting copper sulphate for the salt used in the last experiment. This, however, requires a much more concentrated solution. There

is some objection to this treatment because it is liable to injure the seed.

In all of these experiments, instead of waiting for the seed to dry before it is sown, lime may be mixed with it. This serves a double purpose. It has a tendency to destroy the smut spores if any remain and also it is a good fertilixer. Any one of these experiments properly conducted will effectually destroy the smut of grain and grasses.

-- oOo --

HYPHOMYCETES. (Leaf spots.)

This order is a conglomeration of very poorly arranged, imperfect forms. They comprise some very destructive fungi, a great many species of which prey upon forage plants. They are in general very simple plants, consisting principally of erect spore bearing hyphae from the surfaces of the leaves of higher plants. These hyphae penetrate the tissues of the host for a greater or less distance and withdraw their nourishment from them in much the same manner as the Blights and Mildews. The extraction of so much nourishment from the leaf soon causes it to die in spots,

hence the name of Spot Fungi. Occasionally these spots have very peculiar appearances. The first that is noticed of the fungus is a slight purplish spot on the leaf. This enlarges in all directions leaving finally a dry scarious center with a purplish border. The life history of the majority of them is not understood.

Remedies.

The same remedies can be recommended for these fungi as for the Mildews.

-- oOo --

P A R T I I

TRIFOLIUM PRATENSE, L.

Red Clover; Common Clover.

Distribution.

Introduced from Europe in early days. It is now extensively cultivated throughout the United States. Very sparingly cultivated in South Dakota. It is not a success as far north as Brookings, because it does not stand the winters well. In the extreme south eastern part of the state, however, it is grown quite successfully.

Habitat.

It grows well in almost any soil with proper climatic conditions, plenty of heat and moisture. The roots which penetrate to a great depth prepare the soil for succeeding crops. It thrives best in a soil of clay loam, rich in lime.

Value as Forage.

Where it can be grown successfully it is one of the best of forage and pasture plants. It is generally sown with Orchard Grass or Timothy, both for pastures and hay. No chemical analysis of this species is

at hand.

Fungous Parasites.

I. *Uromyces trifolii*, (Hedw.) Lev. (Clover Rust.)

Very common on this host when cultivated at this station but it has never yet been very injurious. Only the uredo stage was found the past season.

Uredosori hypophyllous, scattered, rounded, dark-brown. Spores round to ovate, echinulate, 18-20 x 23-26 mm.

-- oOo --

TRIFOLIUM MEDIUM, L.

Mammoth Clover.

Distribution.

This species of clover is not as extensive in its distribution as *T. pratense*. It is quite extensively cultivated throughout the northern United States, as far west as Minnesota and often as far south as Mississippi. In South Dakota it is not quite as hardy as *T. pratense*.

Habitat.

The same as *T. pratense*.

Value as Forage.

In some respects this is more valuable than the

other species in the localities in which it is grown. It has a larger growth and matures later. This makes it a better plant to mix with Timothy. Southward, however, where rains are more abundant and the soil is more fertile it early becomes decumbent and by flowering time loses its lower leaves from decay, and often the lower part of the stem becomes injured also.

Fungous Parasites.

I. *Uromyces Trifolii*, (Hedw.) Lev. See *U. trifolii* under *Trifolium pratense*.

-- oOo --

TRIFOLIUM INCARNATUM, L.

Scarlet Clover; French Clover.

Distribution.

A native of Europe which has been introduced, to a limited extent, into this country.

Habitat.

The same as *T. pratense*.

Value as Forage.

It has not met with much favor where it has been tried. Being only an annual at best, it will probably

never be able to cope with the ranker growing perennials of this genus. A fair stand of it was grown at this Station last year, but it winter killed.

Fungous Parasites.

I. *Uromyces trifolii*, (Hedw.) Lev. See description of this species under *T. pratense*.

-- oOo --

TRIFOLIUM REPENS, L.

White Dutch Clover; White Clover.

Distribution.

Introduced everywhere and supposed to be indigenous in some of the New England and Central States. Very promising for South Dakota. It is now extensively cultivated in all of the eastern portions of the state.

Habitat.

It prospers well in soil rich in humus, but thrives better than red clover in poor soil. Its creeping habit renders it quite stable when once established.

Value as Forage.

This clover is practically of no value for hay,

but it is excellent for pasturage. It furnishes feed until late in the season. In South Dakota it has been extensively introduced and promises to become of considerable utility in the future. Its composition is as follows:

Fat,	4.38
Ash,	10.29
Crude fiber,	26.53
Albuminoid Nitrogen, . .	18.76
Nitrogen - free extract,	40.04
Nutritive ratio,	94.24.

Fungous Parasites.

I. *Polythrincium trifolii*, Kunze. This fungus is very common here but has not, as yet, done any serious injury.

Hyphae, hyprogenous, torulous, short, dark to smoky or olivaceous, forming irregularly-shaped, black spots on the leaves. Conidia, obovate, uniseptate, nonconstricted, olivaceous 16-22x9-12mm. This differs in spore characteristics from the ordinary description in Saccardo's "Syloge Fungorum." He gives conidia 20-24mm in length with a constriction. Pl. III.

TRIFOLIUM HYBRIDUM, L.

Hybrid Clover;Alsike Clover.

Distribution.

This is a native of northern Europe and is being extensively introduced into southern Europe and America. It is now extensively grown throughout the northern United States and eastern Canada.

Habitat.

It is best adapted to cool, damp, meadows, and a calcareous soil.

Value as Forage.

Having a much more productive growth than *T. repens* it will, without a doubt, meet with greater favor than that species, although it is not quite as hardy in rigorous climates. It is commonly reported as not enduring drouth as well as *T. pratense*, but in this climate it appears to thrive much better than that species. As it does not reach full maturity for two or three years, it is generally sown with some of the earlier developing grasses when cut for hay.

Fungous Parasites.

I. *Uromyces trifolii*, (Hedw.) Lev. See description under *T. pratense*.

MEDICAGO SATIVA, L.

Alfalfa, Lucerne, Spanish trefoil,
French clover, Brazilian clover,
Chilian clover.

Distribution.

Alfalfa has been known in cultivation from very ancient times. It is known to have been introduced into Greece from western Asia about 500 B.C. It is now extensively cultivated in Europe and America. It is well adapted to South Dakota, and bids fair to become a very valuable forage plant.

Habitat.

Although it is best adapted to a mild climate, it appears to thrive in South Dakota, and stands the severe winters very well. No case of its having winter killed is known.

Value as Forage.

Years of cultivation and its great popularity at present speak sufficiently of its value as a forage plant. It has not, however, been very favorably received in South Dakota. This is probably due to its fungous pests, and the fact that it grows very fibrous if not cut in proper season. The analysis of European

specimens by Diedrich and König show the following composition in the dry state:

Fat,	8.79
Ash,	11.41
Crude fiber,	23.03
Albuminoid nitrogen, . . .	23.25
Nitrogen - free extract, .	28.52
Nutritive ratio,	99.62.

Fungous Parasites.

I. *Pseudopeziza medicaginis*, (Lib.) Sacc. An exceedingly destructive fungus. During the past two years Alfalfa has been rendered practically worthless by it. Last year when the Alfalfa was ready to cut for hay, all but the upper leaves had fallen off, and even they were badly injured.

It first makes its appearance as minute brownish spots which finally reach a dimension of not over one-eighth of an inch. A careful examination of these spots about the time the leaves are ready to fall off will show minute round projections caused by the development of the sporocarp beneath the epidermis. The epidermis is soon ruptured at this point leaving the cell-like sporocarp exposed and projecting a slight distance beyond the surface of the leaf.

Asci stipitate, elongated, slightly narrowed

above and below, eight-spored; apex rounded 70-87x 10mm. Spores ovate, hyaline, gutulate. Paraphyses as long as the asci, filiform, multigutulate. Plate VI.

II. *Macrosporium commune*, Rabh. This fungus is not at all injurious to alfalfa as it occurs only on the decaying plants.

Hyphae, brown to olivaceous, aggregated, dense, branched, septate, presenting a dark smoky appearance to the naked eye; conidia variable, clavate to oval and oblong, both longitudinally and transversly 2-3-many septate, constricted at the principal septae, often with long pedicels which I am inclined to believe is the result of germination; 28-75x10-18mm. This fungus was obtained from specimens kept for sometime in a moist chamber. Plates IV and V.

-- oOo --

LESPEDEZA STRIATA.

Japan Clover.

Distribution.

Introduced into the southern states about 1850, since when it has spread over each of the Gulf states and northward as far as Kentucky and Virginia. Cul-

tivated, to a limited extent, northward. It is of no value for South Dakota because it cannot endure the winters.

Habitat.

Very common southward in waste places, uncultivated fields, roadsides, etc., on both high and low ground.

Value as Forage.

All stock are reported to be very fond of it, and growing as it does on poor and rich soil it has become a very important forage crop in many of the dry southern states. It bears pasturing well, and springs up almost immediately after being cut. The climate here, however, will undoubtedly prove too severe for it. It has the following chemical composition:

Fat,	4.40
Ash,	4.33
Crude fiber,	23.77
Albuminoids,	15.11
Nitrogen - free extract, .	52.39
Nutritive ratio,	61.42.

Fungous Parasites.

I. *Erysiphe communis*, (Wallr.) Tr. Very common in the grass plat here late in the fall, but the mycelium was so scanty as to be scarcely visible. The

perethesia are are very young and I therefore can give no very definite description of them.

-- oOo --

PISUM SATIVUM, L.

Common Pea.

Distribution.

Introduced from Europe and cultivated everywhere. Not very much used as cattle and hog feed in Dakota yet.

Value as Forage.

It is extensively cultivated, for hog feed, in the Central states, where it is highly esteemed as a fattening ration. Both the straw and the seed are eaten. When grown with oats or other small grain it is relished by cattle. The chemical composition of the straw of a certain variety of Pea grown in England, according to Diedrich and König in "Zusammensetzung und Verdaulichkeit der Futtermittel," is as follows:

	<u>Old.</u>	<u>Younger.</u>
Fat,	2.15	1.93
Ash,	6.23	5.34
Crude fiber,	53.84	41.07.
Albuminoid nitrogen, . . .	7.71	7.93
Nitrogen-free extract, . .	30.07	43.73
Nutritive ratio, (old straw)	52.85	
" " (younger ")		67.63

Fungous Parasites.

I. *Erysiphe communis*, (Wallr.) Fr. Very common here late in the fall, considerably injuring the quality of the straw and undoubtedly diminishing the yield of seed.

Amphigenous. Mycelium persistent and abundant; perithecia with hyaline appendages of no definite length, resembling the mycelium. Asci 4-8 with thick intrigument. Sporidia, hyaline, granular, 5 to the ascus in my specimens, oval to oblong. Plate VII.

-- oOo--

BETA VULGARIS, L.

Beet.

Distribution.

Extensively cultivated throughout the United States, especially northward. Introduced from Europe. It promises to become of great value in South Dakota for its sugar as well as for forage purposes.

Habitat.

The numerous varieties of this species thrive in deep, rich soil which has been well fertilized.

Value as Forage.

The numerous varieties of *Beta vulgaris* are without a doubt the most productive of any of our Dakota root crops. They are relished, by cattle, horses, sheep and hogs, both raw and cooked. Repeated experiments have proven beyond a doubt that beets thrive well here. They are easily stored and can be fed throughout the winter and until late in the summer.

Fungous Parasites.

I. *Cercospora beticola*, Sacc. This fungus has not been very destructive thus far, but it is becoming quite plentiful on all varieties of beets. It produces scarious, dead, purple margined spots upon the leaves. In the center of these spots small dark tufts of hyphae can be seen with an ordinary lens.

Hyphae, cylindrical, short, 40-50x4-5mm, with nodulous apices; olivaceous. Conidia, obclavate, many septate, hyaline, 15-7x3mm. Plate VIII.

-- oOo --

POLYGONUM ERECTUM, L.

Knotweed.

Distribution.

From Nevada and Oregon eastward and southeastward to the Atlantic. Common throughout South Dakota.

Habitat.

Common everywhere in yards, waste places, roadsides, etc.

Value as Forage.

Until lately, this plant has been looked upon as a worthless weed, but all cattle-men praise it highly. It has often been noticed that cattle are very fond of it. It is doubtful, however, whether it will ever become of much value as a forage plant, owing to its habit of growth.

Fungous Parasites.

I. *Uromyces polygoni*, (Pers.) Fckl. Very common on this host. It has been collected during the past season at Brookings, Sand Lake and Gettysburg.

Uredo-and teleutosori amphigenous, yellowish to brown, small, the latter more prominent.

Uredospores subglobose with minutely echinulate, thick episporous, 17-18x22-24mm.

Teleutospores oval to oblong, or obovate, rounded and thickened at the apex, smooth, 17-20x23-29mm.

Pedicel long and hyaline. Plate IX.

II. *Cercospora avicularis*, Wint. This fungus does considerable injury, appearing as small purplish spots which soon extend in diameter leaving a brown dead center with purplish margin. With a strong hand glass the hyphae may be seen in these dead centers.

Hyphae, dark brown, short, slightly torulose, erect, in small, dense tufts. Conidia elongate, obclavate and broadly linear, septate, 24-52x3 1/4-4mm Plate X.

-- oOo --

POLYGONIUM AVICULARE, L.

Knotweed.

Distribution.

Same as *P. erectum*.

Habitat.

Same as that of *P. erectum*.

Vaule as Forage.

This is eaten and relished by cattle as well as *P. erectum*, but owing to its dwarfed and decumbent growth it is not as promising as that species.

Fungous Parasites.

I. *Uromyces polygoni*, (Pers.) Fekl. See description

under *P. erectum*.

II. *Cercospora avicularis*, Wint. See description under *P. erectum*.

-- oOo --

JUNCUS TENUIS, WILD.

Rush, Bog Rush.

Distribution.

New England westward across the continent, and northward to Saskatchewan. Very common throughout South Dakota.

Habitat.

Grows in low, moist places, in ravines and along river bottoms; also quite common in high waste places that are being sodded over.

Value as Forage.

Not of much account as it seldom grows in sufficient quantities to be of any use. It is sometimes eaten by cattle to a limited extent in pastures. No chemical analyses have been made of it.

Fungous Parasites.

I. *Uromyces junci*, (Schum.) Tul. Teliosori black, amphigenous, scattered, sometimes confluent, round or

oval.

The uredospores are not present in these specimens. Teleutospores clavate to roughly elliptical, smooth; apex, obtusely pointed, rounded, or nearly truncate, strongly thickened, dark brown; base narrowed to the pedicel; 14-20x24-40mm. Pedicel tinted, about the length of the spore. Plate XI.

-- oOo --

ELEOCHARIS PALUSTRIS, R.BR.

Rush.

Distribution.

Very common all over the United States and in the greater portion of Europe and Asia. It occurs in great quantities in South Dakota, especially in the northwestern part of the state where there are acres of ground covered with it alone.

Habitat.

It appears commonly in water, when it is stout and tall; or in moist, grassy grounds, when it becomes short and very much tufted.

Value as Forage.

Not of much value. It is sometimes eaten by

cattle in pastures, but is never cut for hay. I have not been able to find an analysis of it.

Fungous Parasites.

I. *Claviceps nigricans* (?) Tul. Appears to have been quite common throughout the state the past season. It was collected by Prof. Williams in great abundance at Huron; a few specimens were found by Griffiths and Schlosser at Bangor, and by Thornber at Sioux Falls.

Sclerotia semicylindrical, flattened on the inside, curved, black on the outside, white within; totally devoid of any purple coloring; about 5x1mm.

This may be the European *C. nigricans*, Tul., although never before reported from North America. Of course nothing can be certain without cultivation, but the characteristics of the sclerotia certainly point toward *C. nigricans*.

-- oOo --

SCIRPUS FLUVIATILIS, GRAY.

River Club-Rush.

Distribution.

Common in the northern states from the Atlantic to the Rocky Mountains. Common in all parts of the state.

Habitat.

Borders of lakes and streams and in low, wet ground.

Value as Forage.

Often extensively cut for hay and pastured along lakes and river courses. When cut young it makes very good hay. In South Dakota it is an important winter feed, especially in the Jim river valley. I know of no analysis.

Fungous Parasites.

I. *Uromyces scirpi*, Burrill. Common, and very injurious late in the fall.

Sori amphigenous, brown, long, covered by the epidermis, scattered and often confluent in long lines. Uredospores, brown, echinulate, irregularly elliptical, 16-20x28-34mm. Teleutospores, clavate elliptical, widest at the center; apex pointed or rounded, thickened and darkened, but becoming lighter toward the point, 16-22x32-44mm. Plate XII.

-- oOo --

SCIRPUS LACUSTRIS, L.

Great Bulrush.

Distribution.

Common throughout the United States. Found also in Europe and Asia. Common throughout the state.

Habitat.

Grows in very wet ground and in shallow, fresh water, and in the edges of streams, ponds and lakes.

Value as Forage.

It has no agricultural value. Sometimes, however, it is eaten by cattle when other pasture feed gives out.

Fungous Parasites.

I. *Puccinia obtecta*. Pk. Of frequent occurrence in this state, but has never been seen sufficiently abundant to do any particular damage to the host.

Uredo- and teleutosori amphigeneous, irregularly scattered, subcircular to oval, often aggregated, and sometimes confluent; very prominent in brown or black elevations, which are long covered by the epidermis. Even when the spores become exposed the epidermal covering does not disappear, but simply opens in a narrow line lengthwise of the sorus.

Uredospores elliptical or oblong with thick echinulate episporae; 15-20x26-32mm.

Teleutospores elliptical, constricted, and narrow-

ed into the pedicel; apex variously produced and pointed; 16-24x44-60mm; mixed with uredospores, not numerous. Plate XIII.

-- oOo --

SCIRPUS PUNGENS, VAHL.

Distribution.

Throughout the whole of North America; also found in Europe and South America. Common in South Dakota east of the Missouri river.

Habitat.

On the borders of salt and fresh ponds and streams and in low wet meadows.

Value as Forage.

Sometimes pastured to a slight extent, but never unless other sedges and grasses are very scanty. I know of no chemical analysis that has ever been made of it.

Fungous Parasites.

I. *Puccinia obtecta*, Peck. Reported only from ^{Huron} by T. A. Williams. In the specimens collected by him only the uredospores are present. It does not appear to be very injurious.

Uredospores, echinulate ovate to obovate-oblong, 23-29x15-20mm. See description of this species under *S. lacustris*.

-- oOo --

CAREX FILIFOLIA, NUTT.

(*Uncinia breviseta*, Torr.)

Distribution.

Reported by Coulter as occurring from Colorado westward; but it is known to occur as far eastward in South Dakota as the James river, being especially abundant in the Missouri river counties.

Habitat.

It grows on dry plains and mountains. In South Dakota is often forms the principal sod on the tops of small knolls in and about the ranges of Coteaus in the western part of the State.

Value as Forage.

This sedge is seldom if ever eaten by the range cattle. It is not only of no particular value for grazing or forage purposes, but it is very detrimental to the breaking up of the soil, on account of its immense root growth. No chemical analyses have ever

been made.

Fungous Parasites.

I. *Puccinea caricis*, (Schum.) Rebert. This was very common during the year 1892 in the western part of the state. At LeBeau especially, it was very injurious.

Teleutosori hypogenous, small, oval, often confluent, and scattered on leaf and culm. Spores cuneate, slightly constricted, with strongly thickened, truncate to rounded, and often pointed apices, 16-22x32-40mm. Pedicels one half the length of the spores or longer.

II. *Leptosphaeria* sp. This was found in a very limited quantity in some of the host which was collected for *Puccinia*.

-- oOe --

Carex sp.

Fungous Parasites.

I. *Puccinia caricis*, (Schum.) Rebert. A common and injurious rust. Collected several times in and about Brookings the past season.

Sori black, elongated, often confluent, prominent,

long surrounded by the ruptured, ragged edges of the epidermis. Uredospores mixed with the teleutospores, globose to slightly elongate, echinulate, with thick episporae; 18-22x16-20mm. Teleutospores differ considerably from the descriptions, being cuneate, conspicuously constricted; episporae smooth, strongly thickened at the apex and septum; apex roundly to bluntly pointed, 36-64x15-18mm. Pedicel short, nearly colorless, generally less than half the length of the spore. Plate XIV.

It will be seen that these spores are much longer than usually described, and that they are considerably more constricted. The thickening of the episporae at the constriction I have never seen mentioned. The inferior cells seem to be dwarfed and elongated. Indeed, in some instances, it would seem that the spore was one-celled with a long pedicel were it not for the partition in the lower part. Specimens in the Herbarium of the University of Nebraska, from the Herbarium of S.M.Tracey, collected at Plattsville, Wisconsin, show the same characteristics but not so conspicuously as in my specimens.

ZEA MAYS, L.

Corn.

Distribution.

A native of America, but is now extensively cultivated in all of the grand divisions. It is known to occur native only in Mexico at the present time. In the United States it is grown to the greatest extent in the Central states.

Habitat.

It thrives best in deep, black loam, rich in humus and in warm, temperate subtropical regions. Grown as it is in hills, several crops can be obtained to good advantage on the same ground, without rotation of crops.

It also grows well on sandy soil if it has been well fertilized by artificial means.

Value as Forage.

The value of this plant as food for both man and beast is too well known to need any explanation. It formed the most important article of diet of the North American Indians before their discovery by the Europeans and, since that time, the amount of it grown has increased with the increase of population. New uses

are continually being found for it. It is grown for the fodder as well as for the grain.

Fungous Parasites.

I. *Ustilago maydis*, (D.C.) Corda. This, the ordinary corn smut, is always more or less destructive to corn wherever grown. It attacks the ears and tassles, and often appears on the stems and leaves, forming a black powdery mass which consists of myriads of teleutospores. These, when examined under a high power, are pale brown, subglobose, finely echinulate, and 7 to 12mm in diameter. Plate XV.

II. *Puccinia maydis*, Carradoii. Very common on corn in this vicinity.

Sori amphigenous, subcircular to oblong, often confluent, surrounded by the lacerated remains of the epidermis. Uredospores subglobose; epispore thick, echinulate, 24-29mm. Teleutospores broadly elliptical, constricted, rounded at both ends, seldom pointed, slightly thickened at the apex, 18-22x29-35mm. Pedicels about twice the length of the spore, nearly colorless. Plate XV.

ANDROPOGON SCOPARIUS, MICHX.

Little Blue Stem, Indian Grass, Purple
wood-grass, Wire - grass.

Distribution.

Northern United States westward to the Rocky Mountains and southward to Texas and Mexico, in the mountains. Common throughout South Dakota.

Habitat.

It is found most commonly in dry ground. In the western part of the state and along the Missouri river it is the principal grass along the sidehills.

Value as Forage.

When this grass grows on comparatively rich soil which has sufficient rain fall, it makes good hay, if cut while young. But where it thrives best, there is but little rain fall and the stems of the grass become very fibrous long before maturity. [It is readily eaten by cattle early in the season, but a little later it may be seen standing in tufts upon the range, untouched, while the other, more succulent grasses are eaten close to the ground.

Fungous Parasites.

I. *Puccinia andropogi*, Schw. See description

of this species under *A. provincialis*.

-- oOo --

ANDROPOGON PROVINCIALIS, LAM.
(*A. furcatus*, Michx.)

Big Blue-stem.

Distribution.

Common from Colorado to Texas, and is also an important grass in the Atlantic States. Distributed throughout the state.

Habitat.

Grows in dry and sterile soil, according to the manuals, but in South Dakota I have noticed that it grows most commonly in shallow soil with a subsoil of clay, along the edges of river bottoms and flats.

Value as Forage.

One of the important forage grasses of the western prairies states. It is eagerly sought after by cattle whenever it occurs in pastures. It is extensively cut for winter feed. Its chemical composition according to Dr. O'Brine of the Colorado Experiment Station, Bulletin No. 12, July 1890, is as follows:

Moisture, 8.71

Fat,	2.06
Ash,	4.51
Crude fiber,	21.66
Albuminoid Nitrogen,	3.80
Nitrogen-free extract,	67.97
Nutritive ratio,	80.92.

Fungous Parasites.

I. *Puccinea andropogi*, Schw. Has been found quite common upon this grass in the vicinity of Brookings, S. D. the past season. Although the rust has frequently been found in various parts of the state it has never been found seriously injuring the host excepting in a single instance. In a little clearing in the center of a large cotton-wood grove about ten miles above Forest City, I found about half an acre of this grass very badly affected. This special locality and circumstance seemed to favor its growth, for outside of the timber there was an abundance of grass which was but very little, if at all, affected.

Sori hypophyllous, small, oval, often confluent in long lines, and surrounded by the lacerated remains of the epidermis. In all the material examined, I have seen but two uredospores. These were subglobose tuberculate, 20 and 21mm in diameter. Teleutospores obovate to elliptical, constricted at the septum. Apex

rounded, sometimes obtusely pointed and strongly thickened. Epispore smooth, dark brown, 15-20x 30-44mm. Pedicel from slightly longer to considerably exceeding the length of the spore; tinted. Plate XVI.

II. *Sorosporium Ellisii* (?) Wint. (*Ustilago andropogonis*, K & S.) Not a very common fungus, but where it is found it generally infests all of the host plants in the immediate vicinity.

Spores variable, subglobose to polyhedral; epispore rather thin, rugose, 9-18x14-21, light brown. Plate XVI.

III. *Cladosporium graminum*, Corda. Not injurious. Found only in wormy heads. This, together with the *Macrosporium hyphae*, cause the whole head to look black and smutty.

-- oOo --

SORGHUM HALAPENSE, PERS.
(*Andropogon sorghum*, Brot.,
var *halapensis*, Hack.)

Johnson Grass, Cuba-grass, StMary's-
grass, False Guinea-grass, Mean's-
grass, Guinea-grass.

Distribution.

A native of northern Africa which was introduced

into Alabama in 1840. Extensively used in the Southern states, and somewhat in the northern.

Habitat.

A dry-land perennial grass which needs cultivation every third or fourth year to be successfully grown. Its underground stems assist it in establishing itself firmly when once introduced and have rendered it a vile weed in many places.

Value as Forage.

Its chief value is for hay. It is too tender for this state as it winter-kills as far south as Alabama. In some of the southern states it is considered a vile weed. Its composition in Alabama is:

Fat,	2.86
Ash,	4.85
Crude fiber,	25.15
Albuminoid Nitrogen,	13.18
Nitrogen-free extract,	53.96
Nutritive ratio,	89.66.

Fungous Parasites.

I. *Cercospora sorghi*, E. & E. A very destructive fungus. It causes large, purple margined blotches and streaks on the leaves. The colored part soon becomes dead and dry, and out of the dry part project minute, hyphae-bearing conidia.

Hyphae, amphigenous in tufts from the stomata on dead part of the leaf, simple, few in a tuft, septate, subdentate above, brown or smoky, 60-80x4-4 1/2mm. Conidia one to many septate, very variable, broadly ovate to oblong, concolorous, 4-12x12-60mm.

Plate XVII.

-- oOo --

PANICUM CRUS-GALLI, L.
 Barn-grass, Barnyard Grass, Cock's
foot, Water-grass, Large Crow-foot-grass.

Distribution.

Supposed to be introduced from Europe. Abundant across the continent, and probably indigenous in some of its forms.

Habitat.

Grows abundantly in low moist and especially in well manured grounds about barn-yards. It often grows in cultivated fields and along the edges of ponds.

Value as Forage.

A grass of which horses and cattle are very fond in either the green or dry state. In the northern states it is seldom used but, on the other hand, it is

considered a troublesome weed. It is especially injurious to shallow rooted crops. But in the southern states, particularly Mississippi, it is extensively cut year after year without re-sowing. Its analysis shows:

Fat,	2.15
Ash,	6.98
Crude fiber,	28.91
Albuminoids,	7.77
Nitrogen-free extract, . . .	54.19
Nutritive ratio, 77.19.	

Fungous Parasites.

I. *Ustilago* sp. This is not a common species of smut in this locality but when found it is very plentiful, generally in small areas. I have always found it on plants growing in heaps of rubbish and in abandoned road-beds. The past season there were two localities around Brookings that were very badly affected,- one in an old rubbish heap, and another in a neglected road-bed.

When a plant is at all effected, usually every panicle is completely ruined. It often appears, also, on the nodes, where the black masses of spores are exposed much sooner than when they occur in the panicle. The mass of spores is for a long time enclosed

in a leathery, pubescent membrane. Spores globose, verrucose, light brown, 8 to 12mm in diameter.

It will be seen by the description that this varies considerably from *U. sphaerogena*. The spores are larger, and the nature of attack is very different. The only specimen of smut on this host in the Herbarium of the University of Nebraska is *U. sphaerogena*, from Ellis & Everhart, in which the fungus is found in the ovaries alone.

II. *Cladosporium graminum*, Corda. Rare, not injurious. It causes brown-margined spots and streaks on the leaves. For description of the fungus look under *Homaloc-enchrus osyzoides*.

-- oOo --

PANICUM CAPILLARE,

Old Witch-grass. Tool's hay.

Distribution.

Found everywhere across the continent.

Habitat.

Sandy soil and cultivated ground.

Value as Forage.

Its chemical analysis as given by O'Brien of the

Experiment Station of Colorado, shows up well; but its habits of growing in cultivated soil and never making a heavy crop render it of no particular value. In Nebraska, however, it furnishes considerable fall feed as it comes up plentifully in stubble fields. Its weed habits more than counterbalance its value as shown by its high nutritive ratio.

Moisture,	8.50
Fat,	2.78
Ash,	9.70
Crude fiber,	18.71
Albuminoid nitrogen,	12.34
Nitrogen-free extract,	56.47
Nutritive ratio,	91.97.

Fungous Parasites.

I. *Sorosporium syntherismae*, (Schw.) Farl. This fungus is very destructive. It is not uncommon to find a large plant with eight or ten panicles completely destroyed by the fungus.

Spores rotundo-polyhedral, minutely roughened; epispore thick, brown, 8 to 12mm in diameter.

II. *Puccinia emaculata*, Schw. I have never examined Dakota specimens of this rust. Although it was collected here in large quantities last year. The specimens were all mislaid.

PANICUM CLANDESTINUM, L.

Distribution.

From New England to Dakota and southward. Very common in South Dakota often appearing in fields which have remained uncultivated for three or four years.

Habitat.

Low thickets, riverbanks, roadsides, and waste-places.

Value as Forage.

Practically of no value as a hay grass, but is sometimes eaten to a limited extent in pastures. I know of no analyses that have ever been made of it.

Fungous Parasites.

I. *Cercospora* sp. This fungus does considerable injury, causing brown, scarious, oval spots and streaks upon the leaves.

Hyphae amphigenous, erect in dense clusters from the stomata, nodulose above, olivaceous with hyaline tips, non septate, 3-4x28-40mm. Conidia, hyaline, subattenuate, 3-many septate, generally curved, 30-60x2 1/2-3mm.

This does not correspond with any description

with which I am acquainted. It cannot be *C. fusimaculans*, Atk., because it differs too much in measurements of both conidia and hyphae, also in the number of the spetae. Plate XVIII.

II. *Epichloe* sp. This is a rare and peculiar fungus, appearing on the culm in a black cylindrical mass which completely surrounds it. It has been collected here but once, and then only in very limited quantity in the conidial stage. In habit it closely resembles *E. typhina*, the only recorded American species. It differs from this, however, in habitat in as much as it appears on the culm of the grass instead of the sheath. It may prove to be an entirely new species.

Stroma, black, surrounding the culms of the living grass, extending longitudinally 2-6 centimeters, and bearing linear, hyaline, 8-12x $3/4$ -1mm, conidia. Plate XIX.

This fungus is appearing to a very limited extent again this year.

PANICUM DEPAUPERATUM, MUHL.

Distribution.

Common with *P. clandestinum* across the continent.

Habitat.

Growing principally on dry and high prairies, generally on slopes of slight elevations. It is very common at times in South Dakota where the sod has been broken and then allowed to run back.

Value as Forage.

Cattle are very fond of it, but it is seldom found in large enough quantities to be of much value. It is never large enough to be cut for hay. No recorded analyses of have been made.

Fungous Parasites.

I. *Cercospora* sp. See *P. clandestinum*.

-- oOo --

PANICUM VIRGATUM, L.

Switch-grass, Wild Red-top,
Black Bent.

Distribution.

Common on the eastern sea coast of the United

states, and from there to the Rocky Mountains.

Habitat.

It grows best in low, sandy, soil where it appears in bunches. It, however, grows very well even in dry sandy land. Along the Missouri River in South Dakota, it grows very luxuriantly.

Value as Forage.

It makes very good hay when cut young, but if left until it gets old it becomes of but little value. It is one of the principal grasses of the Missouri River bottoms. Its analysis shows:

Fat,	3.33
Ash,	5.49
Crude fiber,	29.11
Albuminoids,	5.12
Nitrogen-free extract,	56.95
Nutritive ratio,	75.30.

Fungous Parasites.

I. *Puccinia emaculata*, Schw. Common in this vicinity upon this host in both the native and cultivated forms. It has never been noticed sufficiently abundant, however, to do much damage to the native form, but that cultivated in the forage plats last year was nearly ruined by this rust.

Uredo- and teleutosori mostly epigenous and

crowded upon the leaves, black as soon as the epidermis is ruptured. Uredospores subglobose; epispore thin sharply echinulate. The germ spores are very prominent, 21-24mm in diameter. Teleutospores broadly clavate to elliptical, apex rounded, or obtusely pointed and thickened; slightly constricted, 16-21x31-35mm. Pedicel exceeding the spore, slightly tinted.

II. *Uromyces graminicola*, Burrill. Very rare. Teleutosori hypogenous in my specimens, very prominently surrounded by the lacerated remains of the ruptured epidermis. Teleutospores variable, subglobose to oval and oblong, smooth; apex mostly rounded, but also bluntly pointed and often truncate, thickened, 14-18x20-30mm. Pedicel stout, slightly tinted, about twice the length of the spore. Plate XX.

-- oOo --

SETARIA VIRIDIS, BEAUV.

Green Fox-tail, Pigeon-grass, Green
Pigeon-grass, Bottle-grass,
Wild Millet.

Distribution.

Common everywhere.

Habitat.

It is generally introduced into cultivated grounds where it becomes a great pest, propagating itself year after year from the seed.

Value as Forage.

This grass is recorded as being fully as nutritive as Hungarian grass, but it is not as productive and is seldom used for hay. Its composition is:

Moisture,	8.00
Fat,	2.87
Ash,	12.15
Crude fiber,	16.40
Albumenoid nitrogen,	8.67
Nitrogen-free extract,	59.19
Nutritive ratio,	86.64.

Fungous Parasites.

I. *Sclerospora graminicola*, (Sacc.) Schroet.
 Very destructive, often causing the leaves to wither and turn brown before the grass heads out. Conidial stage appears as a white mildew on the under side of the leaf, near the base; while oospores are produced on the enlarged glumes or on the outside of the unopened sheath and blade.

Hyphae hyaline, branched 15-18x30-140mmn, bearing granular, hyaline, elliptical, 9-13x14-22mmn

conidia. Exospore, brown, with a light brown center, irregularly subglobose, 40-52mm in diameter. When pressed the thick episporied globular, 30-32mm, endospore escapes. Plate XXI.

-- oOo --

SETARIA ITALICA.

Italian Millet, Bengal grass.

Distribution.

Introduced and extensively cultivated in the United States. It forms one of the most important hay grasses in South Dakota.

Habitat.

Cultivated. It is a very good crop to plant after the land has been run out by other crops. If properly handled one crop of millet will clear the land of weeds.

Value as Forage.

There are many objections made to this grass for horses, but it makes excellent feed for cattle. It grows very luxuriant, often cutting three tons of dry hay per acre. Its chemical analysis shows the following composition:

Fat,	2.71
Ash,	7.50
Crude fiber,	24.52
Albuminoids,	9.49
Nitrogen-free extract,	55.78
Nutritive ratio,	83.98

Fungous Parasites.

I. *Sclerospora graminicola*, (Sacc.) Schroet.

Not very common on this species of *Setaria*. See description under *S. viridis*.

-- oOo --

CENCHRUS TRIBULOIDES, L.

Sand bur, Sand spur, Hedge hog grass,
Burr grass, Cock spur grass.

Distribution.

Found in localities across the continent and southward into Mexico.

Habitat.

Thus far it has been found only along the Missouri River in South Dakota. It is very common on the eastern sea coast, the coast of the Great Lakes, and sandy river banks. It is usually most common in sandy soils. It cannot thrive well in rich soil.

Value as Forage.

This is one of the greatest pests of sandy soils,

where it is a menace to man and beast. It is very injurious to the wool of sheep that graze near it, and is of no agricultural value. Its nutritive ratio is high, but the burrs make it impossible for cattle or horses to eat it. Its analysis shows:

Fat,	3.60
Ash,	9.24
Crude fiber,	14.14
Albuminoid nitrogen,	10.53
Nitrogen-free extract,	60.49
Nutritive ratio,	92.84.

I. *Sorosporium syntherismae*, (S.) Farl.

(*Ustilago cesatii*, Fisch.) This fungus was collected in Union County by Wallace, the only place in which it was seen this year.

Spores rotundo-polyhedral, roughened to tuberculate, epispore, thick, 8-11x8 1/2-14mm, brown.

Plate XXVII, Fig. 8-11.

-- oOo --

ZIZANIA AQUATICA, L.

Indian Rice, Wild Rice, Water Rice,
Water Oats, Tuscasora Rice.

Distribution.

Found in nearly all portions of temperate and

tropical North America; also in eastern Siberia and Japan. Common throughout South Dakota.

Habitat.

It grows only in the neighborhood of lakes, ponds and water courses, generally growing directly from the water. Sometimes it covers large areas of shallow lakes, where the water is three or more feet deep.

Value as Forage.

Cattle are reported to be very fond of this grass and its grain is undoubtedly very nutritive, but it is very doubtful whether it will ever become of any agricultural value because it appears to thrive only on very wet land. I know of no analysis of the plant.

Fungous Parasites.

I. *Cladosporium graminium*, Corda. Not destructive. See description under *Homalocenchrus oryzoides*.

II. *Entyloma crastophilum*, Sacc. (*Ustilago lineata*, Cooke). This fungus does considerable damage in the fall, causing elongated, dark spots under the epidermis of the leaves and sheathes, and black, shining ones under the epidermis of the culm.

Sori, oblong to linear on the leaves and sheathes,

often confluent, grayish black; on the culms, oval to oblong, and often entirely encircling it, shining black, long covered by the epidermis. Spores sub-globose to oblong, angular; epispore thick, smooth, light brown; center hyaline, 7-10x8-12mmn. Plate XXII.

-- oOo --

HOMALOCENCHRUS ORYZOIDES, (L) POLL.
(*Leersia oryzoides*, Swz.)

Rice Cut grass, Rice Grass,
Cut grass, White grass, European Cut grass,
Prickle grass.

Distribution.

Common across the continent to Colorado. Frequent along Sioux and Missouri rivers in South Dakota.

Habitat.

Grows in very wet places along banks of streams, generally in the edges of water.

Value as Forage.

Not of much value, although sometimes cut with other grasses for hay. Cattle avoid it on account of the fine hooked prickles which make cutting edges on the leaves.

Fungous Parasites.

I. *Cladosporium graminum*, Corda. This is not destructive. It appears on both sides of the semi-living leaves, causing dark, indistinct spots. The hyphae extend out of the stomata, simple, erect, nodulous, dark or smoky. Conidia concolorate, very variable, oval to oblong and obovate, one to many septate. Plate XXIII.

II. *Metasphaeria leersia*, (Pass.) Sacc. Rare. Appearing as minute black spots on the dead leaves of the host.

Perithecia spherical, depressed, light smoky-brown, thin, membranaceous. Asci straight or curved, cylindrical, sometimes attenuated, 8 spored. Sporidia, obliquely uniseriate, uniseptate, indistinct, oblong, hyaline, 4-guttate. Plate XXIV.

-- oOo -- oOo --

PHALARIS ARUNDINACEA, L.

Reed Canary grass.

Distribution.

It is very common across the continent, especially in the northern part. In the neighborhood of Sand

Lake in this state there are large tracts of low ground upon which nothing but this grass grows. Common throughout the state.

Habitat.

It grows, naturally, in low, wet places, along the banks of streams, etc. It is, however, capable of cultivation on high ground.

Value as Forage.

Probably one of the most promising grasses for the dry prairie states of the west, because it makes a luxuriant growth on dry ground. It has proven to be a very excellent grass in South Dakota, obtaining a growth on upland of two to two and one-half tons per acre. Its composition is as follows:

Moisture,	8.44
Fat,	<u>3.40</u>
Ash,	7.16
Crude fiber,	19.15
Albuminoid nitrogen, . . .	7.12
Nitrogen-free extract, . .	63.17
Nutritive ratio, 77.32.	

Fungous Parasites.

i. *Puccinia striatula*, Peck. This appears to be a rare fungus here. It has been collected but once, and then late in October, in a very limited quantity, on the native varieties.

Sori amphigenous, linear, black, deeply seated, parallel, often crowded, long covered by the unbroken epidermis. Uredospores echinulate, subglobose to obovate, 18-21x19-28mm. Teleutospores oblong, slightly tapering at the bottom; apex obtusely pointed to truncate, not constricted, 16-20x33-60mm. Pedicel very short, colored. Plate XXV.

II. *Claviceps purpurea*,[?](Fr.) Tul. Rare. Sclerotia 7x1 1/2mm or less, slightly curved, cylindrical, purplish black on the outside, white within, wrinkled.

-- oOo --

ARISTIDA BASIRAMEA, ENG.

Tripple-awned Grass.

Distribution.

Minnesota southwestward to northwestward. Very common in the western part of South Dakota, especially in the Black Hills along the Cheyenne River.

Habitat.

Dry prairie regions and foot hills of the Rocky Mountains. Western South Dakota.

Value as Forage.

Its value for forage is not very well known. The probabilities are that it is a very worthless range grass. Its analysis is as follows:

Moisture	9.16
Fat,	<u>2.29</u>
Ash,	10.09
Crude fiber,	16.28
Albuminoid nitrogen,	4.06
Nitrogen-free extract,	67.28
Nutritive ratio,81.23.

Fungous Parasites.

I. *Ustilago aristidae*, Peck. Collected by Williams and Wilcox, along the Cheyenne River near Smithville. The whole seed, although not swollen any, is full of a mass of spores, covered by a thin membrane.

Spores subglobose to angular, smooth, black, occupying the whole interior of the seed, 6-10mm. in diameter. In my specimen, large oil globules are very common. Plate XXVI.

STIPA VIRIDULA, TRIN.

Feather Bunch-grass, Bunch-grass,
Wild Oat-grass, Wild Oats,

Feather-grass.

Distribution.

Minnesota westward to California and northward into British America. In all portions of South Dakota.

Habitat.

Dry places in prairies and meadows.

Value as Forage.

It is eagerly sought for by stock, but it is not common enough in this region to be of any great benefit. Its chemical composition is as follows:

Moisture,	8.30
Fat,	2.28
Ash,	7.75
Crude fiber,	19.33
Albuminoid nitrogen, . . .	9.47
Nitrogen-free extract, . .	61.12
Nutritive ratio,	88.57.

Fungous Parasites.

I. *Ustilago hypodytes*, (Schlecht.) Fr. This is not a common species here. It has been found only in one locality, but it has been very destructive there for the past two years. It occurred on three or four joints of the culm, completely covering it and entire-

ly destroying the fruit, often preventing the panicle from appearing at all.

Spores subglobose to quadrangular, irregular, 3 to 5mm in diameter, light brown; epispore thick in proportion to the size; center light. Plate XXVI.

II. *Puccinia stipae*, Arthur. See description under *S. spartea*.

-- oOo --

STIPA ^SAPARTEA, TRIN.

Porcupine grass.

Distribution.

Illinois to Michigan and from there northward and westward. It is one of the commonest of prairie grasses throughout the eastern half of South Dakota.

Habitat.

Its natural habitat is high and dry prairie, but it is often found on low dry ground also. It is said to be very common in Colorado along irrigating ditches.

Value as Forage.

A very troublesome prairie weed. The long, bent "spears" do great damage to horses and cattle. Horses have been known to go without eating for several days

on account of the spear-like fruit which had worked into their mouths. The fruit, with the enclosing glume, very often work into the sheep's wool, and then into the flesh, causing large sores. If a tract of land which has a large amount of this grass upon it is kept pastured quite close, so that the fruit cannot develop it makes very good feed for sheep and cattle. In fact, the grass itself without the "spears" is of considerable value. Sometimes the prairie is left unmown until the "spears" fall off and twist themselves into the ground. The grass is then cut and raked up, while the awned spears are left on the ground. Its composition consists of:

Fat,	2.46
Ash,	4.78
Crude fiber,	23.81
Albuminoid nitrogen,	8.34
Nitrogen-free extract,	60.61
Nutritive ratio,	85.56

Fungous Parasites.

I. *Puccinia stipae*, Arthur. Rather rare. It has been collected but once in this neighborhood.

Uredo sori scattered, small, oblong, yellow, epiphyllous. Spores subglobose to oblong, very conspicuously roughened, yellow, 17-23x20-32mm. Teleu-

tosori, dark brown, naked, epiphyllous scattered with no encircling epidermis. Spores oblong to obovate, smooth, brown, very conspicuously constricted at the septum, 17-27x45-60mm.

II. *Ustilago hypodytes*, (Schlecht.) Fr. See description under *S. viridula*.

-- 000 --

ORYZOPSIS MICRANTHA, THURBER.

Mountain Rice.

Distribution.

From western South Dakota westward to Colorado and thence southward through the mountains. It is of frequent occurrence in South Dakota, along the Missouri River and in the Black Hills.

Habitat.

It commonly grows in sandy soil along streams. In the Missouri River region it grows almost entirely in the edge of ^{timber} along the river bottoms.

Value as Forage.

This is a worthless grass in all respects. It never grows in sufficient quantity to be of any use even if its composition was good. There, probably,

has never been an analysis made of it.

Fungous Parasites.

I. Puccinia n. sp. This appears to be a very common and destructive rust. No specimens of the host were found last year without fungus on them.

Sori black, rounded to oval, small, on culms, sheaths, and upper sides of the leaves; black, very prominent, often confluent, early erumpent; ruptured epidermis not prominent. Uredospores, subglobose, echinulate, 18-24mm in diameter. Teleutospores broadly elliptical to oblong clavate, smooth, brown, constricted, thickened at the rounded to bluntly pointed apex: center granular with nuclear spots distinguishable, 25-30x32-46mm. Pedicel long and hyaline, twice to thrice the length of the spore. Plate II, Fig. 2.

-- oOo --

MUHLENBERGIA MEXICANA, TRIN.

Drop Seed grass, Wood Grass,,
Knot-root Grass.

Distribution.

Common from Wyoming eastward. It occurs in

localities throughout the southeastern portion of South Dakota.

Habitat.

Low meadows, pastures, and waste places, and un-often in cultivated fields.

Value as Forage.

It has never been cultivated but it is a very important agricultural grass in its native state eastward. It is not plentiful enough to be of any great value in South Dakota. Its composition is:

Water,	14.30
Fat,	2.30
Ash,	3.71
Crude Fiber,	19.45
Albuminoids,	4.13
Nitrogen-free extract,	56.11.

Nutritive ratio, . . 70.31.

Fungous Parasites.

I. *Phyllachora graminis*, Pers. Rare. For description look under *Bouteloua oligostachya*.

MUHLENBERGIA GLOMERATA, TRIN.

Muhlenberg's Grass, Satin Grass.
Wild Timothy.

Distribution.

Common in the western portions of the United States, to Utah thence southward to Texas.

Habitat.

Reported to grow in low, swampy ground, but my experience is that it grows on high ground almost entirely in Dakota. It commonly makes its appearance in neglected fields.

Value as Forage.

Highly recommended and extensively utilized in the eastern portion of the United States. It is, however, rather coarse and fibrous unless cut while young. Its chemical analysis shows:

Moisture,	7.24
Fat,	<u>2.37</u>
Ash,	9.31
Crude fiber,	19.50
Nitrogen-free extract,	62.02
Albuminoid nitrogen,	6.80
Nutritive ratio,	82.97.

Fungous Parasites.

I. _____ ? This fungus is not injurious. It appears late in the fall when the grass

is dead. A few specimens were sent to J. B. Ellis to be named. He reported that it, probably, was the conidial stage of some of the Dothideaceae.

-- oOo --

ALOPESURUS PRATENSIS, L.

Meadow Fox-tail, English Fox-tail.

Distribution.

As one of its common names indicates, this is a native of Europe. It has recently been largely introduced into the eastern states, but is only sparingly cultivated in the west.

Habitat.

It is grown in moist meadows, pastures, and often in lawns. It is a valuable perennial grass for low, moist land. It does not thrive well without plenty of moisture.

Value as Forage.

It is, without a doubt, deserving of more attention than it ordinarily receives. Springing up readily after being cut it makes an excellent pasture grass, and is much more succulent than Timothy, which it closely resembles. It starts very early in the

spring furnishing feed almost two weeks earlier than Timothy. Its chemical composition is:

Fat,	3.36
Ash,	7.75
Crude Fiber,	23.78
Albuminoids,	10.81
Nitrogen-free extract,	54.30
Nutritive ratio	86.95.

Fungous Parasites.

I. *Puccinia graminis*, Pers. The rust was very injurious in the early part of the last season. All of the grass was mown before the formation of the teleutospores.

Uredospores, 16-23x24-35. For further description look under *Hordenum jubatum*.

-- oOo --

SPOROBOLUS CUSPIDATUS, TORR. (*Vilfa cuspidata*, Torr.)

Drop-seed Grass, Rush-grass.

Distribution.

Maine northward and westward through the United States and Canada, Minnesota, Iowa, Dakota, westward and southwestward. Found throughout South Dakota.

Habitat.

This grass generally grows in high, dry latitudes.

It is very plentiful on the western plains. In Dakota it is very common on the gravelly sides of knolls, but attains its most luxuriant growth in the edges of dry ravines.

Value as Forage.

Its agricultural value is not well known. Cattle are very fond of it. Its chemical composition is:

Moisture,	8.16
Fat,	<u>2.66</u>
Ash,	9.43
Crude fiber,	17.32
Albuminoid nitrogen,	10.88
Nitrogen-free extract,	59.71
Nutritive ratio, 78.36.	

Fungous Parasites.

I. *Puccinia vexans*, Farlow. Not a common species in South Dakota. It was found this summer at Brookings and Bangor.

Uredospores, subglobose, echinulate, 17 to 22 mm in diameter. Teleutosori, amphigenous, small, oval to linear and often confluent. Spores dark brown, smooth, subglobose to elliptical, not constricted, rounded at both ends; apex thickened; 28-42x18-23mm. Pedicel 36 to 100mm long, hyaline. Plate XXVII.

This differs somewhat from the ordinary descriptions of this species from the fact that there are but

very few one-celled teleutospores. In all of the material examined, but about a dozen one-celled spores have been found. But the other characteristics are so distinct that I have no hesitation in placing it under *P. vexans*.

II. *Phyllachora graminis*, (Pers.) Fuckl. Very common in many parts of the state. Found this year at Brookings, Forest City, Spring Lake, and Bangor. For general description and figures look under *Bouteloua oligostachya*.

-- oOo --

SPOROBOLUS CRYPTANDRUS, GRAY.
(*Vilfa cryptandra*, Trin.)

Drop-seed Grass, Rush Grass.

Distribution.

Mexico and Texas to Colorado, Nebraska, Dakota, and eastward to the New England States. Frequently found throughout South Dakota.

Habitat.

On the coast of New England and shores of the Great Lakes, it grows in sandy places. In the western states it grows commonly on the prairies and in the edges of low ground. I have found it most commonly

in ravines.

Value as Forage.

Its agricultural value is not known, at least no mention is made of it in any of the analyses that have been made. It is probably of little value.

Fungous Parasites.

I. *Puccinia sporoboli* (?), Arthur. This was frequently found by Schlosser and myself in the western part of the State, in Sept. 1892. Teleutospores epiphyllous, oblong to linear. Teleutospores, one-celled form only, subglobose to elliptical; apex, rounded to bluntly pointed, thickened, 21-30x30-44. Pedicels tinted. I have specimens from Gettysburg and Scranton and have not found any two-celled spores in either of them. The spores are larger than usually described and have longer pedicels. Plate XXVIII.

-- c0o --

CINNA ARUNDINACEA, L.

Indian Reed, Wood Reed-grass,
Sweet Reed.

Distribution.

Common in all of the northern states and extends,

on the Pacific Coast, as far south as California.

Habitat.

Moist woods and shaded swamps. In this state it is quite common on all bottom lands along rivers.

Value as Forage.

Its value as an agricultural grass is not very well known. Cattle are very fond of it when it occurs in pastures.

Fungous Parasites.

I. *Puccinia graminis*, Pers. Rare. All I have ever seen has been a few specimens collected and mounted with the grass by Mr. Douglas in 1889.

Uredospores 15-20x24-28mm. Teleutospores 16-22x36-56mm. For further description look under *Hordeum jubatum*. Plate XXIX.

II. *Phyllachosa graminis*, (Pers.) Fuckl. For description, look under *Bouteloua oligostachya*.

-- oOo --

CALAMAGROSTIS CANADENSIS, BEAUV.
(*Deyeuxia Canadensis*,)

Blue Joint-grass, Sand grass, Red top,
Canadian Small-reed, Fowl Meadow Grass.

Distribution.

Common in all of the northern portions of the

United States, in the Rocky Mountains and in British America.

Habitat.

It prefers low, cool, moist soil, and boggy meadows. Very common on river and lake bottoms in South Dakota.

Value as Forage.

In those regions in which it thrives best it is considered as one of the best native grasses. It is relished by cattle in the green state as well as when made into hay. Its composition is:

Water,	14.30
Fat,	<u>1.95</u>
Ash,	4.00
Crude Fiber,	37.45
Albuminoids,	5.80
Nitrogen-free extract, . .	36.50
Nutritive ratio, ..	54.25.

Fungous Parasites.

I. *Claviceps purpurea*, (Fr.) Tul. Sclerotia cylindrical, slightly curved, roughened, purplish, black outside and white within, 5x1/2mm or less.

CALAMAGROSTIS CONFINIS, NUTT.

Distribution.

Northward and westward from New York and Pennsylvania to the Rocky Mountains. It is probably found throughout South Dakota.

Habitat.

Low, moist ground, along streams and swamps.

Value as Forage.

No report has been made of its agricultural value as far as I know. In this state it forms much of the best hay of low bottoms.

Fungous Parasites.

I. *Claviceps purpurea*(?) (Fr.) Tul. Rare.
Sclerotia long, cylindrical, slightly curved, white within and purplish black on the outside, $2 \times 1/2$ mm or less in diameter.

-- oOo --

CALAMAGROSTIS LONGIFOLIA, HOOK.

Distribution.

It is common from the borders of the Great Lakes to Kansas, Dakota, westward and southward to Arizona.

Habitat.

This is a native of the dry plains of the interior of North America. It is very hardy and propagates by root stocks. Along the Missouri River in South Dakota it is a very common thing to find it growing on high sandy and gravelly knolls.

Value as Forage.

As long as there are other grasses on the river bottoms to be cut for hay this one will be left alone. Even in the dry, sandy regions it grows very rank and fibrous. Unless cut while very young cattle will not eat it to any great extent. In winter, however, there is considerable of it eaten by the cattle of the range.

Fungous Parasites.

I. *Puccinia graminis*, Pers. Very abundant and destructive wherever the grass was found last year.

Teleutospores 16-19x30-50mm. For further description look under *Hordeum jubatum*.

AVENA SATIVA, L.

Oats.

Fungous Parasites.

I. *Puccinia graminis*, Pers. This species of rust always does more or less injury to oats in this locality. For description look under *Hordeum jubatum*.

II. *Puccinia rubigo-vera*, (D.C.) Wint. A very common species, but not as destructive as *P. graminis*. For description, see this species described under *Hordeum jubatum*.

III. *Puccinia coronata*, Corda. Common and sometimes injurious. For description look under *Beckmania cruceiformis*.

IV. *Ustilago segetum*, (Bull.) Dittm. This is always common where oats are grown, but it has never done very much damage here yet. Plate XXVI.

-- oOo --

AVENA FATUA, L.

Wild Oats.

Distribution.

This plant is supposed to be a native of Europe but it is at present extensively introduced into near-

ly every state in the Union. In South Dakota it has been collected in but two places. At Brookings, it was introduced with some grass seed in a very limited quantity, while at and about Oak Lake and Lake Hendricks it is exceedingly common.

Habitat.

It is most common in cultivated fields of small grain and in waste places. It grows well wherever wheat or common oats will grow.

Value as Forage.

In California this is used a great deal as a hay grass. It is said to yield an excellent crop. Generally, however, it is considered to be a vile weed. Although not a perennial, it propagates itself year after year from the seed. In some states great care must be exercised in the rotation of crops in order to keep this weed in check.

Fungous Parasites.

I. *Puccinia graminis*, Pers. This rust was very common at Oak Lake last year.

Uredospores 14-16x24-33mm. Teliospores 16-20x33-52mm. For further description see *Hordeum jubatum*.

SPARTINIA CYNOSUROIDES, WILLD.

Cord Grass, Fresh water Cord Grass,
 Marsh grass, Bull grass, Thatch grass,
Slough grass.

Distribution.

Common across the whole continent, especially in the Atlantic States. It is found in all portions of South Dakota, particularly along the Missouri River

Habitat.

Grows in rich and sandy soils in river bottoms, lake banks, and the banks of streams in general. It is a very persistent thing when once established.

Value as Forage.

This grass is so tough and woody when it attains its full growth that cattle generally reject it; but if cut while young it makes very good feed. There is a great deal of it cut for hay in the Missouri river bottoms. A short distance below Scranton there is a large flat which has a good stand of this grass every year. Its digestible constituents are as follows:

Fat,	3.47
Albuminoids,	9.81
Nitrogen-free extract, . .	53.76
Nutritive ratio, 84.06.	

Fungous Parasites.

I. *Puccinia phragmites*, (Schum.) Kornicke. Sori amphigenous, large, oval, prominent, naked, black, and often confluent. Uredospores, elliptical and strongly tuberculate; 16-20x26-32mm. Teleutospores oblong to elliptical, slightly constricted; apex a little thickened, roundly or obtusely pointed, smooth, brown, 16-20x30-60mm. Pedicel 1 1/2 to 3 times the length of the spore. Plate XXX.

-- oOo --

SCHEDONARDUS PANICULATUS, (NAT.) COV.
(*Schedonardus texans*, Steud.)

Texas Spike Grass.

Distribution.

From Texas to Arizona, northward to Dakota and British America. In this state it is found only in the western part as far east as the Coteaus on the eastern side of the Missouri River.

Habitat.

It is confined entirely to the high and dry prairies and butes of the central plain.

Value as Forage.

It is at present of no agricultural value and the

probabilities are that it never will be. The lower leaves appear to be quite succulent in certain seasons but there are not enough of them to amount to much.

Fungous Parasites.

I. *Puccinia schedonardi*, K.&S. A very common fungus on the plains. Last year we collected it at Forest City only.

Uredospores globular, tuberculate, 19-20 μ m in diameter. Teliospores subglobose to oval, very lightly constricted, dark brown, 21-22x27-30 μ m. Pedicel tinted, about twice the length of the spore.

-- oOo --

BOUPELOUA OLIGOSTACHYA, TORR.

Blue Grama, Mesquit -grass, Muskit grass,
 Grama, Black Grama, Mosquit grass,
 Buffalo grass, White Grama.

Distribution.

From Texas and Mexico to southern California and from the Mississippi river to the mountains and northward into the British possessions. One of the commonest grasses of the Dakota prairies.

Habitat.

Its habitat is as variable as its distribution. It is found on the prairies and dry bottoms as well as on the mountains. Often grows mixed with *Agropyrum glaucum*.

Value as Forage.

With the exception of the little Buffalo grass, (*Buchloe dactyloides*) it is probably of all the grasses of the plains, the one most eagerly sought for by cattle. It is one of the most promising of our native grasses. Its composition is as follows:

Fat,	3.12
Ash,	7.81
Crude fiber,	22.65
Albuminoids,	8.58
Nitrogen-free extract,	57.84
Nutritive ratio,	84.49.

Fungous Parasites.

I. *Puccinia vexans*, Farlow. This fungus is frequently met with but it seldom appear in sufficient quantity to do much damage.

Teleutosori scattered on leaves and sheathes. The specimens found at Bangor, S. D. are entirely free from the one-celled teleutospores. Teleutospores subglobose to elliptical, little, if at all, constricted,

and smooth, 16-22x25-32mm. Pedicels 50-150mm long.

II. *Phyllachora graminis*, (Pers.) Fuckl. Very destructive to this host. It is very common in many parts of South Dakota, especially along the Missouri River, where it is often exceedingly injurious, as it was the past season.

Stroma scattered and confluent, penetrating the leaf and appearing on the under side, also, but not so prominent as upon the upper side; from oblong to irregular, often confluent, rugulose. Ostiola obscure. Ascigerous cells subseriate. Asci cylindrical, short stipitate, 70-80x7-8 1/2mm, paraphysate. Sporida obliquely uniseriate, ovate, simple, with one large irregular nucleus, hyaline, 4-5x6-10mm.

-- oOo --

BOUTELOUA RACEMOSA, LAG.

Fall Gama, Hairy Mesquit, Muskit-grass.

Distribution.

This species of Gama ranges from Mexico to British America westward to the coast and eastward to Tennessee. It is most common, however, in the Great Plain region.

Habitat.

Its habitat appears to be as extensive as its distribution. It grows well in Dakota on both low and upland, but never where it is very moist. It is a dry land grass and appears to be, like *B. oligostachya*, increasing with civilization.

Value as Forage.

One of our best and most promising grasses. It forms the main food of the vast herds of cattle which roam over the plains. Under the most favorable circumstances the product of this grass is small compared with many other wild and cultivated grasses, but stock are exceedingly fond of it and eat it in preference to any other grass grown with it. This species together with the *B. oligostachya* and the little Buffalo grass appear to cure naturally without being cut and dried. There are hundreds of cattle that live on these grasses in their natural condition upon the ground every winter. When the fall of snow is not too heavy they make a very good living.

Fungous Parasites.

I. *Puccinia vexans*, Farlow. This rust is very common in South Dakota every year, but has never been

found very injurious yet.

Teleutosori amphigenous, early erumpent, oblong, conspicuous, black, remains of ruptured epidermis not prominent. Uredospores subglobose 28-35mm in diameter; episore thick and tuberculate. Both one and two-celled teleutospores found in abundance in the same sori. The one-celled spores are subglobose to obovate with thick episores, which are considerably thickened at the apices, strongly tuberculate, 25-35x35-40mm. The two-celled spores are oval to oblong with smooth, thick episores which are very much thickened at the apices. The nuclear spots are very faint when present at all; 28-34x35-47mm. Pedicel about twice to thrice as long as the spore. Plate XXXI.

-- oOo --

BECKMANNIA CRUCAEFORMIS, NOST.
VAR. UNIFLORA? SCRIB.

Slough grass,

Wild Timothy.

Distribution.

Very common from Iowa northward and westward. It is real common throughout South Dakota.

Habitat.

It is confined to low wet ground, principally in the bottoms of ravines that have water in them a part

of the year. In Colorado it is very common along irrigating ditches.

Value as Forage.

It is seldom present in sufficient amount to be cut for hay. It is readily eaten in the green state by cattle and horses. I am unable to find a chemical analysis of it.

Fungous Parasites.

I. *Puccinia coronata*, Corda. Common in localities, but is very liable to be overlooked or to be slighted as an imperfect form of some black fungus.

Teleutosori amphigenous, oval to linear, minute, parallel, very slightly elevated, long covered by the unruptured epidermis, black. Uredospores, subglobose, echinulate. Teleutospores cuneate, scarcely constricted at the septum, obtuse to truncate above and crowned with one to several horn-like projections; epispore rather thin, smooth, 38-48x14-18mm. Pedicel short and fragile. Plate XXXIII.

BULBILIS DACTYLOIDES, (NUT.) RAF.
 (Buchloe dactyloides, Eng.)

Buffalo-grass, False Mesquit,
Early Mesquit.

Distribution.

A common grass on all of the region known as the plains. It is found from the Saskatchewan river to Minnesota and southward to Mexico. It is very common from the Jim River valley westward in South Dakota, and occasionally gets as far east as the Sioux River valley.

Habitat.

Most commonly found now at the foot hills, formerly reported from the high prairies also. It is most common at present in regions of the Black Hills.

Value as Forage.

This is a grass of which cattle are exceedingly fond. It is to be regretted that it is rapidly disappearing before the more hardy grasses with creeping root-stocks. It is of no value as hay because it seldom reaches a height of more than four inches. It is now found only in isolated localities in the neighborhood of foot hills, etc. As far as I know, no analyses have ever been made of it. Together with the

Gamas it forms much of the winter feed of range cattle.

Fungous Parasites.

I. *Cercospora seminalis*, E.& E. This appears to be a very common fungus in this region, and undoubtedly has much to do with the running out of the species, as it attacks and destroys the seed. It appears as a black smut like mass between the spines of the involucre. The mycelium penetrates the seed, which it blackens and destroys, sending up between the tips of the enclosed paleae a dense growth of fertile hyphae, which are of a pale olivaceous color, very long and sparsely branched, septate below, and bearing at their obliquely truncate tips, subhyaline, obclavate, granular, 3 to 9 septate, conidia, which are 50-100x 6-7mm. Plate XXXIV.

-- oOo --

PHRAGMITES VULGARIS, (LAM.) B.S.B.

Reed grass, Reed.

Distribution.

This grass is found all over the northern states in greater or less quantity. In South Dakota it is common as far westward as the Missouri River. It has

not been reported west of the Missouri River valley yet.

Habitat.

It is always found in low, moist ground, generally in the edges of streams and lakes, often growing in shallow water.

Value as Forage.

It has practically no value as an agricultural grass. Cattle sometimes eat it to a very limited extent when it occurs in pastures and ranges, but only when other grasses have become very short.

Fungous Parasites.

I. *Puccinia phragmitis*, (Schum.) Kornicke. This is a very common and destructive rust. Scarcely a specimen of the host was collected last year without being affected with this fungus.

Teliospores, mostly hypogenous but often amphigenous, oval to elongate and often confluent. Teliospores, oblong, bluntly pointed, slightly constricted; apex thickened. Pedicel long and hyaline or very slightly tinted. Plate II, Fig. 1.

II. *Cladosporium graminum*, Corda. Not injurious. For description look under *Homolocenchrus osyzoides*.

EATONIA PENNSYLVANICA, GRAY.

Eaton's Grass.

Distribution.

Throughout the northern part of the United States. Common in all portions of South Dakota, especially in the southeastern part.

Habitat.

Grows in low, moist woods and meadows, and is most common along banks of streams in South Dakota.

Value as Forage.

Not of much economic importance in this state because it is not common enough in the majority of the meadows. There is no chemical analysis of it on record. It is readily eaten by cattle when it occurs in pastures.

Fungous Parasites.

I. *Puccinia rubigo-vera*, (?) (D.C.) Wint. This has been found very frequently during the past summer. The fungus appears to injure the plant more in damp woods than in open meadows.

The rust differs considerable from the descriptions ordinarily given. The outline of the spores present

the same irregularity as those of the same species on *Agropyrum tenerum*, Wheat, and *Hordeum jubatum*, but the measurements are very different. The uredospores measure only 16-18x18-21mm; while the teleutospores are 12-16x25-48mm. The pedicels are also longer than usual on other hosts. Plate XXXV.

Specimens in the Herbarium of the University of Nebraska, collected and put up by S.M. Tracy at Starkville, Miss., are the same in measurements and pedicel characteristics as the ones collected by me at Brookings, S. D., in 1892.

II. *Cladosporium graminum*, Corda. Found only on dead leaves. For description and figures see *Homalocenchrus oryzoides*.

-- ooo --

KOELERIA CRISTATA, PERS.

Wild June grass, June grass.
Prairie grass.

Distribution.

From California and Oregon eastward to Pennsylvania. It is one of the commonest of South Dakota's prairie grasses, being found throughout the state.

Habitat.

Dry hills and prairies. Very common on the dry prairies of Dakota, Minnesota, and Nebraska, where it is often the principal grass. The upper Jim River valley possesses it in great abundance.

Value as Forage.

A very promising grass. Because it ripens about the first of July, it furnishes early feed both for grazing and hay purposes. In South Dakota, it is nearly always mixed with *Stipa spartea* and therefore is not much used for hay, because the spears of the latter are injurious to cattle and horses. Its chemical composition is as follows:

Moisture,	8.15
Fat,	<u>3.93</u>
Crude fiber,	22.58
Albuminoid Nitrogen,	6.35
Nitrogen-free extract,	53.68
Ash,	7.96
Nutritive ratio, 81.33.	

Fungous Parasites.

I. *Puccinia graminis*, Pers. This fungus has been found to be very destructive in certain localities in South Dakota. During the past season in and about Brookings it was destructive alike to the native and the cultivated varieties. One plat of the grass was

nearly ruined, and what young growth came up in the fall was again vigorously attacked.

Uredosori scattered, oval to oblong, orange yellow
Spores elliptical and obovate, echinulate, 18-20x27-33
mm.

The same can be said of the characteristics of the teleutosori in this and the same species found on *Poa tenuifolia*, in the cultivated variety. Spores clavate to narrowly elliptical, with thickened, rounded or bluntly pointed apices, dark brown, slightly constricted, 16-20x36-47mm. Pedicel tinted.

II. *Epichloe typhina*, Pers. A very common and destructive fungus. It could be picked up anywhere on the prairie about Brookings the past season, while at Sand Lake, Gettysburg, Forest City, Bath,,and Redfield I found it very common. It appears in the latter part of June, on the upper leaf sheaths, forming a white, cylindrical expansion immediately above the nodes, from 1 to 2 inches in length. As the thing develops it turns yellow, deep orange, and finally to black.

Stroma pale, thin surrounding the sheathes and included culms of the grass, extending longitudinally

from 1 to 2 inches and bearing in the early stage of growth, small, ovoid, hyaline conidia which are 4-5x3mm. It is finally covered with a layer of semi-immersed, soft, carnose-membranaceous, yellow perithecia with somewhat prominent ostiola. Asci cylindrical, (somewhat longer than usually described,) 160-250x6-8mm, slightly narrowed above, with the apex truncate and capped with a subhemispherical hyaline crest. Sporidia 8 in an ascus, filiform, hyaline, multinucleate and nearly as long as the asci. Plate XXXVI.

-- oOo --

DISTICHLIS SPICATA, (L) GREEN.
VAR. STRICTA, THUR.

Salt grass, Sand grass, Alkali grass,
Spike grass.

Distribution.

From Minnesota and Iowa westward to the coast, and from Mexico and Texas northward through the Rocky Mountains. Common in all portions of South Dakota.

Habitat.

It grows well, forming a dense sod on alkaline soils on the plains. Very common on river and lake bottoms, where it is often the only grass.

Value as Forage.

This grass is of but little agricultural value as it hardly grows tall enough for hay and cattle seldom eat it from choice. Its chemical analysis shows:

Moisture,	7.95
Fat,	2.72
Ash	7.98
Crude fiber,	22.80
Albuminoid nitrogen,	7.56
Nitrogen-free extract,	58.94
Nutritive ratio,	82.39.

Fungous Parasites.

I. *Puccinia* n. sp. This rust has been found very destructive in several portions of the state the past summer. There are two species of *Puccinia* recorded on this host, *P. graminis* and *P. distichlidis* n.sp. E.& E., but it can be neither of these. It seems rather odd, too, because we found but one species in all of last summer's collection. Specimens were obtained from Sand Lake, Iroquois, Huron, Blunt, Brookings, and Forest City, all of which have the same peculiar characteristics.

Teleutosori, commonly amphigenous but mostly epigenous, oval to elliptical, often confluent, very prominent, black. Uredospores, subglobose, epispore thick, minutely roughened, 16-24mm in diameter. Tel-

autospores broadly elliptical to clavate, slightly constricted; apex roundly to bluntly pointed and slightly thickened, 17-22x30-48mm. Pedicel nearly colorless, 48-100mm in length. Plate XXXVII.

While at the State University of Nebraska, I had the privilege of examining specimens of rust on this host, collected and put up by F.D. Kellsey, from Helena, Montana. These he calls *P. graminis*. They are evidently the same as my specimens, but it will be readily seen from the description that they cannot be *P. graminis*. The only difference between his specimens and mine is in the fact that the sori on his are more amphigenous than mine. This I think is due to the fact that his specimens are much more injuriously affected.

II. *Phyllachora graminis*, (Pers.) Fuckl. Very destructive to this host during the past season. More or less of it was found wherever the host grew. On Sand Lake bottoms in August, and in the neighborhood of Forest City and LeBeau in September, I found it very destructive.

Stroma appearing on both sides of the leaves, but more prominent on the upper side, black, scattered

or confluent, oval to very uneven in outline, rugulose. Asci short stipitate, cylindrical, 75-90x4-6mm. Sporidia obliquely uniseriate, hyaline. For figures look under *Bouteloua oligostachya*.

-- oOo --

DACTYLIS GLOMERATA, L.

Orchard grass, Rough Cock's-foot.

Distribution.

A naturalized grass from Europe. It has a very wide distribution, growing in every country of Europe, and in Asia and Africa, according to authentic reports. It is now introduced into nearly all states of the Union.

Habitat.

It thrives well on a great variety of soils, and always has an abundance of green leaves at its base, while the culms are generally thin upon the ground.

Value as Forage.

This is one of the most popular of our meadow grasses. Its rich growth of root leaves make it a good pasture grass, while it also appears early in the spring. There is probably no grass that springs up so soon after being mowed as this one. Its chemical

composition is:

Fat,	3.56
Ash,	7.24
Crude Fiber,	23.08
Albuminoids,	9.91
Nitrogen-free extract,	56.03.
Nutritive ratio, 86.73.	

Fungous Parasites.

I. *Puccinia graminis*, Pers. Somewhat destructive to this host in this vicinity the past season.

Uredosori large, for this species, elliptical to linear, scattered, principally on the leaves. Spores, echinulate, obovate to elliptical, 16-19x26-31mm.

Teleutospores clavate to narrowly elliptical, constricted slightly, vertex strongly thickened, pointed bluntly or rounded, narrowed to the pedicel, smooth chestnut brown, 16-21x38-47mm. Pedicel about the length of the spore, strongly colored.

-- oOo --

POA NEMORALIS, L.

Distribution.

Labrador to northern Maine and Vermont and westward to Iowa and Dakota. It has been collected in this state at Lake Hendricks, Rapid City, and Sand Lake.

Habitat.

Shady places in edge of woods, lake and river banks.

Value as Forage.

It appears to be a grass that cattle would naturally relish. I have made no observations upon it, and think that there have been no chemical analysis made of it.

Fungous Parasites.

I. *Erysiphe graminis*, D.C. This fungus was collected by Williams at Lake Hendricks. It is not developed enough to have perithecia present. It is of no economic importance. For description look under *P. caesia*.

-- oOo --

POA SEROTINA, EHRH.

False Red-top, Fowl Meadow-grass.
Duck-grass.

Distribution.

Most common in the northern states from New England to Colorado; also found in all the mountainous districts. In this state it has been collected only at Brookings, Flandreau, and Lake Hendricks.

Habitat.

It grows best in the native state in rich, aluvial ground along banks of streams, but it is extensively cultivated in many of the western states. It is rather a promising grass for South Dakota.

Value as Forage.

It is very highly recommended as a forage grass in both the eastern and western states. Even on rich bottom lands it never grows so rank but that the stalk is tender enough for feed. Its analysis shows the following composition:

	Fresh.	Dry.
Water,	14.30	
Fat,	2.43	2.84
Ash,	3.65	4.23
Crude fiber,	17.37	20.85
Albuminoids,	5.37	6.27
Nitrogen-free extract,	56.40	65.81
Nutritive ratio, 73.90 and 86.21.		

Fungous Parasites.

I. *Puccinia Rubigo-vera*, (D.C.) Wint. Rhydburg's specimens from the Black Hills seem to show a decided injury by this fungus, as nearly all of them were badly affected. The cultivated variety was, however, entirely free from parasitic attacks during the past season. See *P. rubigo-vera* under *P. alsodes* for full description.

POA PRATENSIS, L.

Kentucky Blue grass, Blue grass,
Green grass, June grass,
Smooth Meadow grass.

Distribution.

Native in the mountains from northern Pennsylvania to New England and northward. It is now introduced across the continent. Cultivated quite extensively in the eastern half of South Dakota.

Habitat.

This grass varies greatly with the character of the soil upon which it is found. Undoubtedly it thrives best in clay land, but grows well in a great variety of soils. It is found quite extensively introduced into pastures and meadows in South Dakota.

Value as Forage.

Its value as a forage is too well known to need any further comment. Also the wide area over which it has been introduced into meadows speak volumes for it. Its composition, according to Richardson of the United States Department of Agriculture, is as follows:

Fat,	2.86.
Ash,	5.20
Crude fiber,	27.94

Albuminoids,	11.54
Nitrogen-free extract, . . .	52.46
Nutritive ratio, 86.06.	

Fungous Parasites.

I. *Uromyces dactylidis*, Otth. (*Uromyces poae*, Rabeuh.) This has been quite a common fungus in this locality the past season. I collected it for the first time on the 25th of June in a low meadow. During autumn it was very common on the shady sides of the College buildings, but it did no damage anywhere else. Only the uredo stage was collected.

Uredosori epiphyllous, small, oval to elongated and covered by the epidermis for sometime. Spores subglobose to oval, echinulate, 15-17x20-24mm.

II. *Erysiphe graminis* D.C. Common but not hurtful. It appears exclusively in shaded places, on the north side of buildings, etc., as a white, felty, mould on the upper side of the leaves. I have found no perithecia.

III. *Vermicularia denudata*, (?) Schw. This is usually not very destructive. It does not appear until late in the season.

POA ALSODES, GRAY.

Wood Spear-grass.

Distribution.

From New England to Pennsylvania and westward to Colorado. It has never been collected in South Dakota outside of the Black Hills region, Chamberlain, and Cheyenne River.

Habitat.

Grows in rich soil in shady places along banks of streams.

Value as Forage.

This is reported to be of no agricultural value. Its chemical analysis shows the following composition:

Moisture,	8.72
Fat,	<u>2.13</u>
Ash,	9.73
Crude fiber,	23.30
Albuminoid nitrogen,	3.32
Nitrogen-free extract,	61.52
Nutritive ratio,	73.37.

Fungus Parasites.

I. *Puccinia rubigo-vera*, (D.C.) Wint. This fungus I have never collected on this host. Mr. Rhydburg kindly allowed me to examine his collection of grasses made in the Black Hills of South Dakota during the summer of 1892. I found his specimens

badly affected by this fungus. I am therefore inclined to believe that it is quite common. The specimens are in the uredospore stage, with the teleutospores beginning to appear rather sparsely.

Uredosori, small, rounded to oblong, amphigenous, irrumpent. Uredospores, subglobose, epispore rather thick for this species, echinulate, 15-20x16-22mm. Teleutosori, black, small, rounded to oval, mostly hypogenous. Teleutospores cuniform, constricted; lower cell attenuate to a very short pedicel; epispore smooth, thickened at apex, which is truncate to irregularly conical, 34-42x16-22mm. Plate XXXVIII.

-- oOo --

POA CAESIA, SMITH.

Distribution.

Found in the Rocky Mountains and eastward. It has been reported in this state only from the Black Hills.

Habitat.

In mountainous districts, on peaks and along foothills. It does not occur in any great quantities anywhere.

Value as Forage.

It probably is of no agricultural value, at least its value has not been reported to my knowledge; nor have any analyses been made of it. Its growth is not large enough to render it of much use.

Fungous Parasites.

I. *Erysiphe graminis*, D. C. Judging from Mr. ~~Rydburg~~'s collection, this fungus must have been very common on this host during the past season in the Black Hills of South Dakota, as nearly all of his specimens were more or less affected.

Epiphyllous. Mycelium dense, persistent, white, and partially covering the perithecia which are brown to black, large, subglobose, 160-200mm, and numerous; appendages of perithecia not very numerous, short with the exception of those on the under side which are interwoven with the mycelium. Asci oval to oblong with short, straight or variously curved pedicels; 15-20mm.

The specimens show no sporidia, on the other hand, the asci have only homogenous, granular contents. See Plate XXXIX.

POA TENUIFOLIA, NUTT.

Bunch grass.Meadow Grass.

Distribution.

From Colorado to California and Oregon. Often cultivated eastward. It has not been found native in this state yet.

Habitat.

In Colorado it occurs in two well marked forms in the mountains. It grows most commonly in meadows.

Value as Forage.

Reported as being, in Colorado, one of the most promising of bunch grasses. It grew well in South Dakota under cultivation the past season. Its chemical composition is as follows:

Moisture,	8.30
Fat,	<u>2.92</u>
Ash,	9.45
Crude fiber,	19.40
Albuminoid nitrogen,	8.76
Nitrogen-free extract,	59.47
Nutritive ratio,	86.22.

Fungous Parasites.

I. *Puccinia graminis*, Pers. This rust was very destructive during the past season, in the grass experiment conducted by the Experiment Station. The plat seeded to *P. tenuifolia* was nearly ruined. The

uredo stage of the rust appeared even on the young autumn growth, and was injurious until the grass was killed by frost.

Uredosori amphigenous, linear to oval, and often confluent, orange yellow. Spores obovate to elliptical, echinulate, 16-19x24-33mm. Teleutosori rather inconspicuous for this fungus. This can be easily explained. In this case it did not have room and time to develop as it ordinarily does on the sheathes and culms, but because the grass had only been growing one year it was confined to the leaves. This probably is the reason for the dwarfing of the sori. Spores elliptical to clavate, slightly constricted, dark brown. Apex thickened, pointed or rounded, 16-21x30-44mm. Pedicel tinted.

-- oOo --

BROMUS UNIOLOIDES, WILLD.
(BROMUS SCHRADERI.)

Rescue Grass, Schrader's Brome-grass.
Australian Prairie -grass, Australian Oats.

Distribution.

Introduced into the southern states from Australia. It is now extensively cultivated there and sometimes is found further north.

Value as Forage.

It is not adapted to the cold and severe winters of our northern states. Where it thrives best, it makes the most of its growth during the winter months and becomes ready to cut in April. It makes a fine growth of leaves, and is greedily eaten by stock. Last year it produced a good crop of hay from seed which fell to the ground the previous season. Its composition in the dry state is:

Fat.,	3.58
Ash,	9.74
Crude fiber,	20.59
Albuminoid,	13.62
Nitrogen-free extract, . .	52.47
Nutritive ratio,	92.42.

Fungous Parasites.

I. *Erysiphe graminis*, D.C. Rare. It produces a grey, felt-like mass upon the lower leaves and culms.

Mycelium tinted brown, septate, dense, branching diffusely, especially at the ends where the subglobose 7-9mm conidia are produced. Plate XL.

-- oOo --

AGROPYRUM TENERUM, VASEY.
(*A. repens* var. Beauv.)

Wheat grass, Couch Grass, Quack Grass,
Quitch Grass, Blue-joint.

Distribution.

Prevails in the Rocky Mountain region from New Mexico to Oregon,- "Grass and Forage Plants of the United States," Vasey. Quite common in South Dakota and eastward into Minnesota.

Habitat.

It grows mostly in low, moist and waste places. Very often occurs along with *A. repens* and *A. glaucum*, from which it differs by growing in bunches and having a narrower spike.

Value as Forage.

This is one of the most promising grasses for South Dakota. It grows well and furnishes a good crop of hay when cultivated, but is badly affected by fungous diseases. Its composition is:

Moisture,	7.86
Fat,	2.04
Ash,	6.28
Crude fiber,	20.20
Albuminoid nitrogen, . . .	6.15
Nitrogen-free extract, . .	65.33
Nutritive ratio, 83.98.	

Fungous Parasites.

I. *Puccinia graminis*, Pers. Very abundant on this host in various portions of the state the past summer.

Teleutosori generally confluent in long lines on the culms and sheathes. Often so plentiful that the whole circumference of the sheathe or culm is a solid, black mass. It often extends into the spike. Spores clavate, slightly constricted, with thickened, rounded, or pointed apices. Pedicels tinted, generally as long as the spore; 16-20x35-60mm.

II. *Puccinia rubigo-vera*, D.C. I have not found this rust on any of the native forms, but it was unusually injurious to cultivated forms on the College Farm, during the past summer.

Uredo- and teleutosori amphigenous, oblong and commonly confluent, long covered by the unbroken epidermis, and therefore not very prominent. Teleuto-spores cuneiform to oblong and slightly constricted at the septum; apex thickened and rounded to obliquely pointed, 13-19x25-40mm. Pedicel short and deeply tinted.

III. *Claviceps purpurea*, (Fr.) Tul. Not as common on this species as it is on the other species of this genus.

AGROPYRUM GLAUCUM, R. & S.
(*A. repens*, var. *glaucum*, Boiss.)

Wheat Grass, Colorado Blue-stem, Blue Grass,
Wild Quack-grass, Gumbo -grass.

Distribution.

Kansas, Nebraska, Dakota, and westward. A very common grass throughout South Dakota.

Habitat.

It grows commonly on the prairies, and in the edges of poor soiled bottoms. It is the first grass that springs up in the dried up lake beds in the various ranges of hills in South Dakota and neighboring states. During the past year, 1892, it has appeared much more profusely on the prairies than heretofore. This is made still more prominent by the fact that during this year the wet weather has induced it to head out more profusely than during the former dry years.

Value as Forage.

When cut early in the season, it is reported to be good feed; but when left until it becomes ripe, it is hard and woody. It is one of the most important grasses in the western part of the state, forming at least one-half of the hay cut. It often appears in

uncultivated grounds to such an extent, that, after two or three years of rest, good crops of hay are cut upon them. It is, however, not troublesome in waste places like *A. repens*, because it has no root stocks. Its chemical analysis is as follows:

Moisture,	7.91
Fat,	2.57
Ash,	7.09
Crude fiber,	19.65
Albuminoid nitrogen,	7.32
Nitrogen-free extract,	63.37
Nutritive ratio, 85.97.	

Fungous Parasites.

I. *Puccinia graminis*, Pers. This has been found to a limited degree on the native host in this vicinity during the past summer. But on the cultivated variety in the grass experiment conducted at the South Dakota Experiment Station, the fungus was very destructive. Even the young growth in the fall was slightly injured.

Teleutosori, elliptical or linear, soon black or naked. The spores average the largest of any of the *P. graminis* that I have examined. They do not over-run the measurements ordinarily given, but they average much higher, 16-21x36-60mm.

II. *Cladisporium graminum*, Corda. Found on the old glumes in ergoted heads late in the fall, giving

to the head a blackened, dirty appearance. For description see *Homalocenchrus oryzoides*. Plate XLI.

III. *Claviceps purpurea*, (Fr.) Tul. Exceedingly common.

IV. *Epichloe typhina*, (?) (Pers.) Tul. This appears to be doing considerable injury in a single locality this year. The fungus, as far as it has developed thus far, does not correspond exactly to *Epichloe* because the grass in a majority of cases has headed out as usual and the stroma appears on the destroyed heads of the grass. In nearly every case, however, if the plant has headed, the sheathe at the imbrication is more or less affected. I think that the fungus started while the head was still in the sheath but owing to the fact the plant was very vigorous the fungus was not able to hold it in check. A few ovoid, hyaline conidia have been seen.

-- oOo --

AGROPYRUM CANINUM, R. & S.

Awne'd Wheat-grass.

Distribution.

This grass is indigenous only along the northern

border of the United States, It is found introduced in some of the regions southward. Common throughout South Dakota.

Habitat.

Very common on prairies and dry low lands. It generally occurs with the other species of this genus.

Value as Forage.

Its value as an agricultural grass is as little known, perhaps, as any of the species in this genus. The texture appears to be about the same as *A. glaucum*, but there is never such a good stand of it.

Fungous Parasites.

I. *Puccinia graminis*, Pers. Rather rare. For description look under *Hordeum jubatum*.

II. *Claviceps purpurea*, (Fr.) Tul. Very common.

-- oOo --

TRITICUM VULGARE, L.

Wheat.

Fungous Parasites.

I. *Puccinia graminis*, Pers. Always very common and often injuring the yield of wheat one-fourth to one-half. The value of the straw for fodder is ser-

iously impaired by this rust. For description look under *Hordeum jubatum*.

II. *Puccinia rubigo-vera*. Rather rare. For description see *P. rubigo-vera* on *Hordeum jubatum*.

III. *Ustilago tritici*, (Bull.) Ditm. This is always very common here, but seldom does much injury.

IV. *Tilletia foetens*, (?) (E. & C.) Trel. This smut is at times very injurious. Last year at Flandreau I saw a piece of grain, belonging to an Indian, which was at least one-half smutted. In Brown County it was very injurious from 1883 to 1886. Since that time attention has been paid to seed treatment which has effectually done away with the smut. Besides reducing the yield, it also reduces the price from five to fifteen cents per bushel. Plate XXVI, Fig. 15.

-- oOo --

HORDEUM JUBATUM, L.

Squirrel-tail grass, Fox Tail.

Distribution.

Extends throughout the northern part of the United States, but it is most common on the western plains, and in Colorado. Very common throughout South Dakota.

Habitat.

Grows in low, moist, and waste places. It is said that, in Colorado, over irrigation has produced a great distribution of this species in recent years. (Bulletin No. 12, Colo. Agr'l College and Exp. Sta.)

Value as Forage.

It has become a very troublesome weed in some places in the west during recent years. Growing, as it does, in low places, it becomes mixed with other meadow grasses and considerably reduces their value for fodder. The long, barbed, awns cause considerable difficulty in feeding as they very often cause throat and mouth troubles in horses and cattle. Analysis of the grass at the Colorado Station has shown the following composition:

Moisture,	7.29
Fat,	<u>2.71</u>
Ash,	13.05
Crude fiber,	15.72
Albuminoid nitrogen, . . .	7.51
Nitrogen-free extract, . .	61.01
Nutritive ratio,	84.26.

Fungous Parasites.

I. *Puccinia graminis*, Pers. Very injurious to this grass. Nearly all of the summer's collection at this Station has shown the grass badly affected

by the rust. Even the young autumn growth has often been noticed to be badly injured.

The teleutosori oval to linear, and often confluent in long lines upon the culms and sheathes. Spores dark brown, slightly constricted, and considerably thickened at the apex. Pedicel yellowish-brown into which the inferior spore gradually converges, as long or a little longer than the spore.

II. *Puccinia rubigo-vera*, (D.C.) Wint. Not so common on this host as *P. graminis*, but what specimens have been found have been badly injured. Specimens were found last year at Oakwood, Brookings and Scranton. The young autumn growth was very badly injured in each case.

Uredosori oblong to linear and although occurring on both sides of the leaves are much more common on the lower side. Spores oblong, echinulate, and yellow, 15-18x20-28mm. Teleutosori oval, confluent, and black. Long covered by the unruptured epidermis. Spores, oblong, slightly constricted, and much thickened at the apex. Truncate to obliquely conical, brown, smooth, and very short pedicelled to which the inferior spore

is attenuate. The spores are very irregular in outline and size. The apex in many is cordate, while in others it is conical; 37-52x15-20mm.

-- oOo --

ELYMUS VIRGINICUS (?) L.

Syme-grass, Smooth Rye-grass.
Ferrell-grass, Wild Rye.

Distribution.

This perennial grass is a native of the southern states, and is also found in the majority of the northern states, but not so common as it is further south. It grows in all portions of South Dakota.

Habitat.

Often forms a considerable portion of the native meadow grass in many of the southern states. In the north it is, however, confined more nearly to the banks of wooded streams and lakes. It prefers a low, moist, aluvial soil.

Value as Forage.

It makes rather a coarse hay, but is readily eaten by stock. No chemical analysis has been made of it as far as I know.

all I could find, which was about twenty-five plants

affected with the fungus.

The asci are very variable in length, measuring

from 4-7x180-300mm.

III. *Puccinia pubigo-vera*, (D.C.) Wint. Not very

common on this. The only time it has been reported on

this host is from Oakwood, S. D. Teleutospores 20-28x

32-44mm. For further description look under *Hordeum*

pubatum.

IV. *Claviceps purpurea*, (Fr.) Tul. Very common.

-- 000 --

ELVUS CANADENSIS, T.

VAR. *GLAUCOPHOLUS*, GRAY.

Canada Lyme-Grass, Wild Rye,

Terrell-Grass.

Distribution.

Very common across the continent. It is not

abundant enough in South Dakota to form any consider-

able amount of hay.

Habitat.

Rich bottoms, river banks, shaded woods, and waste

places.

Value as Forage.

Rather coarse for hay, unless cut early, when it makes fair feed. In some localities in the west it is extensively cut for hay. Its composition is as follows:

Moisture,	8.03
Fat,	2.03
Ash,	10.75
Crude fiber,	19.88
Albuminoid nitrogen,	7.09
Nitrogen-free extract,	60.25
Nutritive ratio,	82.35.

Fungous Parasites.

I. *Puccinia graminis*, Pers. A common fungus on this host, but it has never been reported as very destructive. It makes its appearance on the sheathes and the leaves. Uredospores measure 15-17x29-38mm. Teleutospores 17-19x41-50mm. This rust has been found only on the species.

II. *Phyllachora graminis*, (Pers.) Not common, although I found one clump on this variety on the shady banks of Oakwood Lake that was nearly covered by it. For description look under *Euteloua oligostachya*

III. *Puccinia rubigo-vera*, (D.C.) Wint. A rare fungus on this host here. I do not know of its ever being collected excepting when I found these specimens

in the Horticultural Gardens at Brookings. There it was abundant on one clump of the grass.

Uredosori mostly hypogenous, but spores abundant with teleutospores above; oblong to linear, erumpent, slightly elevated, light brown. Teleutosori amphigenous, but mostly epigenous, oblong to linear, often crowded and confluent in long lines, long covered by the unbroken epidermis, black, surrounded by numerous, dark brown paraphyses. Uredospores subglobose, echinulate, 20-25mm. Teleutospores cuneiform, oblong to elliptical, generally slightly constricted, tapering below; apex truncate to obtusely and obliquely pointed, 18-24x 38-50mm. Pedicel short and somewhat tinted. Plate XLII.

IV. *Cladosporium graminium*, Corda. Not of any economic importance. Found only on the subliving portions of the host. For general description look under *Homalocenchrus oryzoides*.

V. *Claviceps purpurea*, (Fr.) Tul. Exceedingly common throughout the state.

ELYMIUS STRIATUS, WILLD.

Distribution.

From the Atlantic Ocean to the Rocky Mountains, in the northern portion of the United States. It has been reported for South Dakota from Sand Lake, Tecoma Park, Brookings, Oakwood, Forest City, and Spring Lake.

Habitat.

Rocky woods and banks. Most commonly found here in moist woods and river banks.

Value as Forage.

No notes have been published regarding its agricultural value. It does not occur in large enough quantity anywhere in South Dakota to be of much use. It has the appearance of being a grass that cattle would relish about as well as any other species of this genus, but its habitat would prevent it from ever becoming of any agricultural importance.

Fungous Parasites.

I. Puccinia sp. Rare and very liable to be overlooked because it is not at all conspicuous.

Sori small, black, oblong to linear, long covered by the epidermis, appearing on both sides of the leaf,

but much more prominent on the upper side. Uredospores oval; epispore oblong, very slightly constricted; a little thickened above, truncate to bluntly, irregularly, and obliquely pointed; 38-50x19-24mm. Plate XLIII.

This approaches two species of rusts quite closely but not near enough so that I feel able to call it either. Ellis and Tracey describe a species of rust, *Puccinia Apocrypta*, on *Asprella hystrix*, which corresponds very well to this one with the exceptions of the measurements of the teleutospores which they find to be 14-18x24-36mm. This is described in the *Journal of Mycology*, v. VI, p. 76. J. B. Ellis describes a *P. montanensis* on *Elymus condensatus*, in *Journal of Mycology*, v. VII, p. 274, which corresponds very well in everything except sori characteristics.

II. *Cladosporium graminium*, Corda. Not very injurious. This fungus appears as a black mass at the apex of the seed, growing and receiving its nourishment entirely from the remains of the stamens, style and stigma.

Hyphae, olivaceous, nodulose, septate, simple in tufts of 2-5, 100-160x4-6mm. Conidia concolorate,

1-polyseptate, broadly ovate to oblong, very variable.

Plate XLIV.

-- oOo --

S U M M A R Y .

I. From an economic point of view, the fungous parasites of South Dakota are decidedly important.

Judging from recent reports, and from the little work that has been done along this line of late, we have as much to fear from plant diseases in this region as in any of the neighboring states, notwithstanding the fact that we do not usually look for a great deal of parasitism in such a dry prairie region.

II. The ravages of all of these parasites can be materially hindered by general sanitation, while many of them can be completely controlled by the proper use of fungicides. The "Blights," "Mildews," and "Black Fungi" can be partially subdued, while the smuts can be rendered of little consequence, by the aid of chemicals. The "Rusts," however, have baffled all attempts to exterminate them. Indeed, all treatments seem to favor, rather than prevent their development.

III. Our most injurious parasites belong to the order Unedineae, and to the genus Puccinia.

IV. Scientifically, our fungi are very peculiar

and interesting. The peculiar environments render some species exceedingly variable.

V. Upon the seventy-two species of forage plants mentioned here, there have been found fifty-one distinct species of fungi. Three of the latter have never before been described, and six or seven more are questionable. In a few instances, as many as five species of fungi have been found on the same host plant, while it has been a very common thing to find a single species of fungus inhabiting a dozen hosts. Counting each one of these, we have in all one hundred twelve specimens recorded and described.

-- oOo --

A P P E N D I X .

A LIST OF GRASS-FEEDING INSECTS.

ARACHNIDA.

_____ (?)

Bryobia pratensis.
Phytoptus pyri.

ORTHOPTERA.

Acrididae.

Acridium fontalis, Scudd.
Arphia teporata, Scudd.
Arphia sulphureas, Scudd.
Arphia tenebrosa, Scudd.
Aulocara sp.
Aulocara elliotii, Thos.
Boöpedon nubilum, Thos.
Brachystola magna, Girard.
Carolophitus hirtipes, Say.
Circotettix carlingianus, Thos.
Circotettix undulatus, Thos.
Camula pellucida, Scudd.
Chimarocephala viridifasciata, DeGeer.
Cloealtis viridis, Thos.
Cloealtis punctulata, Thos.
Cloealtis curtitenis, Harr.
Dendrotettix longipennis, (M.S.) Riley.
Dissosteira spurcata, Saus.
Dissosteira longipennis, Thos.
Dissosteira obliteriata, Thos.
Dissosteira carolina, Linn.
Derotema haydenii, Thos.
Encoptolopus sordidus, Burm.

Euprepocnemis nebrascensis, Thos.
Gomphocerus clepsydra, Scudd.
Hippiscus corallipes, Hald.
Hippiscus rugosus, Scudd.
Haderotettix trifasciatus, Say.
Hesperotettix viridis, Thos.
Mermiria brachyptera, Scudd.
Mermiria neo-mexicana, Thos.
Melanoplus differentialis, Thos.
Melanoplus femoratus, Burn.
Melanoplus bivittatus, Say.
Melanoplus foedus, Scudd.
Melanoplus packardi, Scudd.
Melanoplus angustipennis, Dodge.
Melanoplus cineris, Scudd.
Melanoplus luridus, Dodge.
Melanoplus infantalis, Scudd.
Melanoplus femur-rubrum, DeGeer.
Melanoplus spretus, Thos.
Melanoplus devastator, Scudd.
Melanoplus ponderosus, Scudd.
Melanoplus scriptus, Scudd.
Melanoplus gladstonii, (M.S.) Riley.
Melanoplus atlantis, Riley.
Oxycoryphus obscurus, Thos.
Pezotettix albus, Dodge.
Pezotettix borealis, Scudd.
Pezotettix enigma, Scudd.
Phlybostrima parva, Scudd.
Phlybostroma 4-maculata, Thos.
Schistocerca americana, Drury.
Spharagemon aequale, Scudd.
Spharagemon collare, Scudd.
Stenobotherus gracilis, Scudd.
Stenobotherus aequalis, Scudd.
Stenobotherus maculipennis, Scudd.
Tettix granulatus, Kirby.
Trimerotropis fontana, Thos.
Trimerotropis pseudofasciata, Scudd.
Trachyrhachis pardalina, Saus.
Trachyrhachis kiowa, Thos.

Locustidae.

Conocephalus ensigner, Harr.
Cyrtophyllus concavus, Harr.

Microcentrum retinervis, Brum.
 Ochelimum agile, DeGeer.
 Scudderia curvicauda, DeGeer.
 Xyphidium nigropleurum, Bruner.
 Xyphidium brevipennis, Scudd.
 Xyphidium fasciatum, DeGeer.
 Xyphidium saltans, Scudd.
 Xyphidium attenuatum, Scudd.

Gryllidae.

Centrophilus castaneus, Scudd.
 Gryllus neglectus, Scudd.
 Nemobius vittatus,

THYSANOPTERA.

(?)

Limothrips poaphagus, "M. S." Riley.

HEMIPTERA.

I. (Heteroptera.)

Pentatomidae.

Oebalus pugnax, Fabr.

Lygaeidae.

Blissus leucopterus, Say.
 Geocoris sp.
 Lygaeus sp.

Capsidae.

Episcopus ornatus, Rent.
 Leptoterna amoena, Uhl.
 Leptoterna dolobrata, Linn.
 Oncognathus binotatus, Howard.

II. (Homoptera.)

Membracidae.

- Publilia concava, Say.
- Ceresa bubalus, Fabr.
- Ceresa diceras, Say.
- Stictocephala inermis, Fabr.

Cercopidae.

- Aulagizes irrorata, Fab.
- Clostoptera obtusa, Say.
- Diedrocephala coccinia, Foster.
- Diedrocephala versutus, Say.
- Diedrocephala mollipes, Say.
- Tettigonia microglyphica, Say.
- Ptyches lineatus.

Brythoscopidae.

- Agallia 4-punctata, Prov.
- Agallia sanguinolenta, Prov.

Jassidae.

- Allygus irroratus, Say.
- Athysanus exitosa, Uhl.
- Thysanus sp.
- Cicadula nigrifrons.
- Cicadula exitiosa, Uhl.
- Cicadula 4-leniata.
- Deltocephalus inimicus, Say.
- Deltocephalus sayi, Fitch.
- Deltocephalus melsheimeri.
- Deltocephalus retrosus, Uhl.
- Deltocephalus debilis, Uhl.

Aphididae.

- Aphis maidis, Fitch.
- Aphis madi-radiciis.
- Aphis annuae, Oestl.
- Colophora eragrostoides, Middleton.
- Lachnus strobi, Fitch.
- Rhizobius poae, Thos.

Rhopalosiphum nymphaeae, Linn.
 Schizoneura panicola, Thos.
 Siphonophora setariae,
 Siphonophora avenae.
 Tetraneura graminis, Monell.
 Toxoptera graminum.
 Tychea panici, Thos.

Coccidae.

Dactylopius herbicola. (Australia.)
 Rhizococcus sp.
 Rhizococcus sp.

_____ (?)

Grypetes unicolor, Fitch.
 Ischnodemus falicus, Say.
 Westwoodia sp.
 Miris (?) affinis.

COLEOPTERA.

Carabidae.

Amara impuncticollis, Say.
 Amara angustata, Say.
 Amara carinata, Lec.
 Anisodactylus opaculus, Lec.
 Anisodactylus rusticus, Dej.
 Anisodactylus harrisii, Lec.
 Anisodactylus sericus, Harr.
 Anisodactylus discoideus, Dej.
 Anisodactylus baltimorensis, Say.
 Agonoderus pallipes, Fab.
 Agonoderus corna, Fab.
 Calanthus gregarius, Say.
 Galerita Janus, Fab.
 Harpalus herbivagus, Say.
 Harpalus calignosus.
 Harpalus pennsylvanicus, DeGeer.
 Lebia atriventris, Say.
 Patrobus longicornis, Say.
 Platnus limbatus, Say.

Pterostichus sayi, Brulle.
Pterostichus permundus, Say.
Pterostichus lucublandus, Say.

Coccinellidae.

Coccinella 9-notata, Hbst.
Megilla maculata, DeGeer.

Byrrhidae.

Byrrhus pilula.

Elateridae.

Cebrio bicolor, Fabr.

Scarabaeidae.

Allorhina nitida, Linn.
Cyclocephala immaculata, Oliv.
Lachnosterna pilosicollis.
Lachnosterna tristis, Fab.
Lachnosterna fraterna, Haw.
Lachnosterna Fusca, Froh.
Macroductylus subspinosus, Fab.

Chrysomelidae.

Chaetocnema pulicaria, Cr.
Dibola aerea.
Diabrotica 12-punctata.
Gastrophysa polygoni, Linn.
Maltica ignita, Ill.
Paria 6-notata, Say.
Systema taeniata.

Otiorynchidae.

Epicaerus imbricatus, Say.

Curculionidae.

Centrinus scutellum-album.
Centrinus picumanus, Hubst.

Pissodes strobi, Peck.
Phytonomus punctatus, Fab.

Calandridae.

Sphenophorus parvulus, Gyll.

Sphenophorus placidus, Say.
Sphenophorus scoparius, Horn.
Sphenophorus sculptilis, Uhl.
Sphenophorus carinosus, Oliv.
Sphenophorus robustus, Horn.
Sphenophorus pertinax, Oliv.
Sphenophorus ochreus, Lec.

DIPTERA.

Cecidomyiidae.

Cicidomyia destructor, Say.

Tipulidae.

Pachyrrhina sp.
Tipula bicornis.
Tipula tetrocephala, Lec.

Oscinidae.

Chlorophisca prolifica, O.S.
Meromyza americana, Fitch.
Oscinis Variabilis, Loew.
Oscinis dispar.

HYMENOPTERA.

Tenthredinidae.

Dolorus niger.
Dolorus collaris, Say.
Dolorus sericeus, Say.
Dolorus arvensis, Say.
Nematus marylandicus, Norton.

Uroceridae.

Cephus Occidentalis, R.& M.
Cephus pygmaeus,

Chalcididae.

Isosoma hordei, Harr.
Isosoma ellynii, F.

LEPIDOPTERA.

Nymphalidae.

Brenthis bellona, Harr.
Cercyonis alope, Fabr.
Cercyonis nephele, Scudd.
Cercyonis pegala, Fabr.
Cassia sosybius, Fabr.
Cassia eurytris, Scudd.
Enodia portlandica, Scudd.
Neonympha mitchellii, French.
Neonympha phociom, Westm-Hew.
Neonympha corneoius, Fabr.
Oeneis macounii, Edw.
Oeneis jutta, Hubn.
Oeneis semidea, Say.
Oeneis calaris, Scudd.
Satyrodes eurydice, Scudd.

Hesperiidae.

Amblyscirtes vialis, Scudd.
Amblyscirtes samoset, Scudd.
Ancyl oxitha numitor, Feld.
Anthemaster leomardus, Scudd.
Atrytone zabulon, Scudd.
Atrytone logan, Edw.
Atalopedes huron, Scudd.
Erynnis sassacus, Scudd.
Erynnis manitoba, Scudd.
Erynnis metea, Scudd.
Erynnis attalus, Edw.
Euphyes verma, Scudd.
Euphyes metacomet, Scudd.

Hylephila phylaeus, Dru.
Larema accius, Scudd.
Larema hianna, Scudd.
Limochores palatka, Edw.
Limochores manataaqua, Scudd.
Limochores pontiac, Scudd.
Limochores bimacula, Scudd.
Limochores taumas, Scudd.
Oligoria maculata, Scudd.
Pamphila mandan, Edw.
Phycanassa viator, Scudd.
Poanes massasoit, Scudd.
Polites peckius, Scudd.
Thymelicus aetna, Scudd.
Thymelicus mystic, Scudd.
Thymelicus brettus, Scudd.

Sphingidae.

Deilephila lineata, Fabr.

Ctenuchidae.

Ctenucha virginica, Charp.
Scepsis (?) edwardsii, Grote.
Scepsis fluvicollis, Hubn.

Arctiidae.

Arctia quenselii, Guier.
Arctia figurata, Drury.
Arctia achais, G. & R.
Arctia saundersii, Grote.
Arctia virgo, Linn.
Arctia nais, Drury.
Arctia celia, Saund.
Arctia decorata, Saund.
Arctia placentia, Abb-Sm.
Arctia remissa, Hy. Edws.
Arctia phalerata.
Arctia phyllira, Drury.
Arctia virguncula, Kirby.
Arctia brucei, Hy. Edw.
Arctia arge, Drury.
Arctia remissa, Hy. Edw.
Leucarctia acraea, Drury.

Liparidae.

Orgyia leucostigma, S. & A.

Noctuidae.

Adelphagrotis prasima, Fabr.
Agrotis ypsilon, Robt.
Apamea nictitans, Bkh. (European ?)
Carneades messoria, Harr.
Carneades scandens, Riley.
Carneades pitychrous, Grote.
Carneades tassellata, Harr.
Carneades insignata, Walk.
Carneades opipara, Morr.
Chytolita morbidalis, Guen.
Drasteria erectea, Craw.
Feltia jaculifera, Lint.
Feltia heriles, Grote.
Feltia malefida, Guen.
Feltia annexa, Tr.
Feltia gladiaria, Morr.
Feltia subgophica, Haw.
Gortyna nitela, Guen.
Gortyna cataphracta.
Hadena devastatrix, Brace.
Hadena stipata, Morr.
Heliophila pallens, Linn. (European ?)
Heliophila phragmiticola, Guen.
Heliophila albilenia, Hubn.
Heliophila pseudargyra, Guen.
Heleothis plogophagus, G. & R.
Heliothis armigera, Linn.
Laphygma furgiperda, S. & A.
Leucania unipuncta, Grote.
Nephelodes minians, Guen.
Nephelodes violans, Guen.
Noctua lubricans, Guen.
Noctua bicarnea, Guen.
Noctua clandestina, Harr.
Noctua pletca, Linn.
Noctua fennica, Tauch.
Noctua baja, Fabr.
Noctua c-nigrum, Linn.

Peridroma occulta, Hubn.
Peridroma saucia, Hubn.
Philometra serraticornis, Grote.
Plusia simplex,
Plusia contexta, Grote.
Pseudaglossa lubricalis, Guier.
Rhynchagrotis cupida, Grote.

Pyralidae.

Carabidae (on grasses.)
Crambus zaelus.
Crambus fascicostellus.
Crambus exsiccatus, Zeller.
Crambus vulgivagellus, Clem.
Diatraea sacchari, Guil.

Tortricidae.

Bactra lanceolana, Hubn.
Carpocapsa saltitans, Westwood.

Tineidae.

Coleophora viridicuprella, Wal. (Eu.)
Cycloplasis panicifoliella, Clem.

I N D E X .

INDEX.

Agropyrum caninum	131
" glaucum	129
" tenerum	126
Alopecurus pratensis	86
Andropogon provincialis	56
" scoparius	55
Appendix	i-xii
Aristida basiramea	77
Avena sativa	95
" fatua	95
Beckmania cruceaeformis	103
Beta vulgaris	40
Black fungi, Description of	14
Blight, Description of	12
Bouteloua racemosa	101
" oligostachya	99
Bromus schraderi	125
Bulbilis dactyloides	105
Calamagrostis confinis	93
" canadensis	91
" longifolia	93
Carex sp	51
" filifolia	50
Cenchrus tribuloides	51
Cercospora avicularis	43, 44
" beticola	41
" seminalis	106
" sorgi	59
" sp.	54, 56
Cinna arundinaceae	90
Cladosporium graminum	58, 62, 73, 75, 107, 109, 130, 140, 142
Claviseps purpurea	77, 128, 131, 132, 138, 140, 92, 92.
" nigricans?	46
Dactylis glomerata	115
Distichlis spicata	112
Etonia pennsylvanica	108
Eleocharis palustris	45
Elymus canadensis	138

Elvms striatus	141
" virginicus	136
Entyloma crastophyllum	73
Epichloe typhina	111, 131, 137.
" sp	65
Erysiphe communis	38, 40
" graminis	120, 117, 126, 123
Homalocenchrus oryzoides	74
Hordeum jubatum	133
Introduction	iii
Juncus tenuis	44
Koeleria cristata	109
Leaf Spots, Description of	25
Leptosphaeria sp	51
Lespedeza striata	37
List of Insects	i-xii
Macrosporium commune	37
Medicago sativa	35
Metasphaeria leersia	75
Mildews, Description of	11
" Treatment of	11
Muhlenbergia glomerata	85
" mexicana	83
Oryzopsis micrantha	82
Panicum capillare	62
" crus-galli	60
" clandestinum	64
" depauperatum	66
" virgatum	66
Phalaris arundinacea	75
Phragmites vulgaris	106
Phyllochora graminis	84, 89, 91, 114 137, 139
Plates	xii-
Pisum sativum	39
Poa alsodes	121
" caesia	122
" nemoralis	116

Poa pratensis	119
" serotina	117
" tenuifolia	124
Polythrincium trifolii	33
Polygonum avicularis	43
" erectum	41
Pseudopeziza medicaginis	36
Puccinia andropogi	55,57
" coronata	95,104
" carices	51,51
" emaculata	63,67
" graminis	87,91,94,95
98,110,116,124,127,130,132,132,134,139	
" maidis	54
" n.sp.	83,113
" obtecta	48,49
" phragmites	98,107
" rubigo-vera	95,108,118,
121,128,133,135,138,139	
" schedonardi	99
" stipae	80,81
" striatula	76
" sp	141
" sporoboli	90
" vexans	88,100,102
Rusts, Description of	16
" Treatment of	20
Setaria italica	70
" viridis	68 68
Sclerospora graminicola	69,71
Schedonardus paniculatus	98 98
Scirpus lacustris	47
" fluviatilis	46
" pungens	49
Smuts, Description of	22
" Treatment of	23
Sorghum halapense	58
Sorosporium ellisii	58

Sorosporium syntherismae	63
Spartina cynosuroides	97
Sporobolus cryptandrus	89
" cuspidatus	87
Stipa spartea	80
" viridula	79
Summary	144
Tilletia fetens	133
Trifolium hybridum	34
" incarnatum	31
" medium	30
" pratense	29
" repens	32
Triticum vulgare	132
Uromyces trifolii	30, 31, 32, 34
" polygoni	42, 43
" junci	
" dactylidis	120
" graminicola	
" scirpi	47
Vermicularia denudata	120
Zea mays	53
Zizania aquatica	72

~~~~~



PLATES WITH EXPLANATIONS.

Plate I.

PUCCINIA GRAMINIS, PERS.

All but the first stage of the common wheat rust.

- 1, longitudinal section of leaf sheath showing the sori.
- 2, the same highly magnified.
- 3, longitudinal section of *Æcidium* cup on Barberry, showing the arrangement of the aecidiospores.
- 4, aecidiospores highly magnified.
- 5, epithelial cells of aecidium cup highly magnified.
- 6, uredospore of *Puccinia graminis* on wheat.
- 7, cross section through a sorus.
- 8, teleutospore of *Puccinia graminis* on wheat.

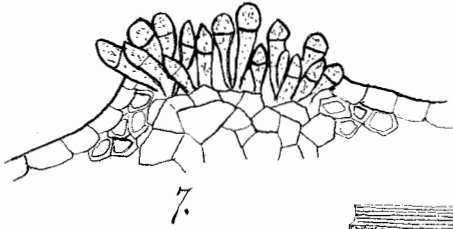

7.

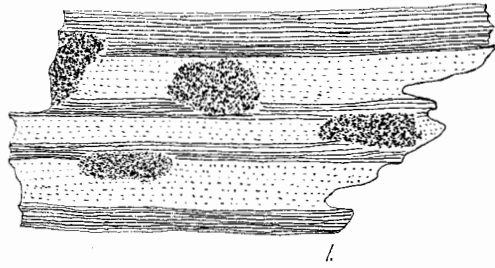

1.

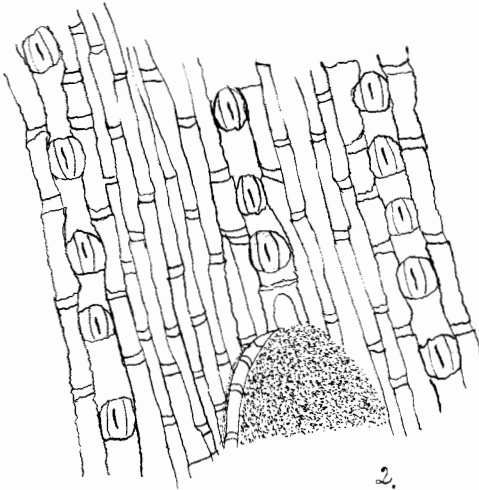

2.



4.

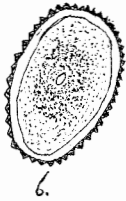

6.

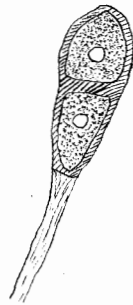

8.

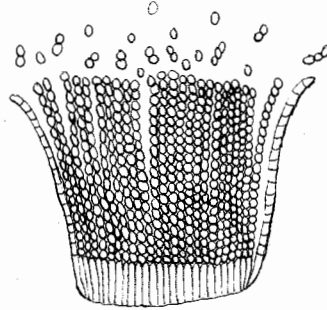

3.

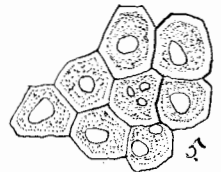

5.

Plate II.

Teleuto- and uredospores of various species  
of Puccinia.

- 1, teleutospore of *P. phragmites* on *Phragmites vulgaris*.
- 2, teleutospore of *P. n.sp.* on *Oryzopsis micrantha*.
- 3, teleutospore of *P. graminis* on *Hordeum jubatum*.
- 4, teleutospore of *P. emaculata* on *Panicum virgatum*.
- 5, uredospore of *P. emaculata* on *Panicum virgatum*.
- 6, teleutospore of *P. maydis* on *Zea mays*.
- 7, teleutospore of *P. graminis* on *Poa tenuifolia*.
- 8, teleutospore of *P. schedonardi* on *Schedonardus texans*.
- 9 & 10, teleutospores of *P. n.sp.* on *Distichlis spicata* var.
- 11, one-celled teleutospore of *P. vexans* on *Bouteloua racemosa*.

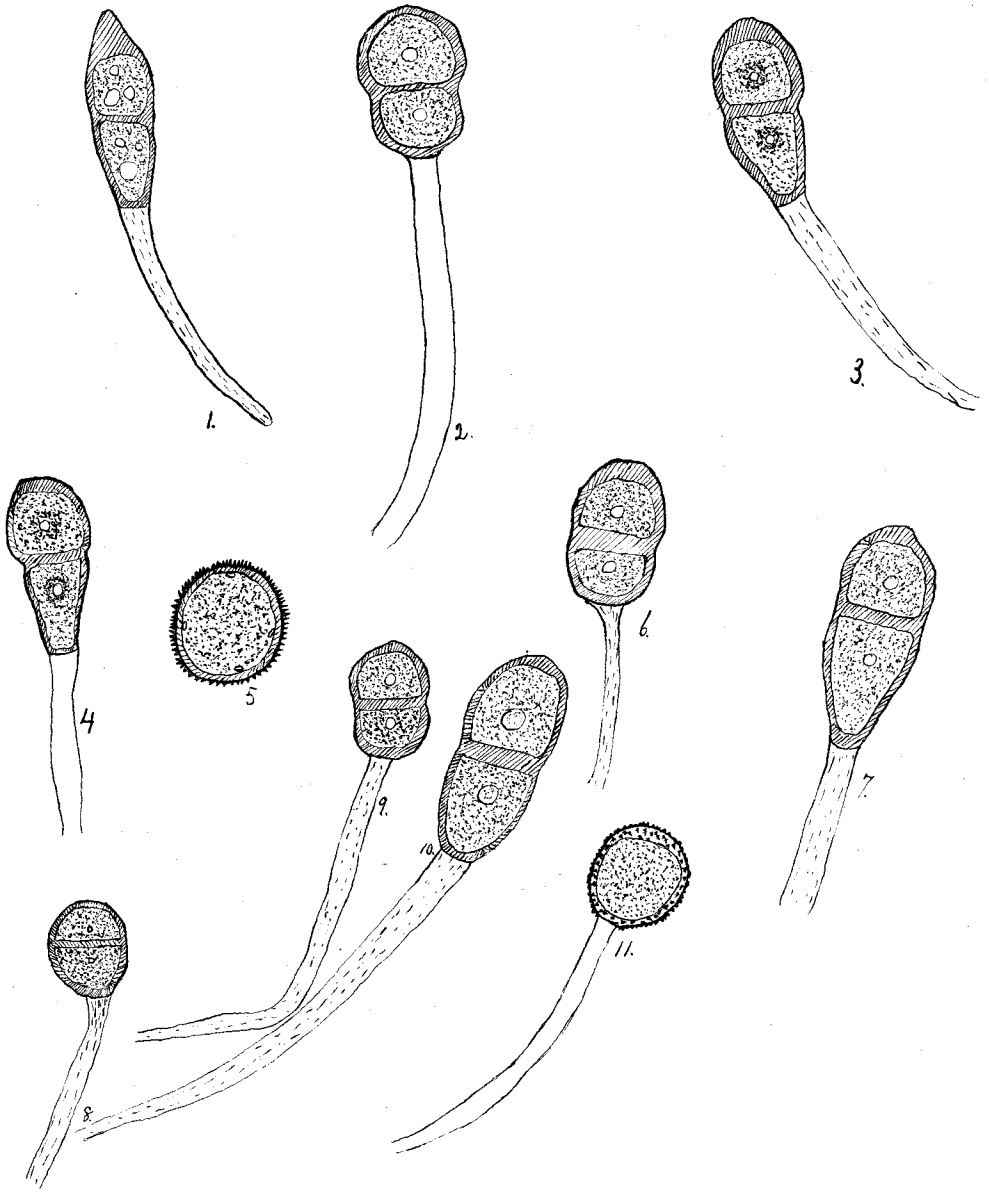

Plate III.

POLYTHRINCIUM TRIFOLII, KUNZE.

Showing the method of attack and the characteristics of the fungus.

- 1, under side of a leaf of *Trifolium repens* showing the stromae.
- 2, cross section of the same with the hyphae attached.
- 3, Hypha highly magnified.
- 4, conidia highly magnified.

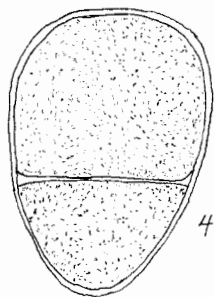
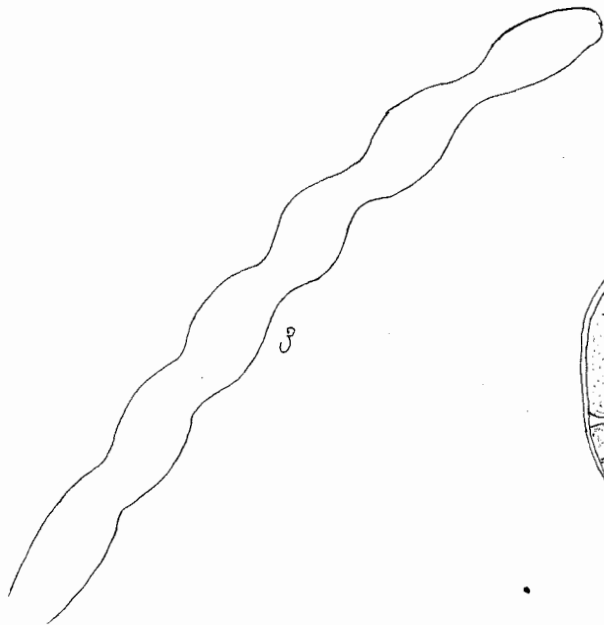
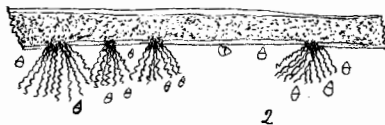
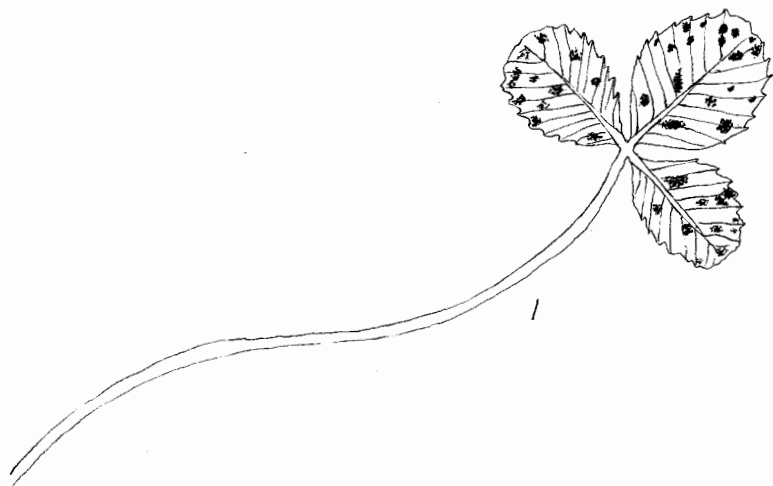

Plate IV.

MACROSPORIUM COMMUNE, RABH.

The vegetative portion of the fungus which developed of *Medicago sativa* in a moist chamber.

1, long branched and septate hypha.

2 & 3, spores beginning to develop.



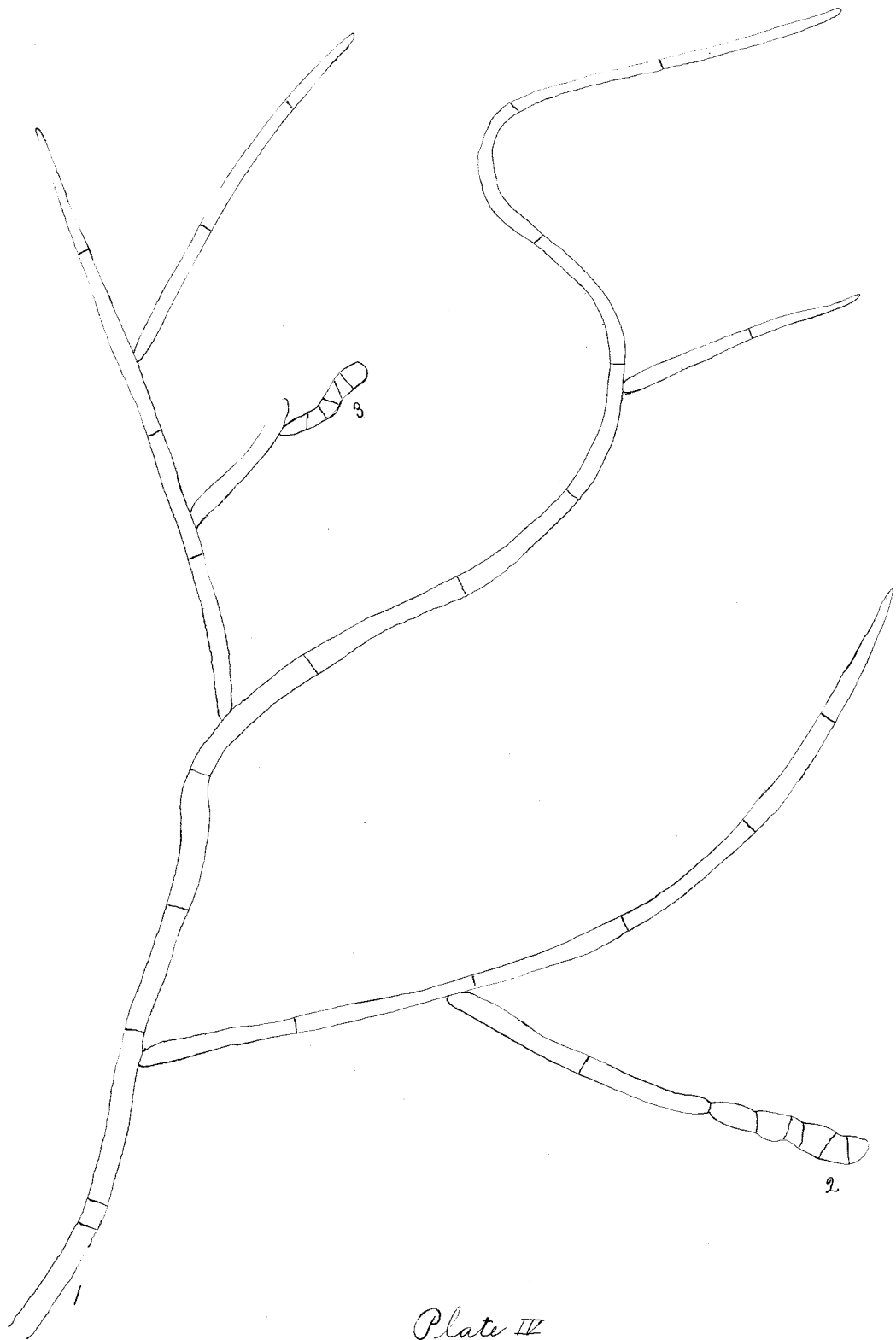

Plate IV

Plate V.

MACROSPORIUM COMMUNE, RABH.

Fully developed spores of hyphae shown in  
Plate IV.

- 1, young, small spore.
- 2, fully developed spore, normal.
- 3, fully developed spore germinating.
- 4, fully developed spore drawn to show the minute projections which occur on all of them.

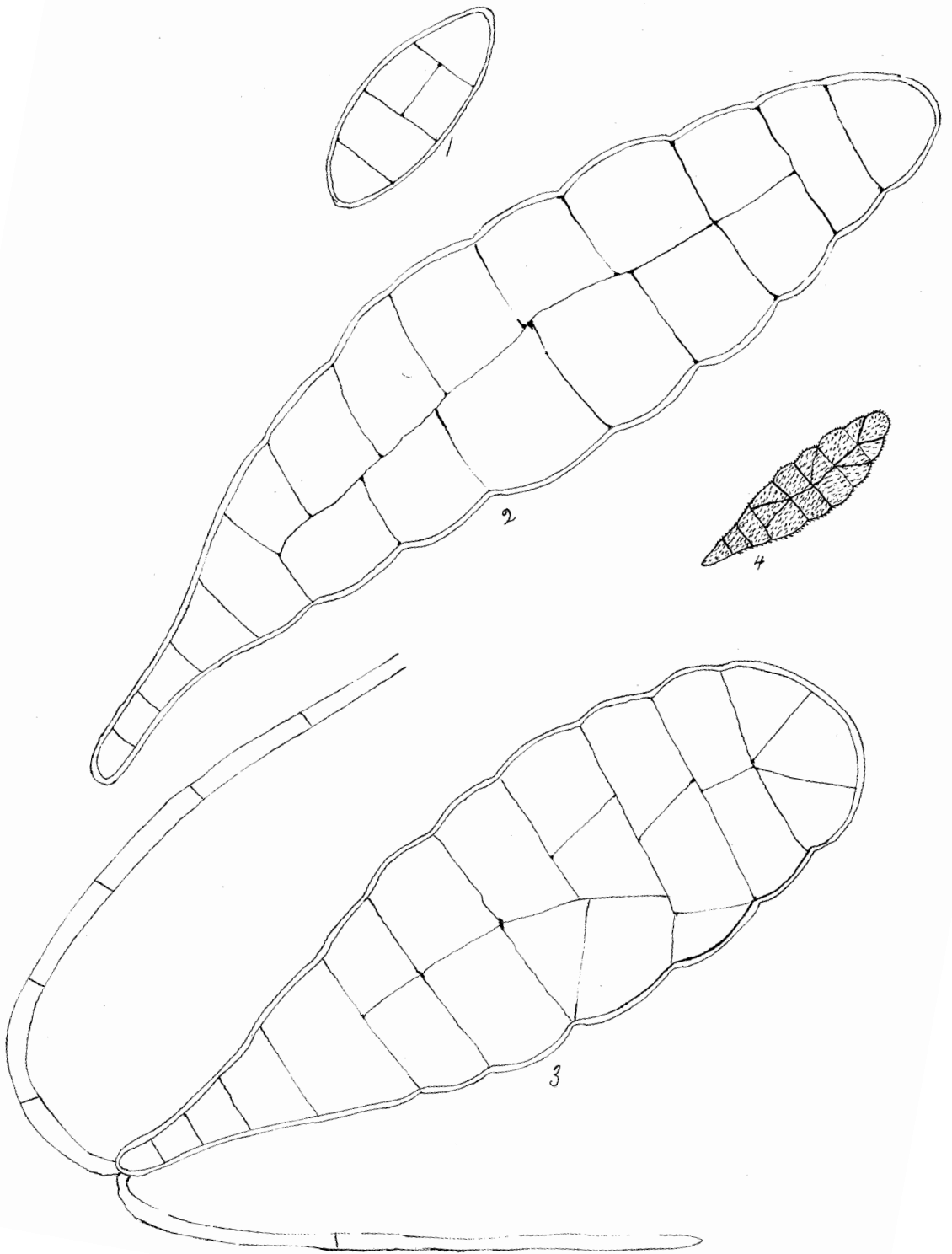

Plate IV

Plate VI.

PSEUDOPEZIZA MEDICAGINIS, (LIB.) SACC.

Showing method of attack and the general characteristics of the fungus on *Medicago sativa*.

- 1, leaf, showing the dark brown spots which surround the sporocarp.
- 2, cross section of a leaf, (not correctly drawn).
- 3 & 4, asci with included conidia.
- 5, cross section of a sporocarp, (correctly drawn).

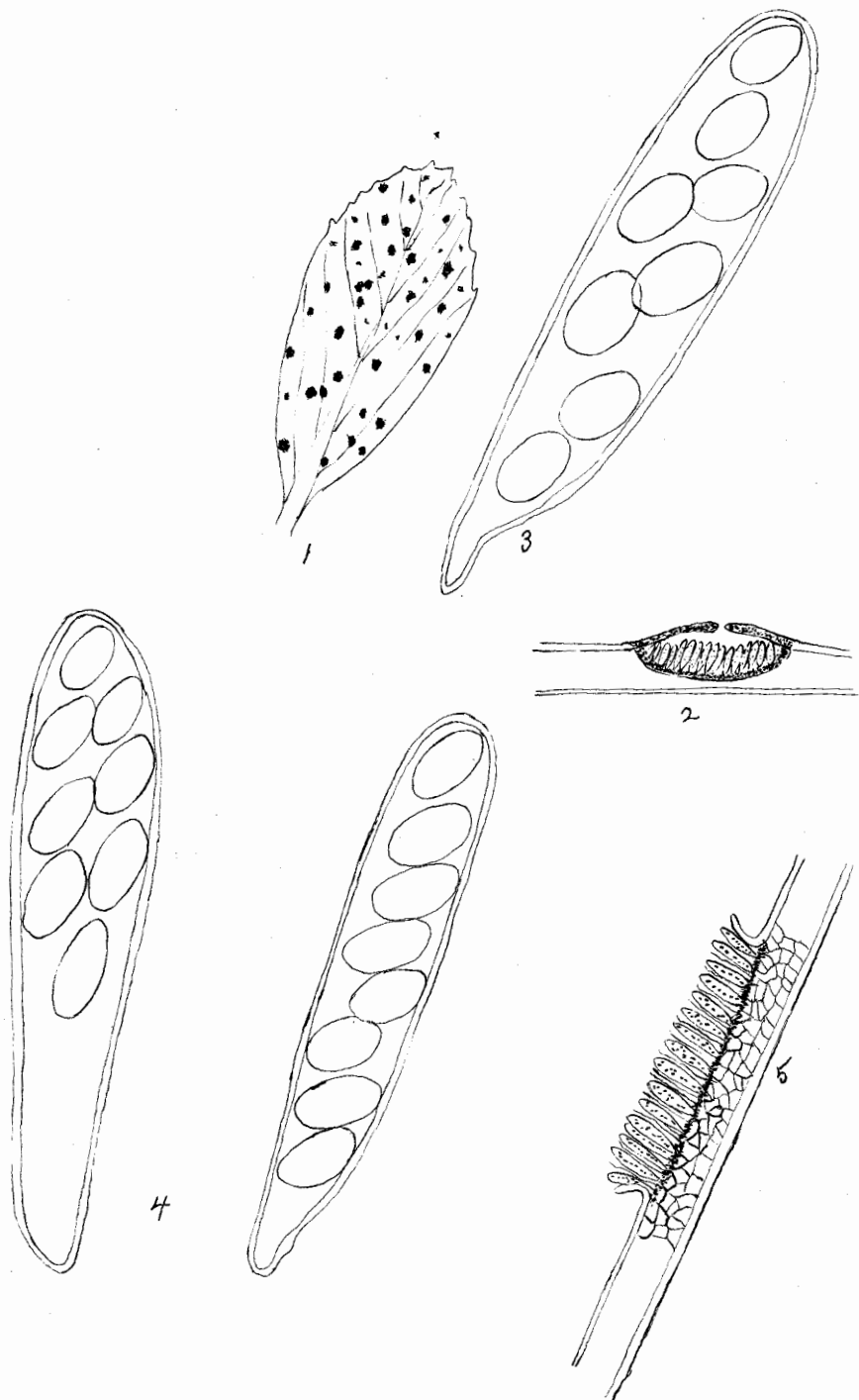

Plate VI

Plate VII.

ERYSIPHE COMMUNIS, (WALLR.) FR.

Illustrating perithecia, asci, conidia and hyphae on leaves and stems of *Pisum sativum*.

- 1, perithecia with hyphae and appendages.
- 2, ruptured perithecium with escaping asci.
- 3, ascus with included sporidia.
- 4, single sporidium.

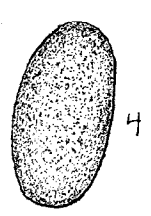
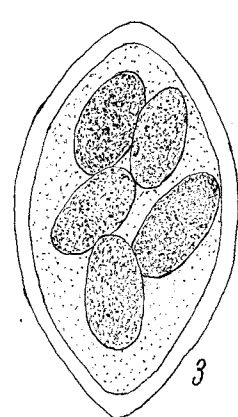
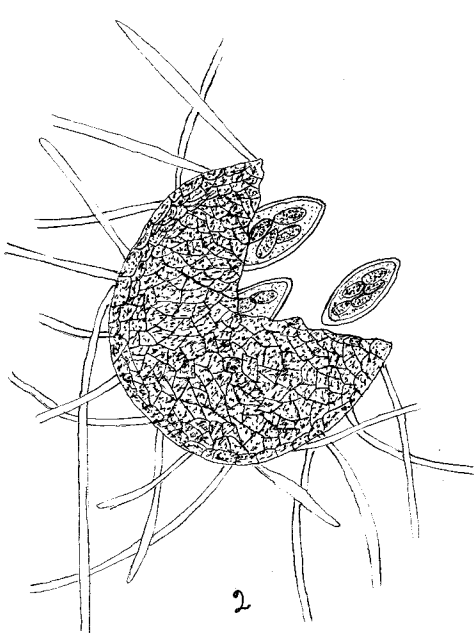
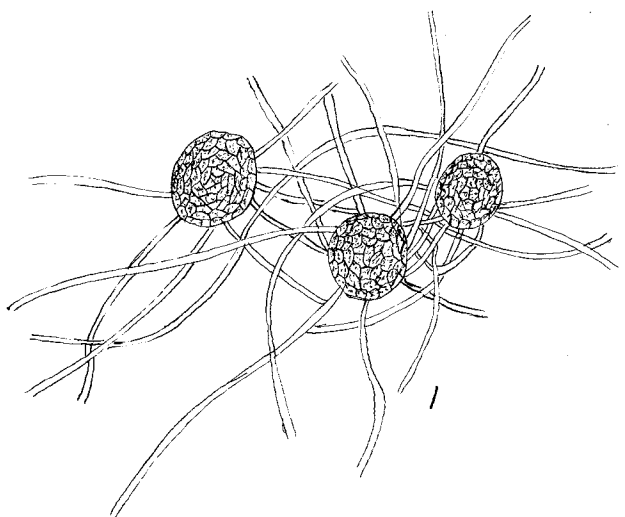

Plate VII

Plate VIII.

CERCOSPORA BETICOLA, SACC.

Showing the method of attack and general characteristics of the fungus on Beta vulgaris.

- 1, portion of leaf showing the brown, scarious spots.
- 2, cross section of a spot showing the hyphae and attached conidia.
- 3 & 4, conidia highly magnified.



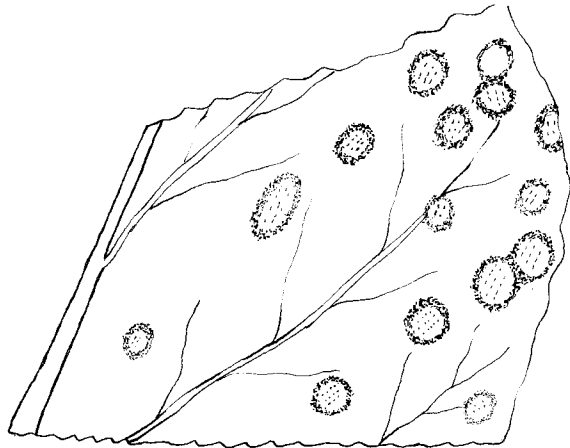

1

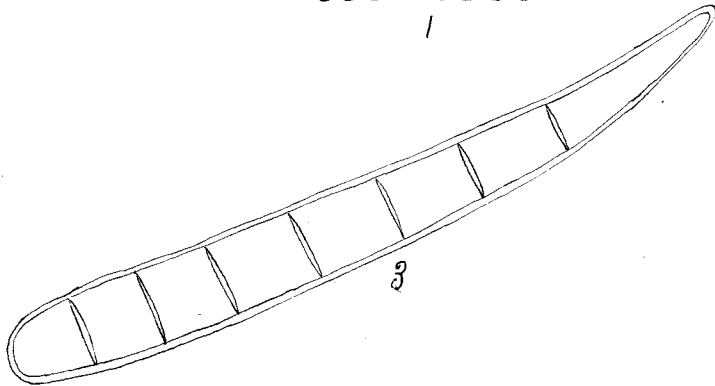

3

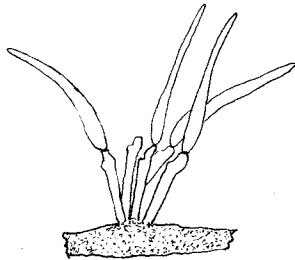

2

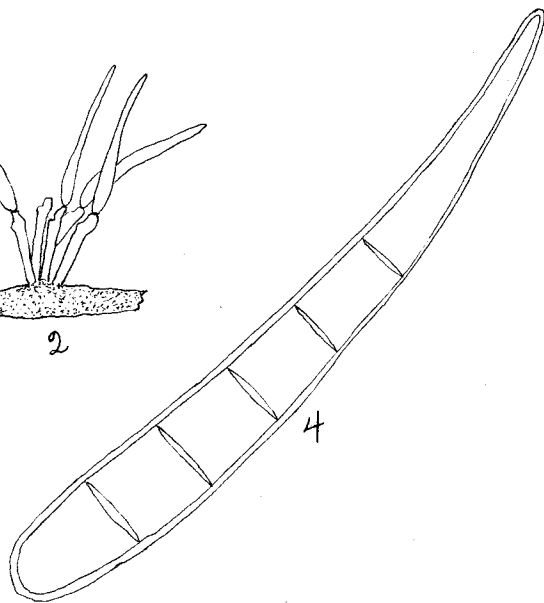

4

Plate IX.

UROMYCES POLYGONI, (PERS.) FCKL.

Showing spores found on Polygonium erectum and  
P. aviculare.

1, 2 & 3, long, pediceled teleutospore.

4, echinulate uredo-spore.

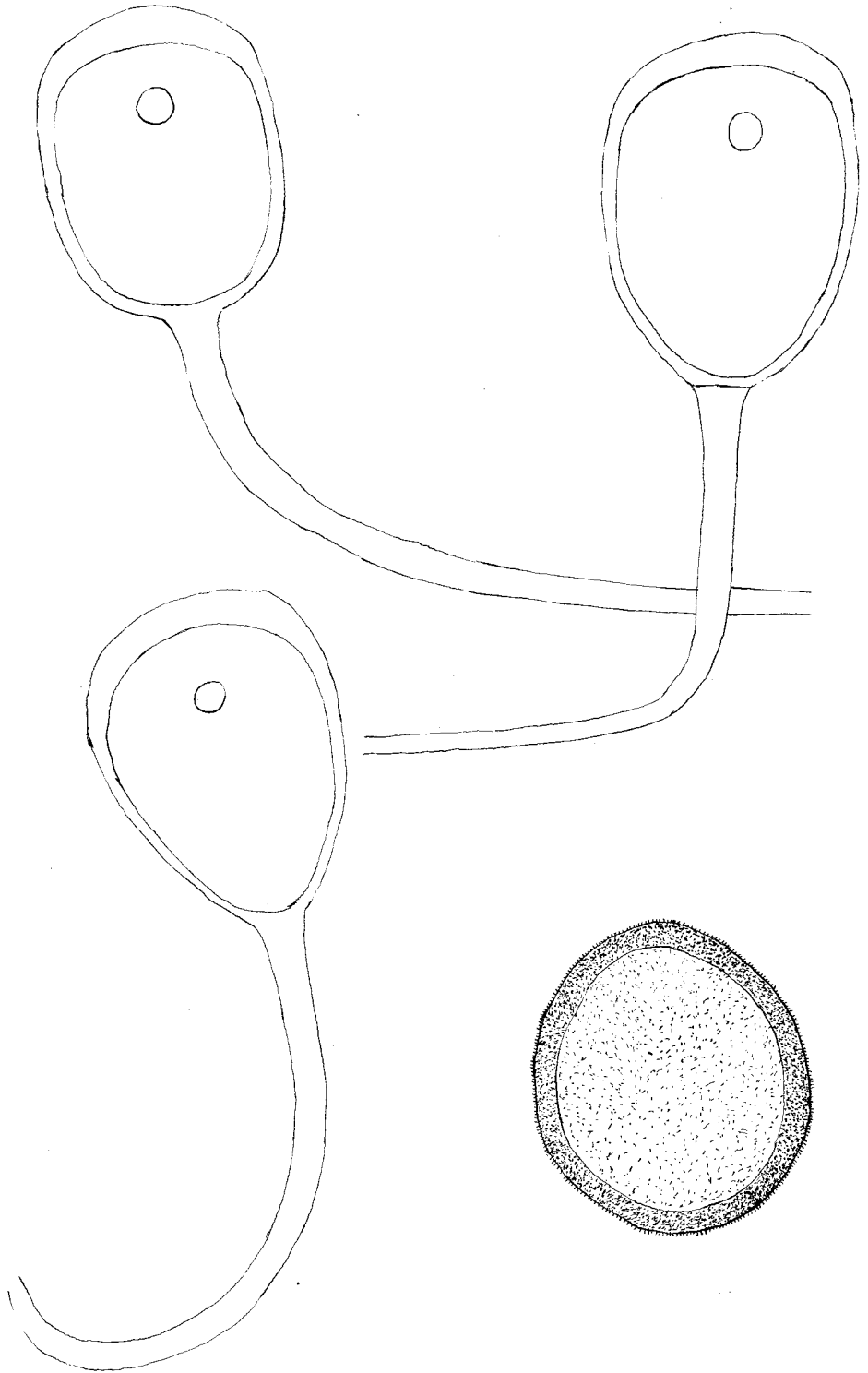

Plate IX

Plate X.

CERCOSPORA AVICULARIS, WINT.

Showing general characteristics and method of attack on leaves of *Polygonium erectum*.

- 1, leaf, showing the brown, purple-margined spots.
- 2, cross section of one of the spots with hyphae attached.
- 3,4,5 & 6, conidia highly magnified.
- 7 & 8, hyphae highly magnified.

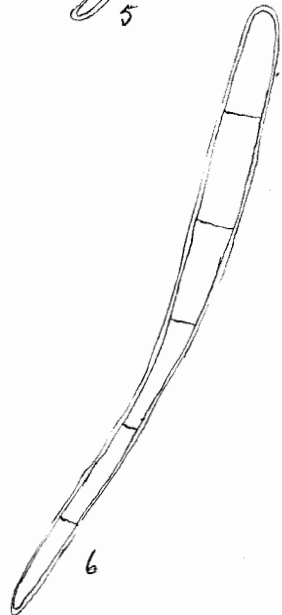
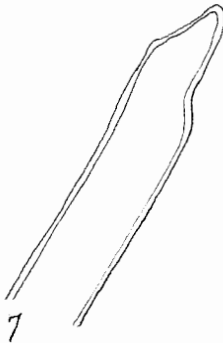
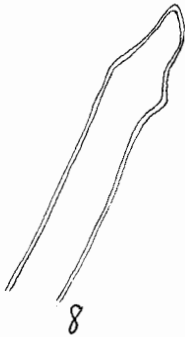
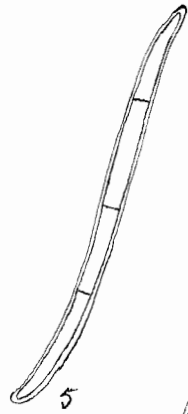
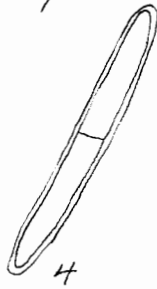
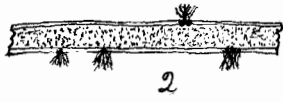

Plate XI.

UROMYCES JUNCI, (SCHUM.) TUL.

Showing diversity of teleutospores on the rust  
on *Juncus tenuis*.

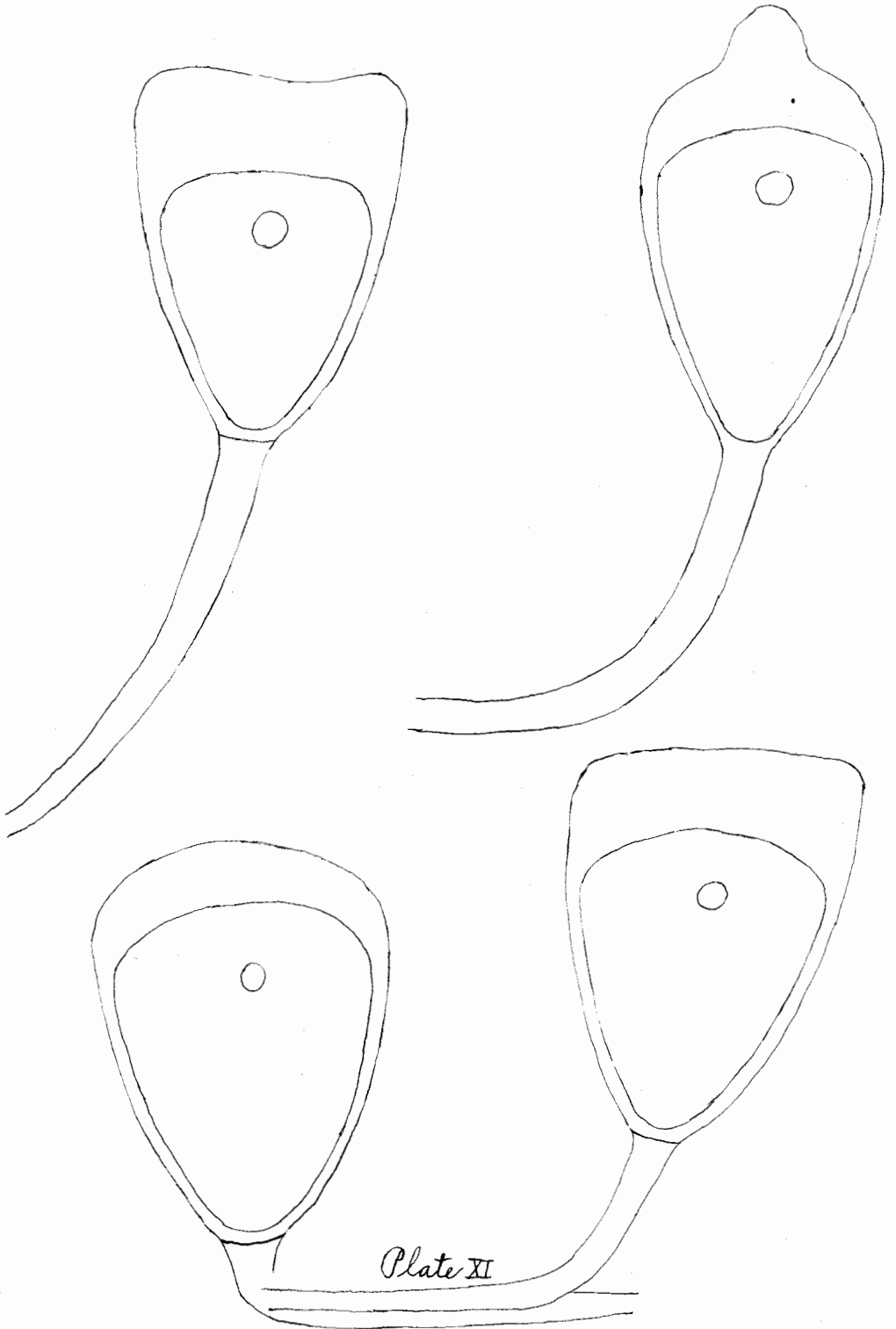

Plate XI

Plate XII.

UROMYCES SCIRPI, BURRILL.

Showing variation in forms of teleutospores on  
Scirpus fluviatilis.



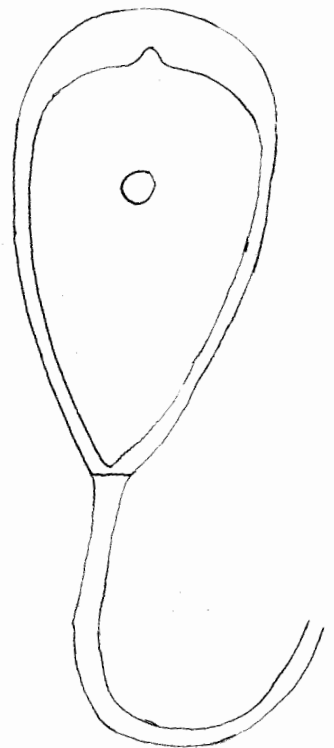
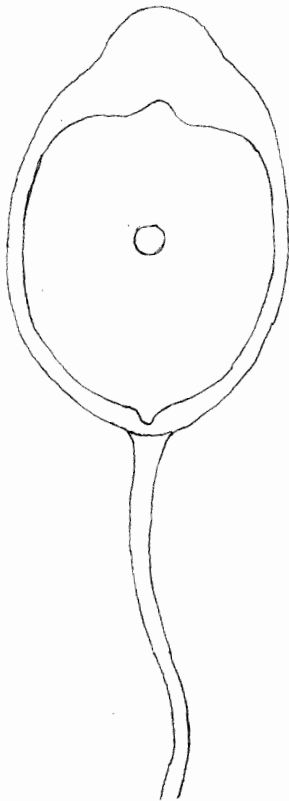
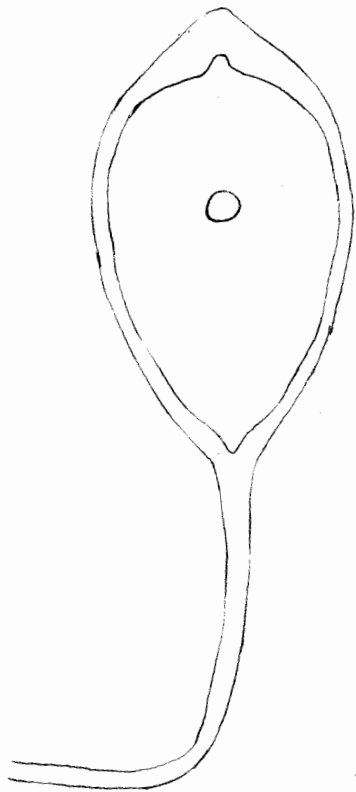
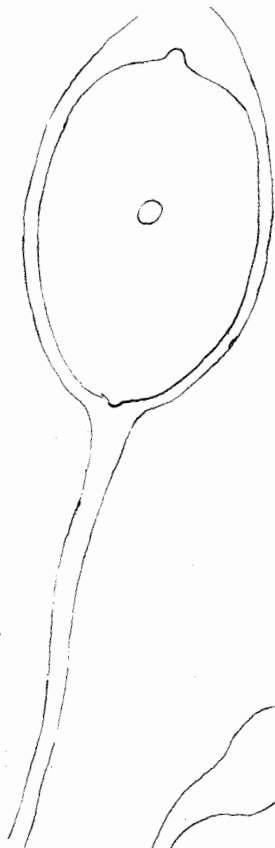

Plate XIII.

Puccinia obtecta, Peck.

Showing variation in forms of teleutospores on  
on Scirpus lacustris.

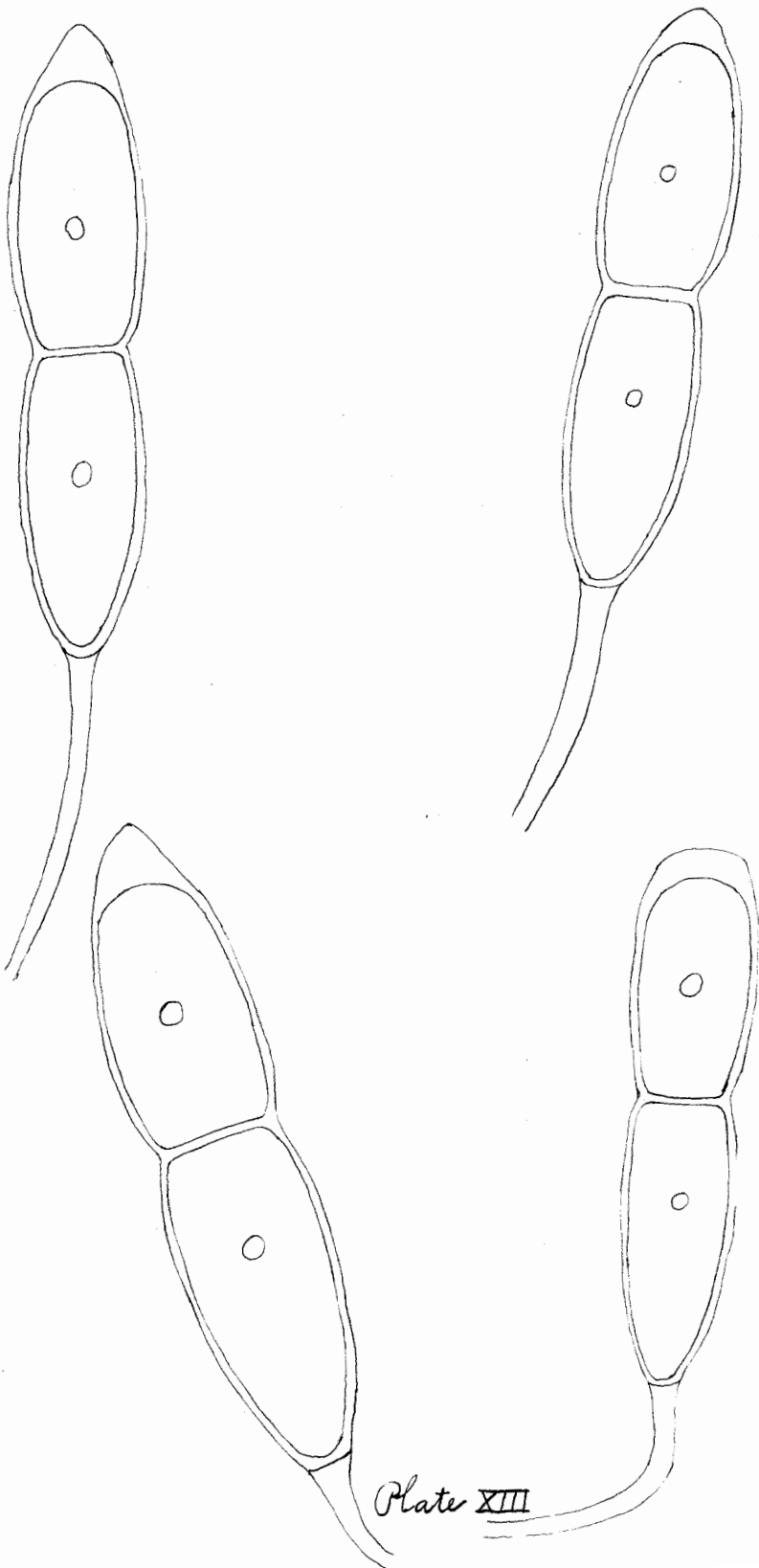

Plate XIII

Plate XIV.

Puccinia caricis, (Schum.) Rebent.

Showing forms of teleutospores on Carex sp.

1, 2, & 3, teleutospores with no nuclear spots.

4, teleutospores with nuclear spots.

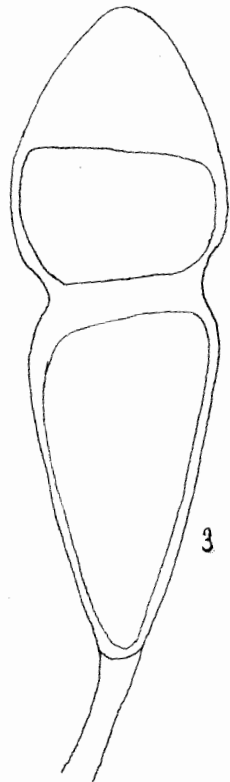
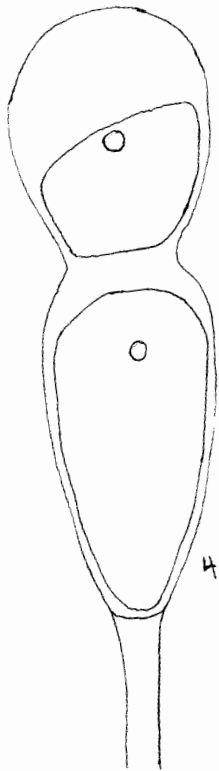
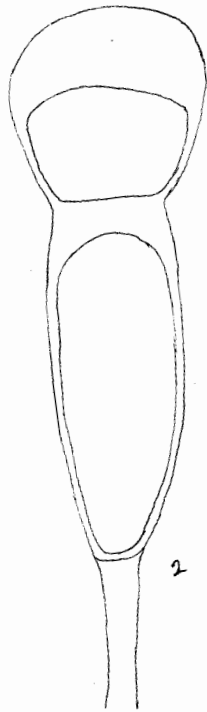
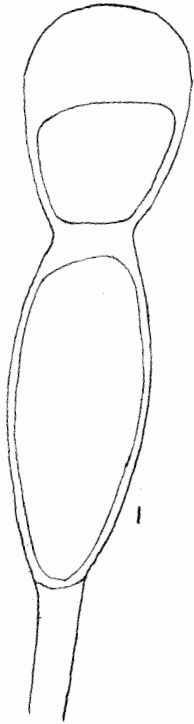

Plate XV.

PUCCINIA MAYDIS, CARRADORI,

USTILAGO MAYDIS, D.C.

Showing the teleutospores of the rust and the smut on Zea mays.

1 & 2, teleutospores of P. maydis.

3,4,&5, teleutospores of U. Maydis.

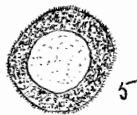
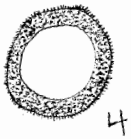
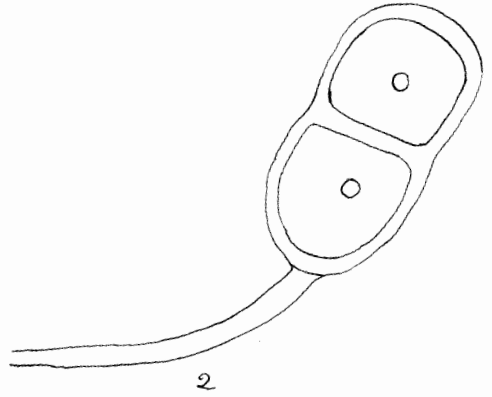
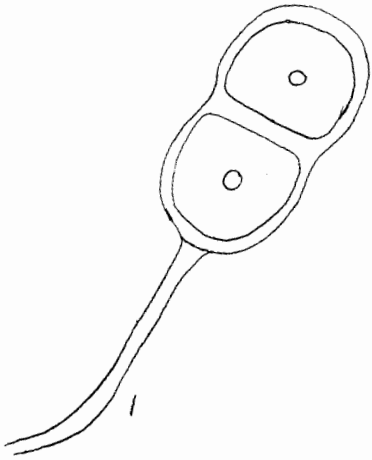

Plate XVI.

Puccinia andropogi, Schw.

S and  
Sporidium ellisii, Wint.

Showing the teleutospores of the rust and smut  
on *Andropogon provincialis*.

1-3, teleutospores of the rust.

4&5, teleutospores of the smut.



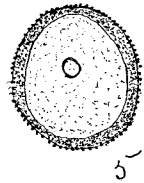
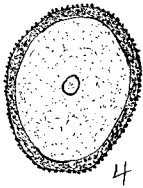
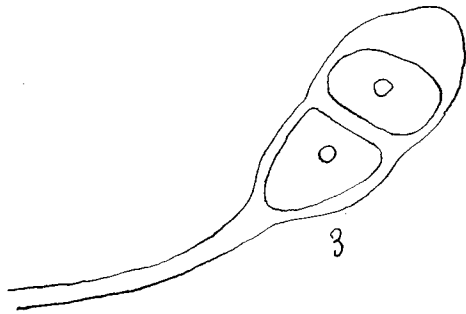
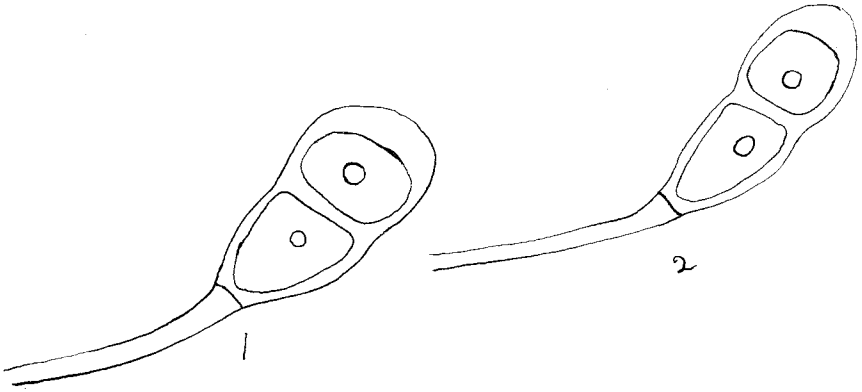
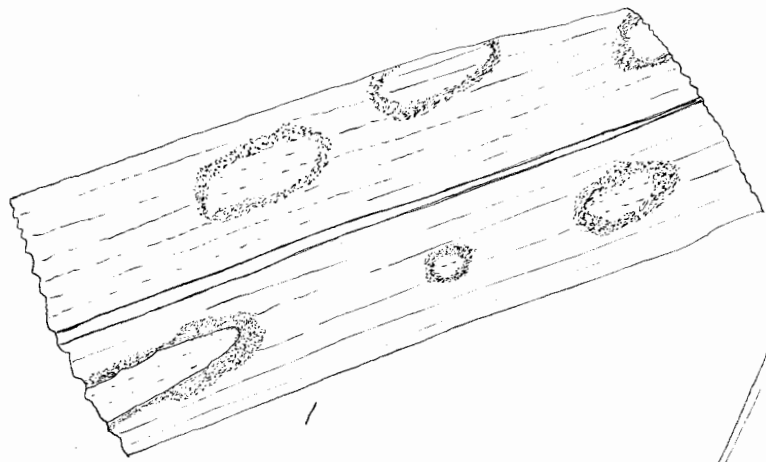

Plate XVII.

CERCOSPORA SORGI, E. & E.

Showing method of attack and characteristics  
of this fungus on Sorghum halapense.

- 1, portion of leaf, showing the large purple-  
margined blotches and streaks.
- 2, Cross section of a blotch showing hyphae.
- 3, hypha highly magnified.
- 4-6, conidia highly magnified.
- 6-7, Macrosporium spores:



1

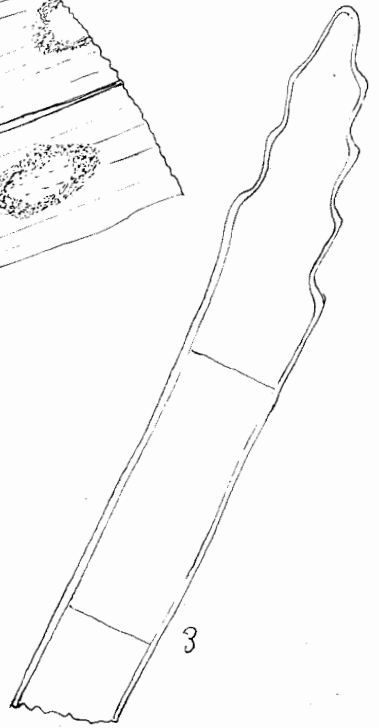

3

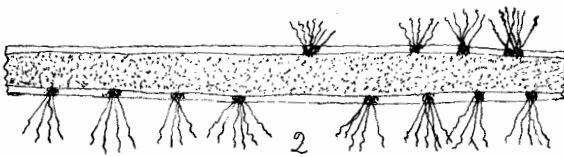

2



5

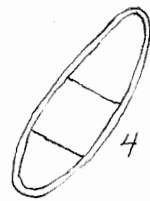

4

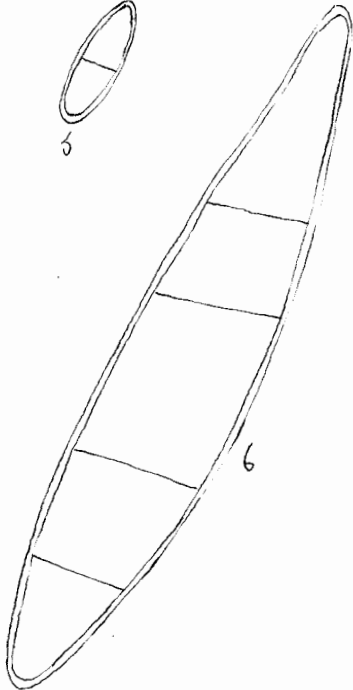

6

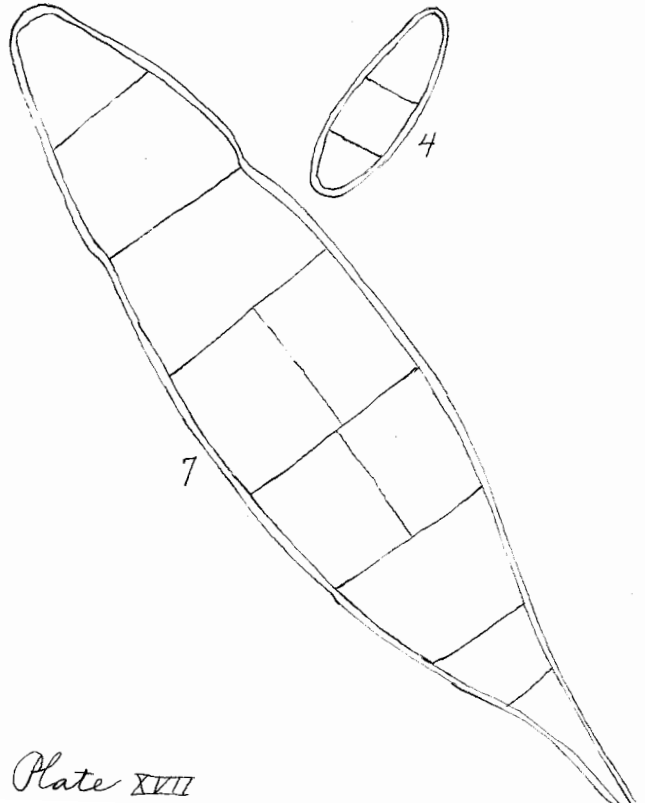

7

Plate XVIII.

CERCOSPORA     sp.

Showing the method of attack and general characteristics of the fungus on *Panicum clandestinum*.

- 1, leaf showing the brown scarious spots
- 2, hyphae highly magnified.
- 3-6, conidia highly magnified.

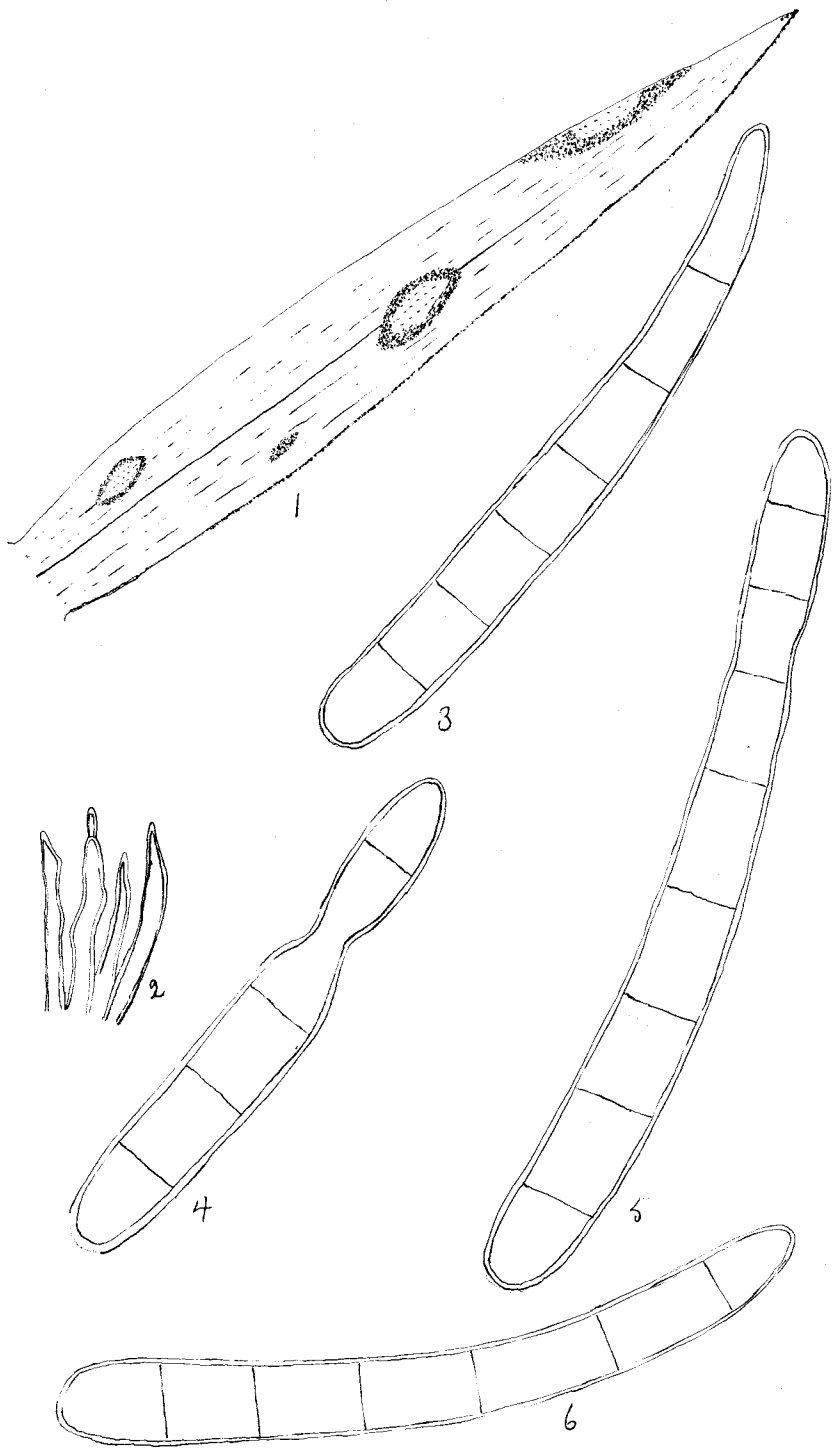

Plate XIX.

EPICHLÖE sp.

Showing method of attack and characteristics as far as they have been observed on *Panicum clandestinum*.

- 1, a single plant showing stroma on culm.
- 2, cross section of stroma showing the dense mass of hyphae.
- 3-7, conidia highly magnified.



Plate XIX

Plate XX.

UROMYCES GRAMINICOLA, BURRILL.

Showing teleutospore characteristics on *Panicum  
virgatum*.



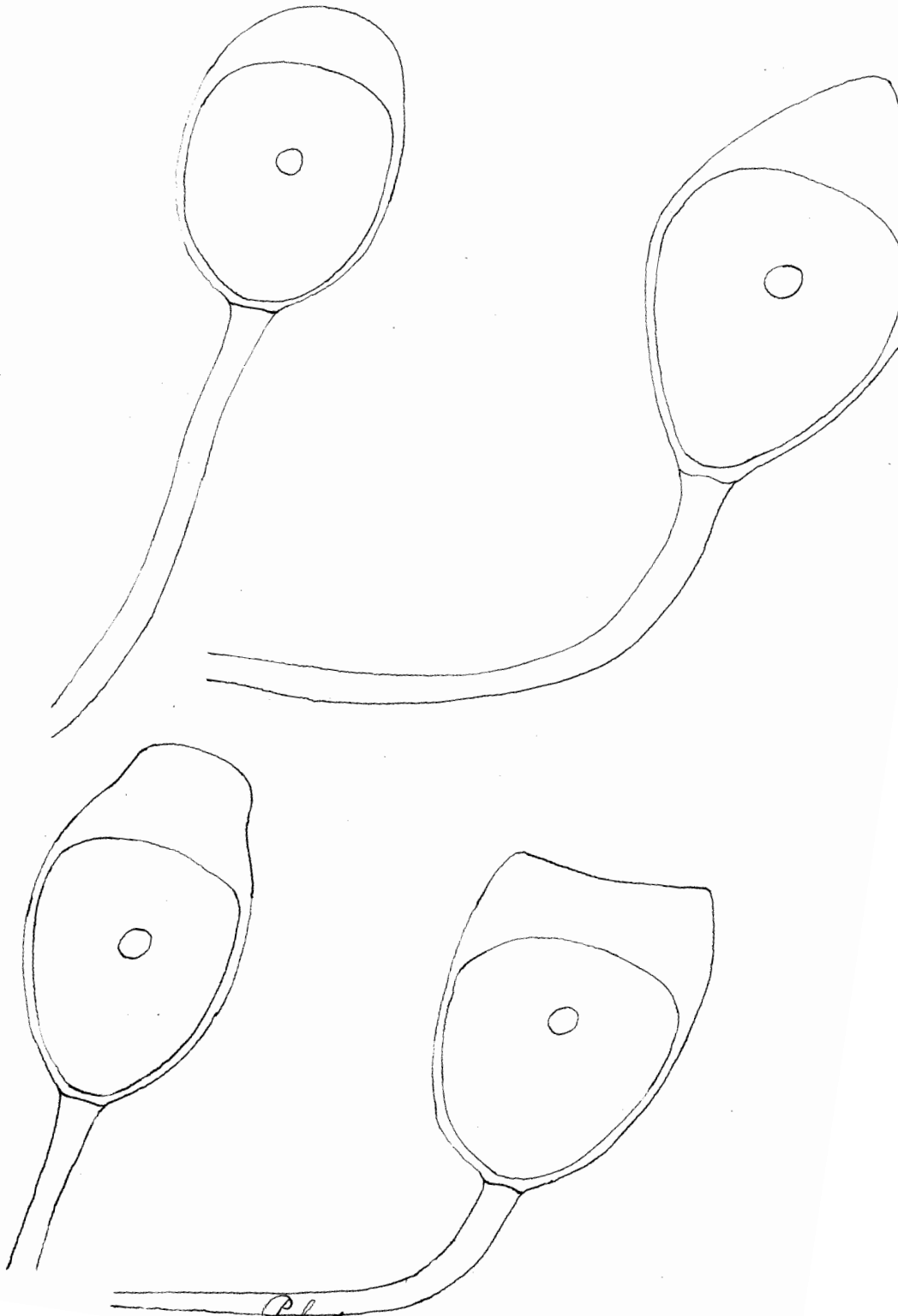

Plate XX

Plate XXI.

SCLEROSPORA GRAMINICOLA, (SACC.) SCHROET.

Showing characteristics of the different stages of growth on *Setaria* spp.

- 1 & 2, hyphae with developing conidia on *S. italica*.
- 3, conidium highly magnified.
- 4, oöspore on *S. viridis*.
5. ruptured oöspore.
6. escaping endospore.

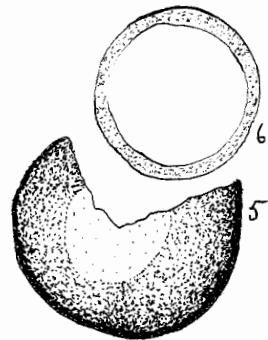
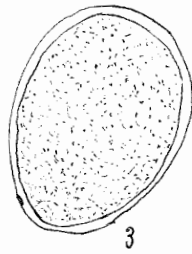
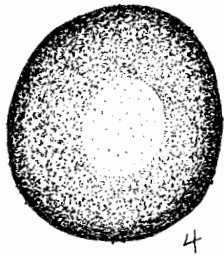
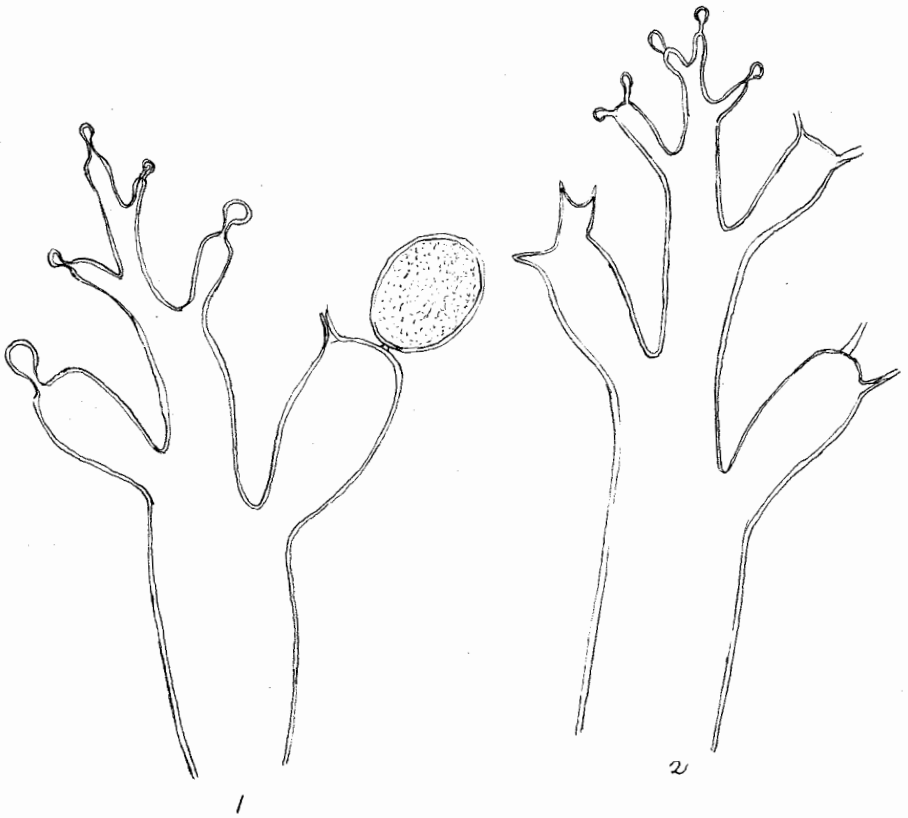

Plate XXII.

ENTYLOMA CRASTOPHILUM, SACC.

Showing the method of attack and the general characteristics of the smut on *Zizania aquatica*.

- 1, portion of sheath showing th long, dark streaks.
- 2, portion of culm showing the black, shining blotches.
- 3 & 4, teleutospores.
- 5, teleutospores as they appear in the sorus.
- 6, teleutospore with a short pedicel.

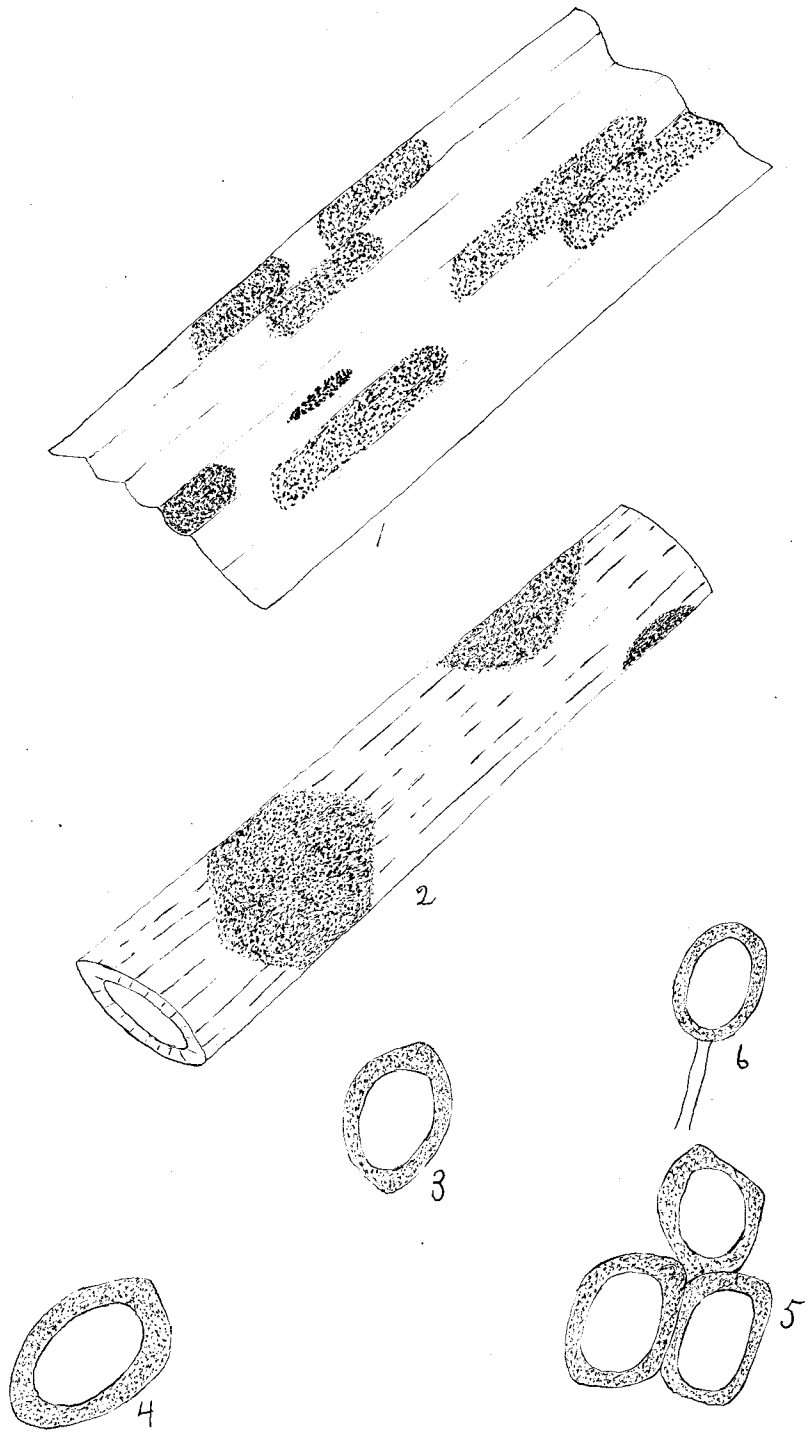

Plate XXII

Plate XXIII.

CLADOSPORIUM GRAMINUM,      CORDA.

Showing habits and characteristics of the  
fungus on *Homalocenchrus oryzoides*.

- 1, section of leaf showing hyphae.
- 2, hypha with attached conidia.
- 3-7, various forms of conidia.

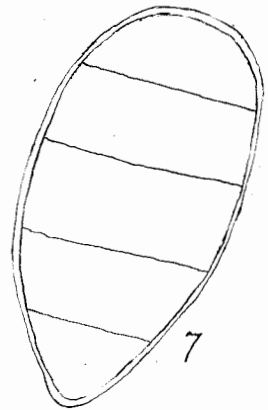
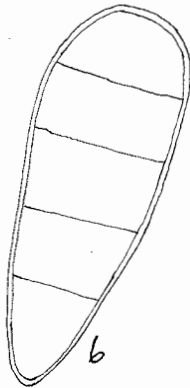
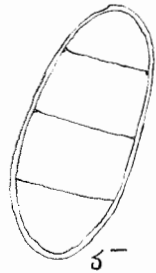
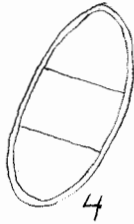
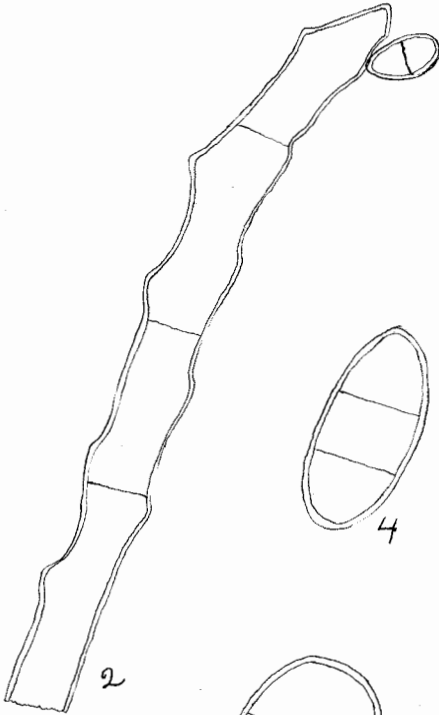
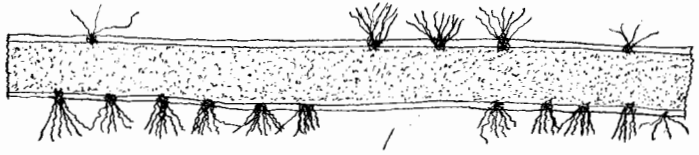

Plate XXIV.

METASPHERIA LEERSIA, (PASS.) SACC.

Showing method of growth and general characteristics on *Homalocenchrus oryzoides*.

- 1, portion of leaf with perithecia.
- 2, perithecium magnified.
- 3-6, asci with included sporidia.
- 7-9, sporidia highly magnified.



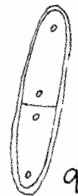
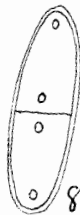
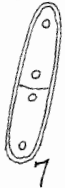
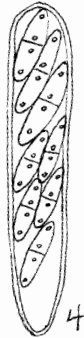
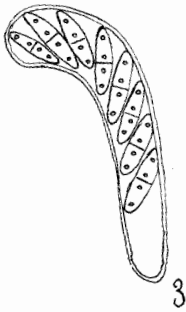
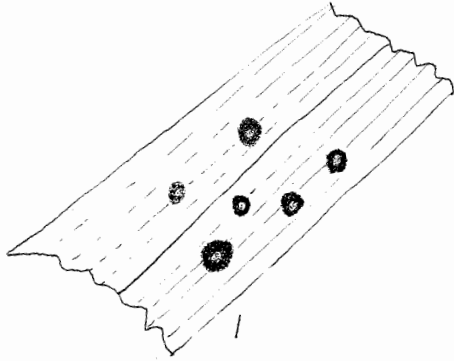

Plate XXV.

Puccinia striatula, Peck.

Showing various forms of teleutospores on  
Phalaris arundinacea.

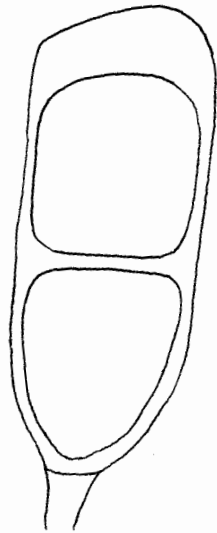
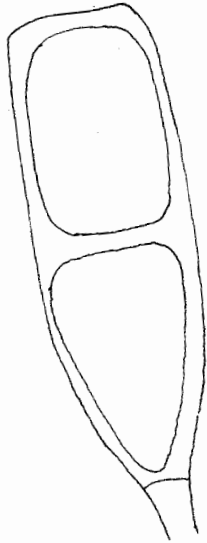
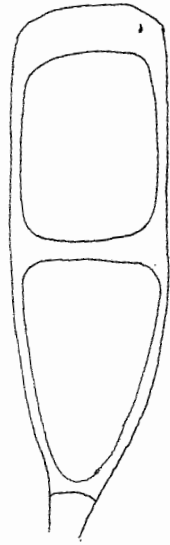
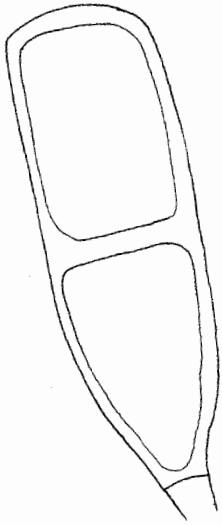

Plate XXVI.

S M U T   S P O R E S .

Showing some of the characteristics of five species of the order Ustilagineae.

1-3, teleutospores of *Ustilago aristidae*, Peck. On *Aristida basiramea*.

4-7, teleutospores of *Ustilago hypodytes*, (Schlect) Fr. On *Stipa viridula*.

8-11, teleutospores of *Ustilago syntherismae*, Schw. On *Cenchrus tribuloides*.

12-14, teleutospores of *Ustilago segetum*, (Bull.) Dittm. On oats.

15, Wheat berry distorted with teleutospores of *Tilletia faetens*. (E&C) Trel.

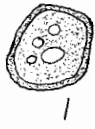

1

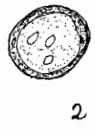

2

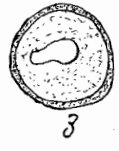

3



4



5



6



7



8



9



10



11



12



13



14

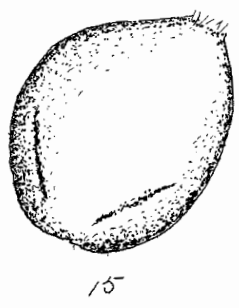

15

Plate XXVII.

Puccinia vexans, FARLOW.

Showing various forms of teleutospores on  
Sporobolus cuspidatus.

1,2&4, two-celled teleutospores.

3, one-celled teleutospore.

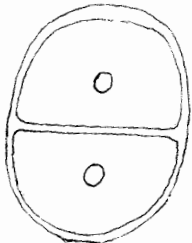

1

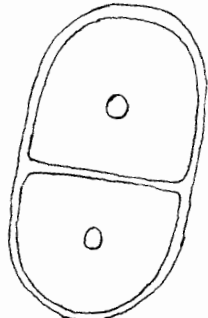

2

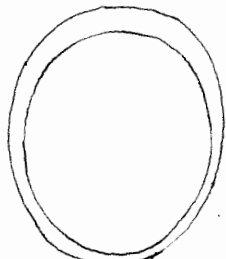

3

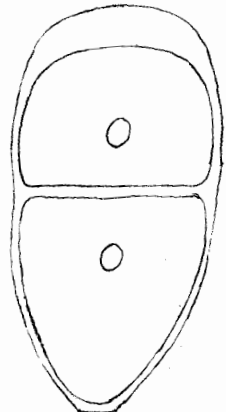

4

Plate XXVIII.

Puccinia Sporoboli, (?) Arthur.

Showing various forms of the one-celled teleuto-  
spores on Sporobolus cryptandrus.



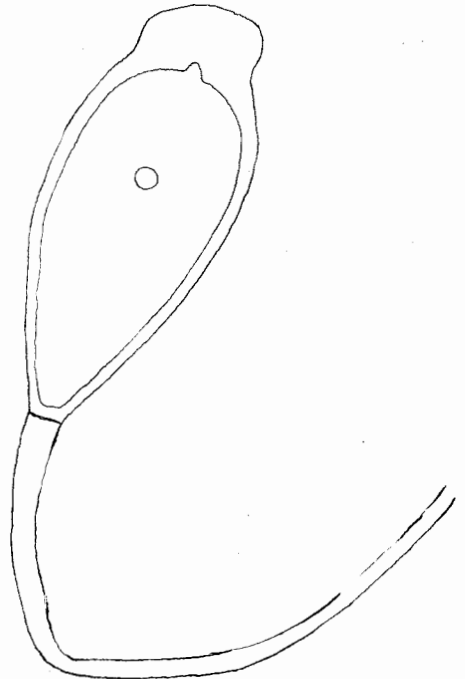
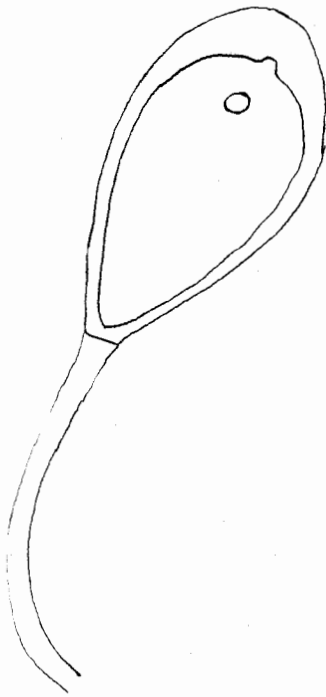
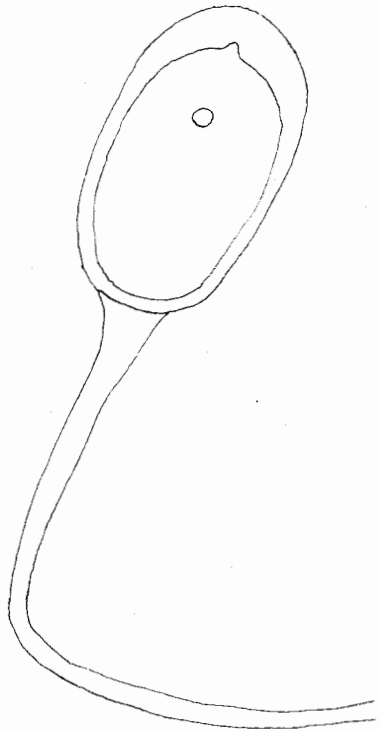
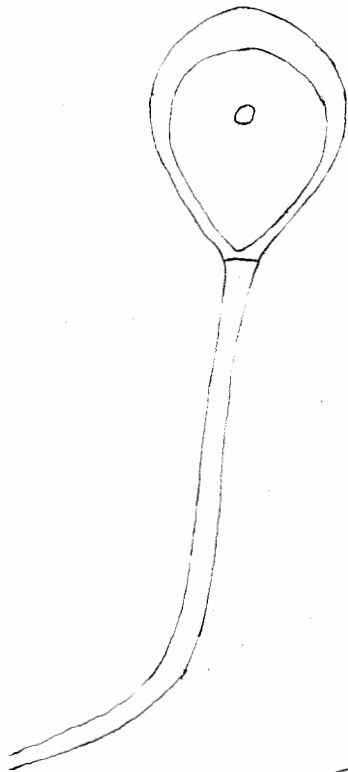
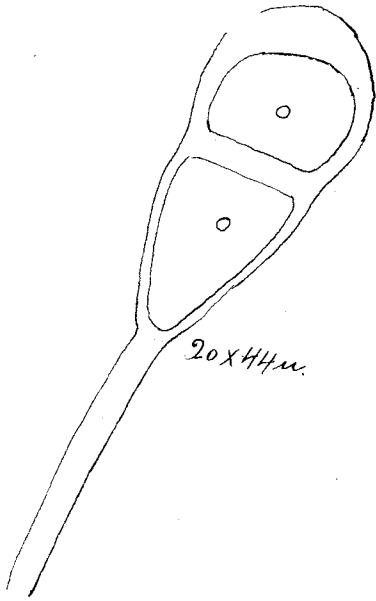

Plate XXVIII

Plate XXIX.

Puccinia Graminis, Pers.

Shows various forms of teleutospores on *Cinna arundinacea*.



20x44 $\mu$ .

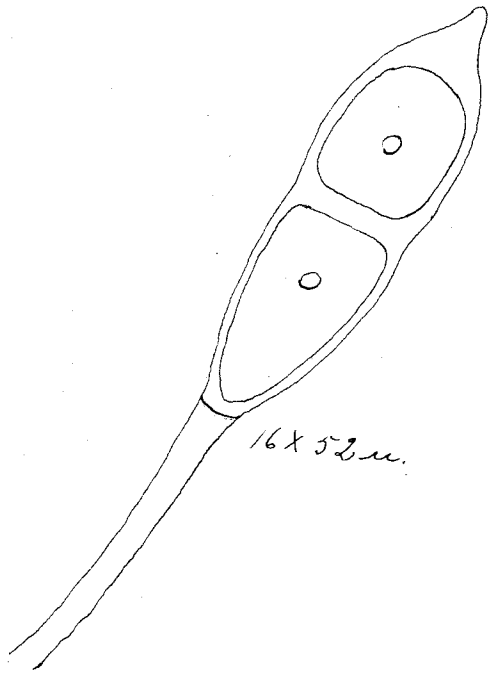

16x52 $\mu$ .

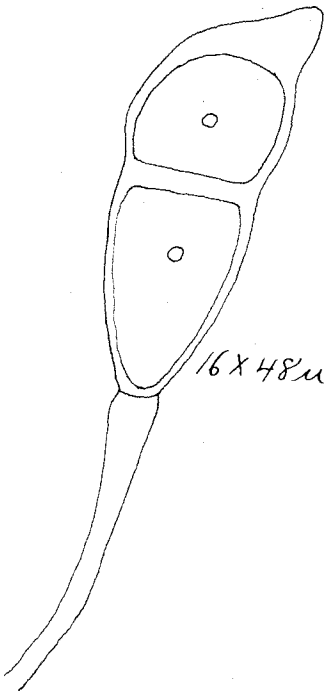

16x48 $\mu$ .

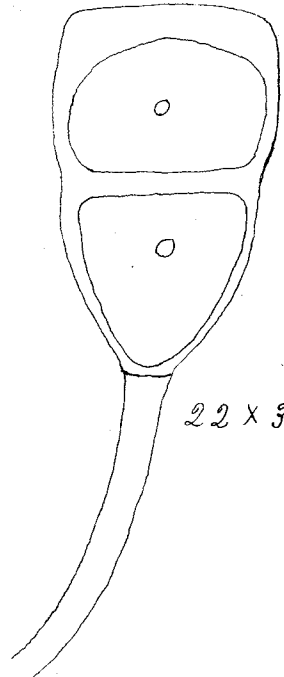

22x36 $\mu$ .

Plate XXX.

Puccinia Phragmites, (Schum.) Kornicke .

Showing various forms of teleutospores on  
Spartina cynosuroides.

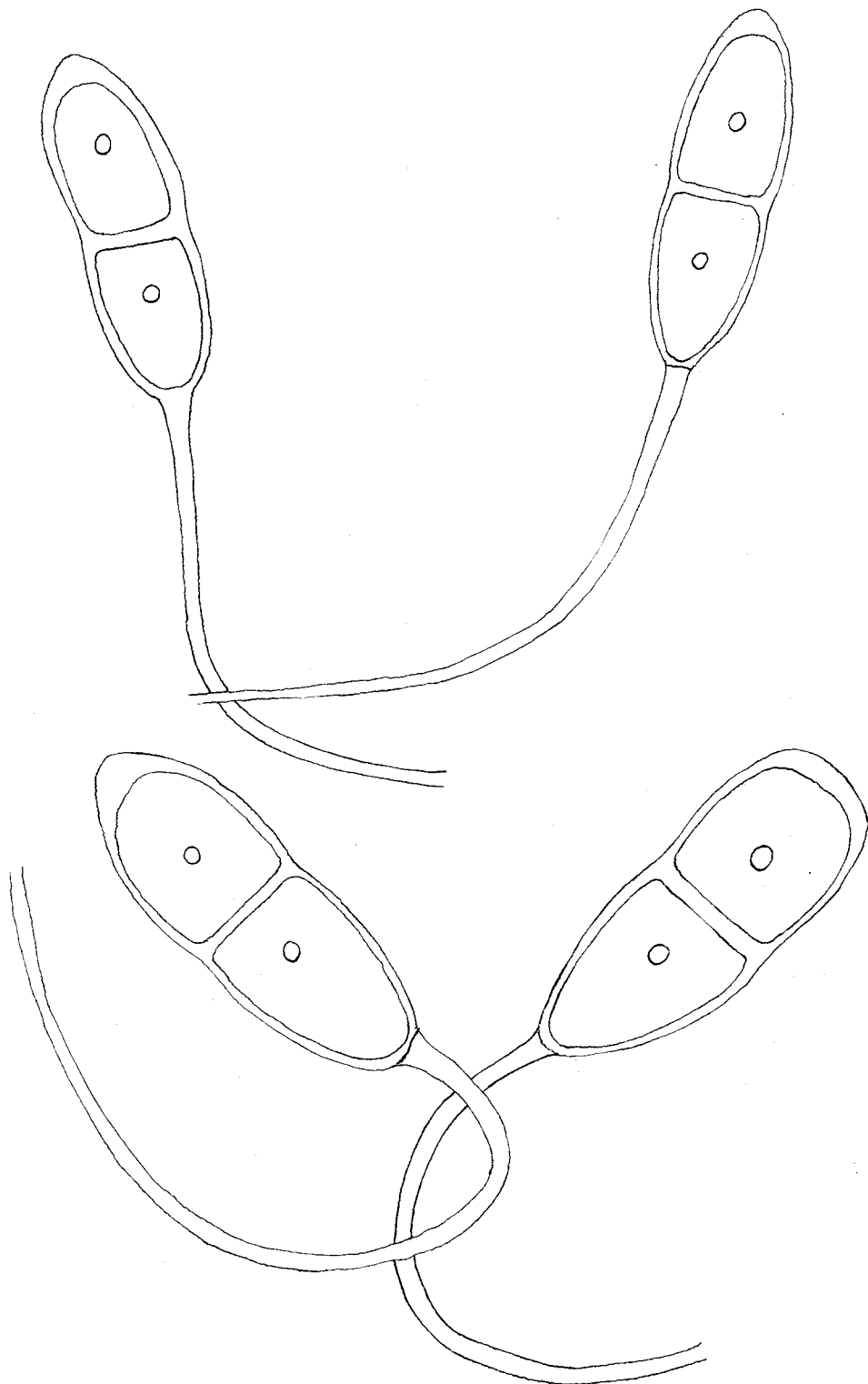

Plate XXX

Plate XXXI.

Puccinia vexans, FARLOW.

Showing various forms of teleutospores on  
*Bouteloua racemosa*.

- 1 & 2, two-celled teleutospores showing but one nuclear spot.
- 3, two-celled teleutospore showing two nuclear speacs.
4. one-celled teleutospore with no nuclear spots visible.

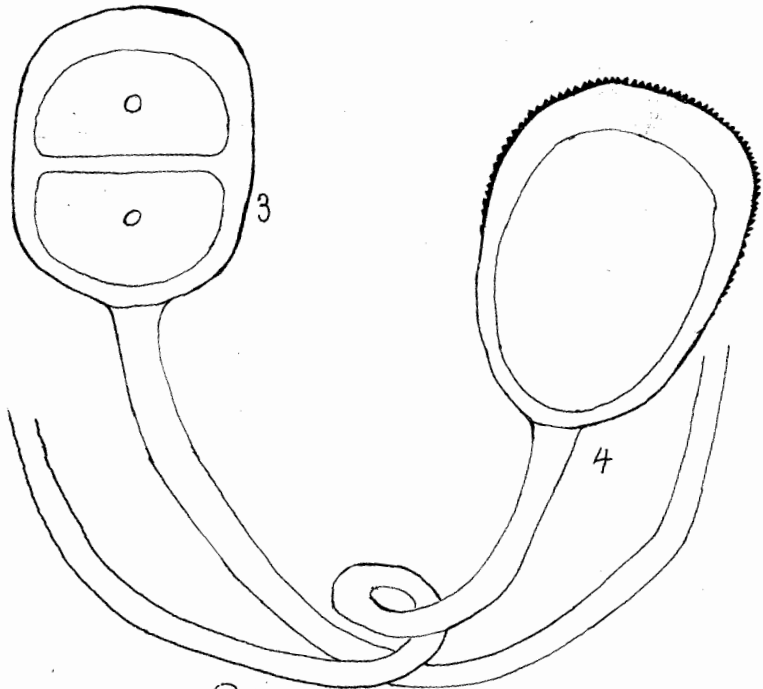
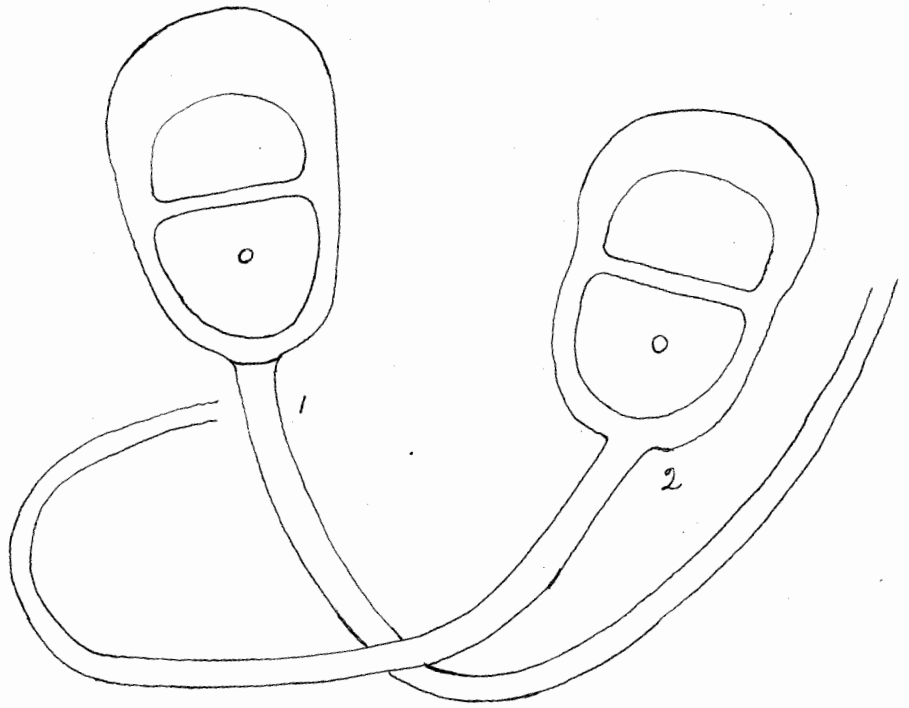

Plate XXXII.

PHYLLACHORA GRAMINIS, (PERS.) FUECKL.

Showing method of attack, development and general characteristics on *Bouteloua oligostachya*.

- 1, longitudinal section taken parallel to the surface of the leaf and showing the stroma perithecia.
- 2, cross section of leaf showing young (a) and fully developed perithecia (b).
3. fully developed asci and paraphyses.
- 4, young asci and paraphyses.



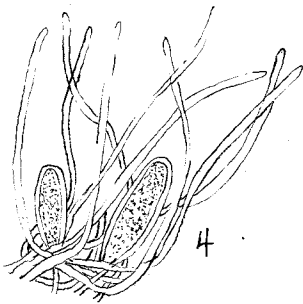
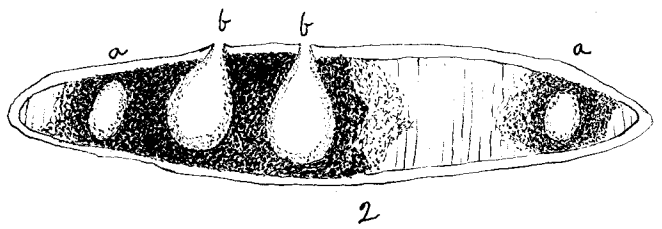
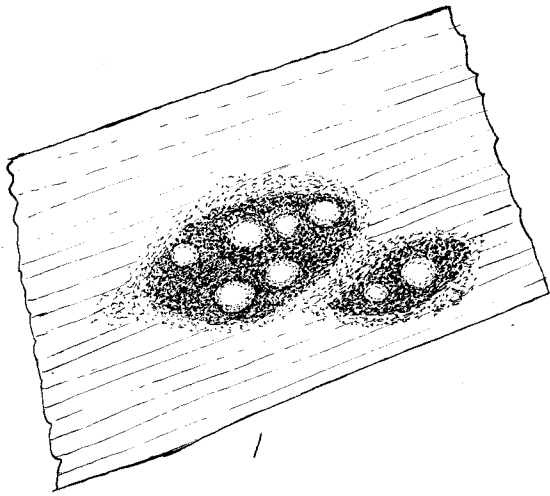

Plate XXXIII.

PUCGINIA CORONATA,   CORDA.

Showing various forms of teleutospores on  
Beckmania cruceiformis var. uniflora.

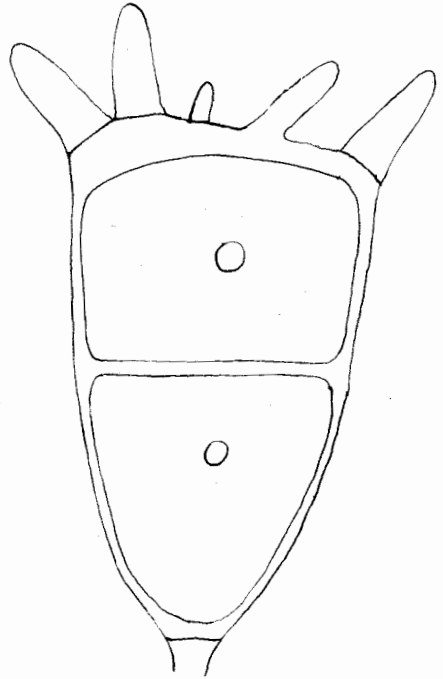
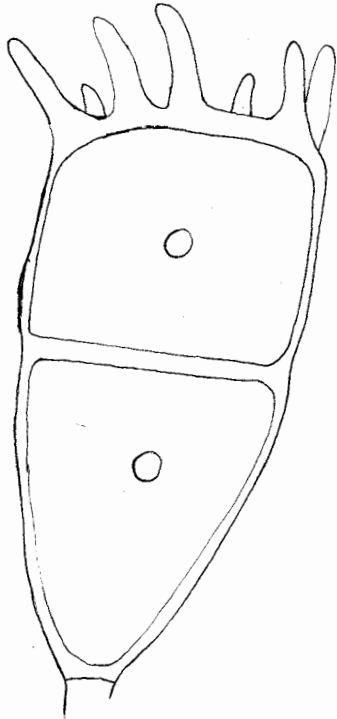
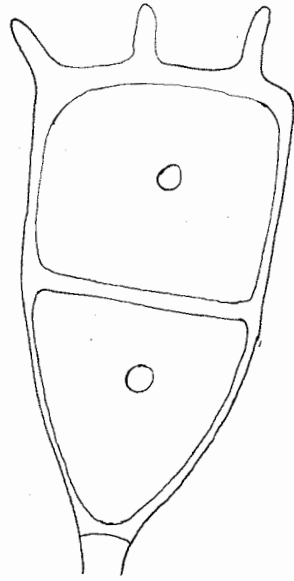
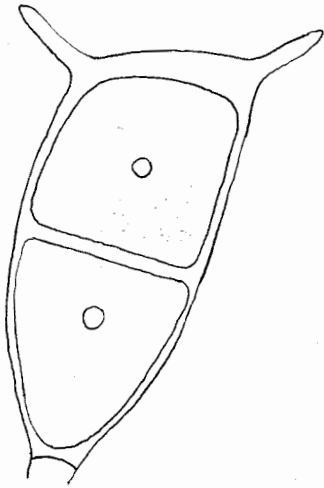

Plate XXXIV.

CERCOSPORA SEMINALIS, E. & E.

Showing method of attack and general characteristics of the fungus on *Bulbilis dactyloides*.

- 1, seed affected with the fungus.
- 2, long, branching hypha.
- 3-6, conidia highly magnified.

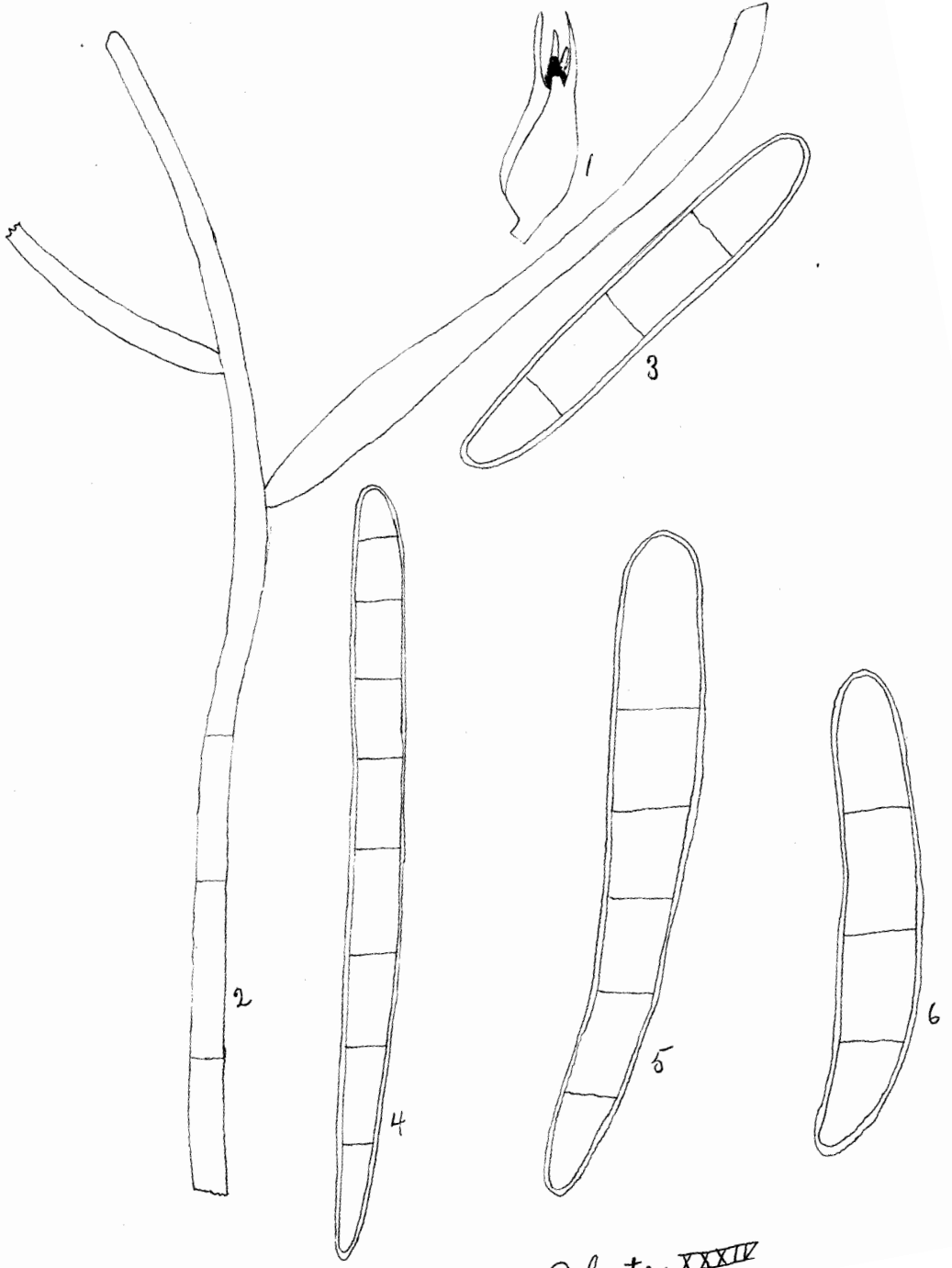

Plate XXXIV

Plate XXXV.

PUCCINIA RUBIGO-VERA, (?) (D.C.) WINT.

Showing the great variation in forms of teleuto-  
spores on *Eatonia pennsylvanica*.

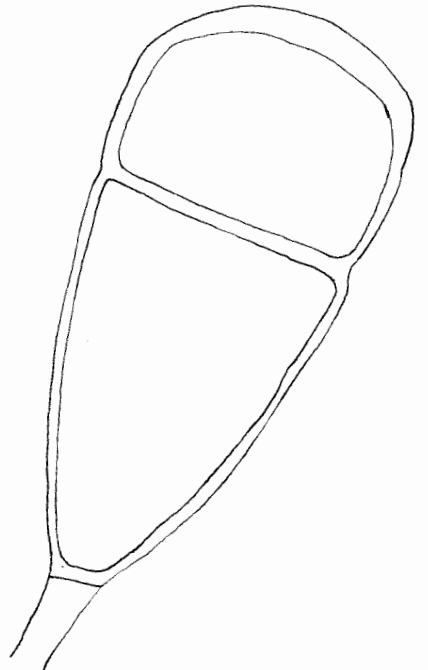
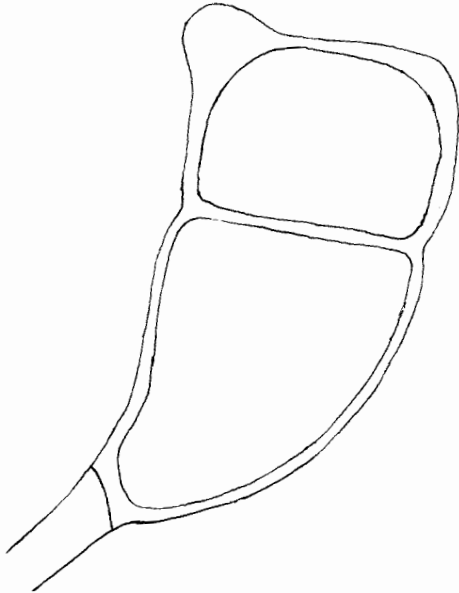
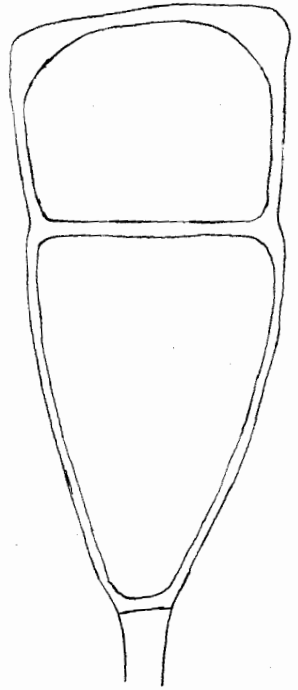
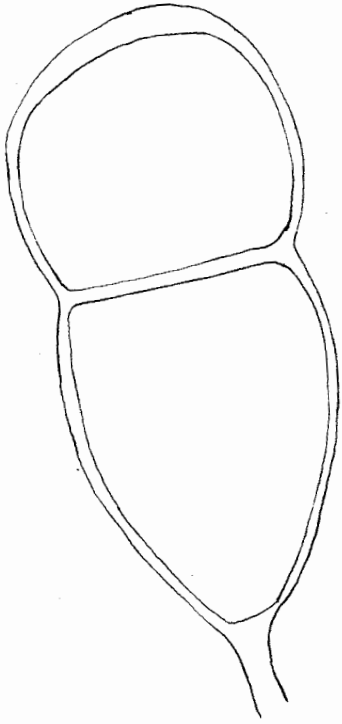

Plate XXXVI.

EPICHLÖE TYPHINIA, PERS.

Showing general characteristics and methods of attack on *Koeleria cristata*.

- 1, single affected plant.
- 2, cross section of stroma showing peritheca around the outside.
- 3, longitudinal section of the same.
- 4, portion of an ascus showing the long filiform sporidia.



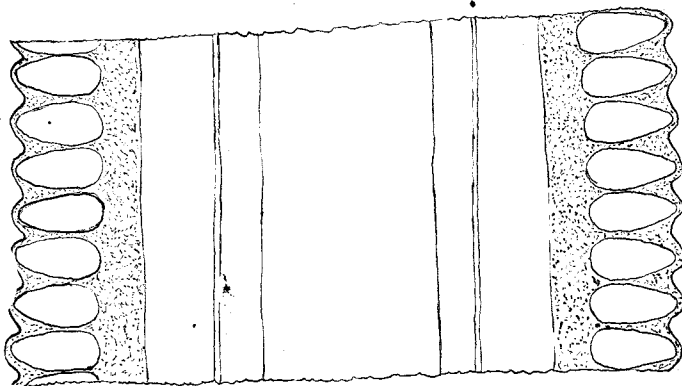
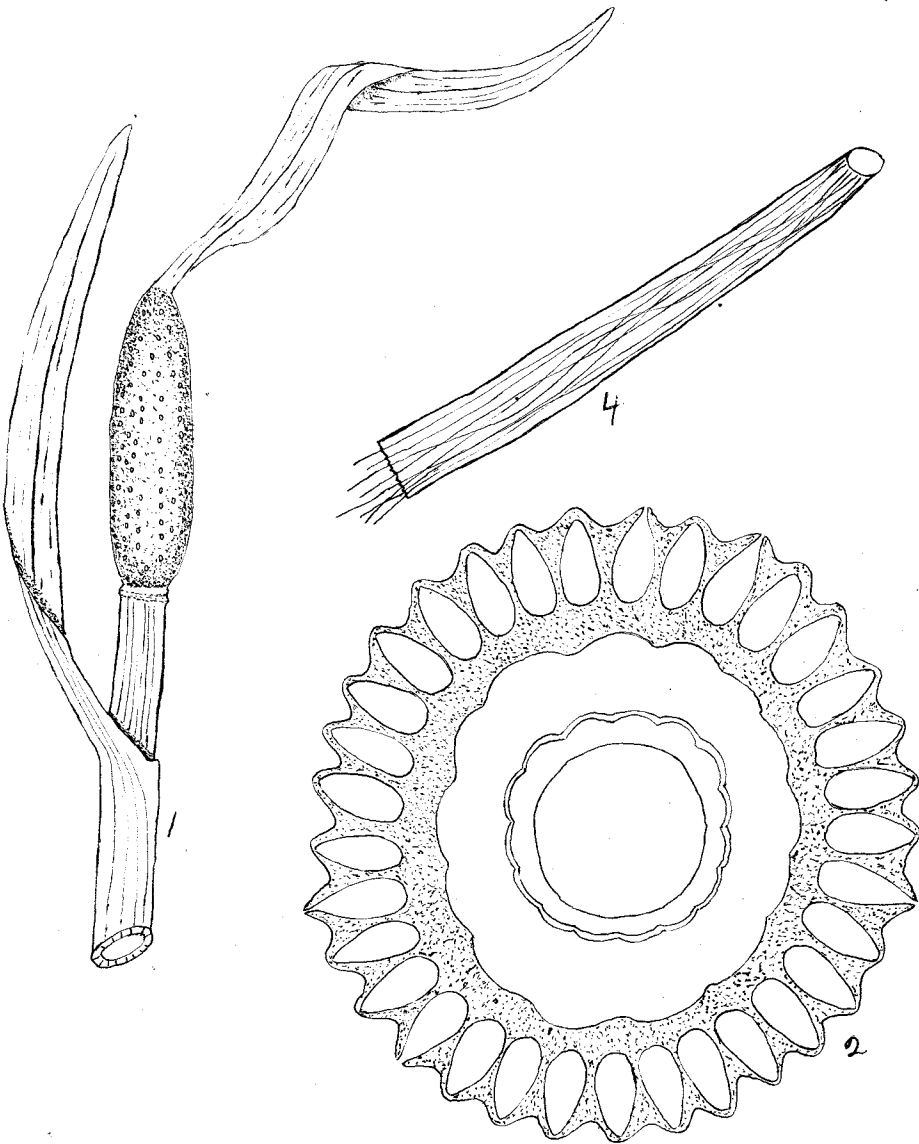

Plate XXXVII.

Puccinia n. sp.

Showing various spore characteristics on  
*Distichlis spicata.*

1 - 3 three forms of teleutospores.

4, uredospores.

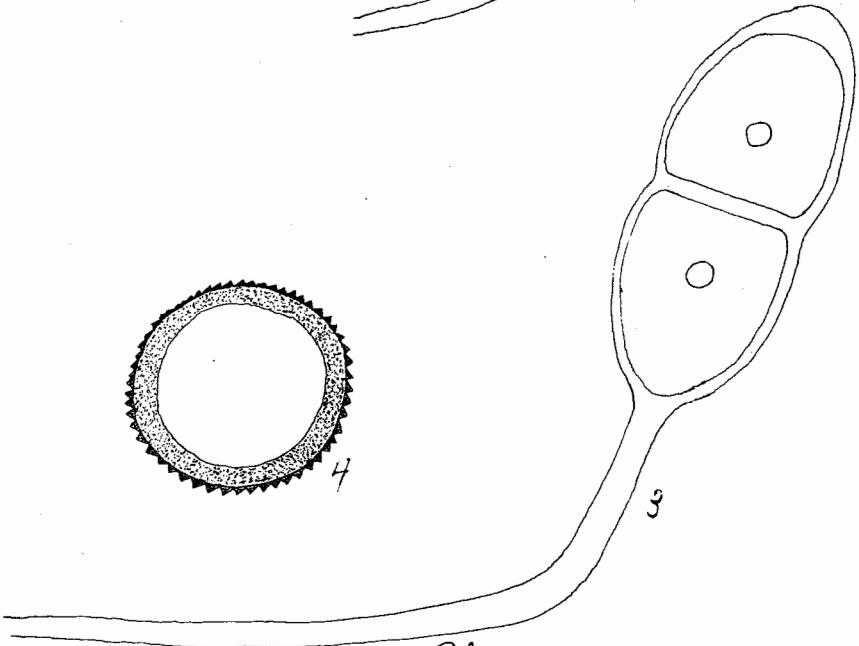
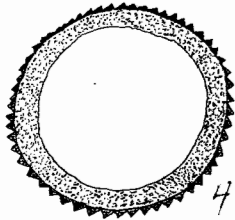
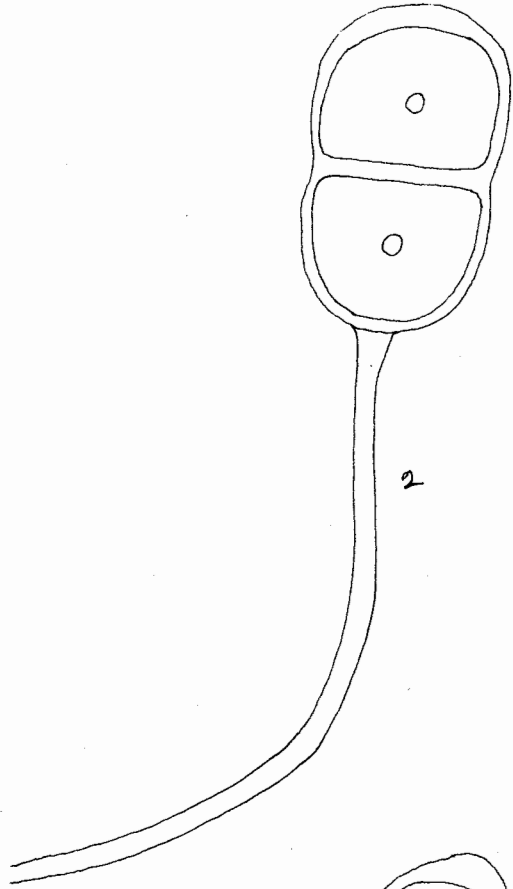
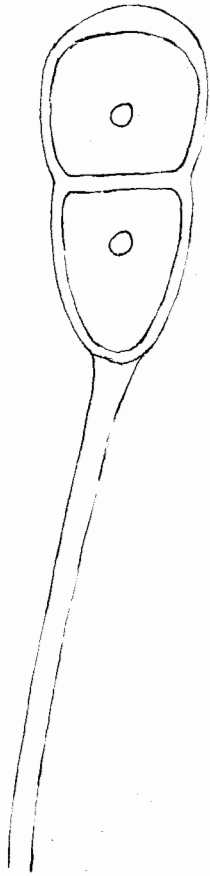

Plate XXXVIII.

Puccinia rubigo-vera, (D.C.) Wint.

Showing method of development and characteristics  
of spores on *Poa alsodes*.

1-3, young teleutospores.

4 - 6, mature teleutospores.

7, mature uredospores.

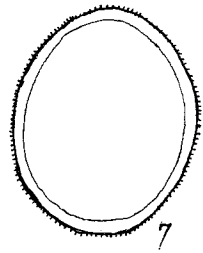
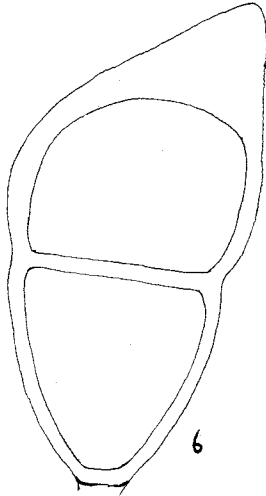
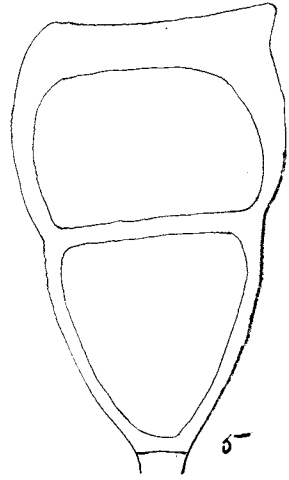
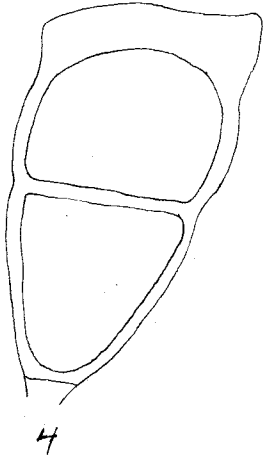
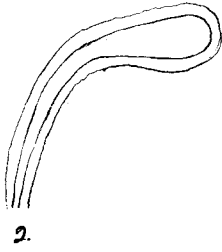

Plate XXXIX.

ERYSIPHE GRAMINIS, D.C.

Showing development, general characteristics,  
and method of attack on *Poa caesia*.

- 1, portion of a leaf with perithecia and hyphae.
- 2, perithecia with appendages.
- 3, perithecia ruptured.
- 4 - 7, asci showing various forms of appendages.

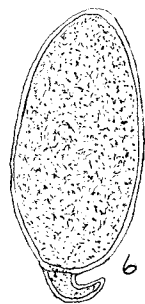
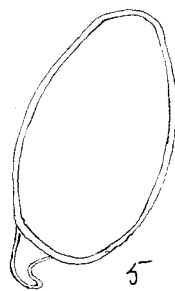
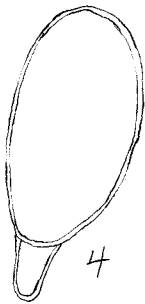
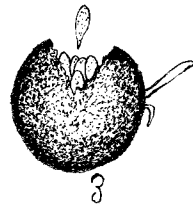
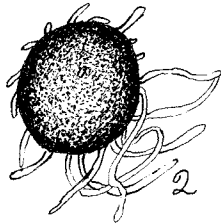
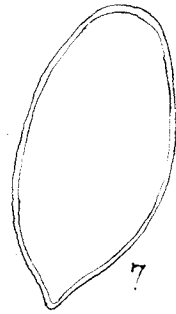
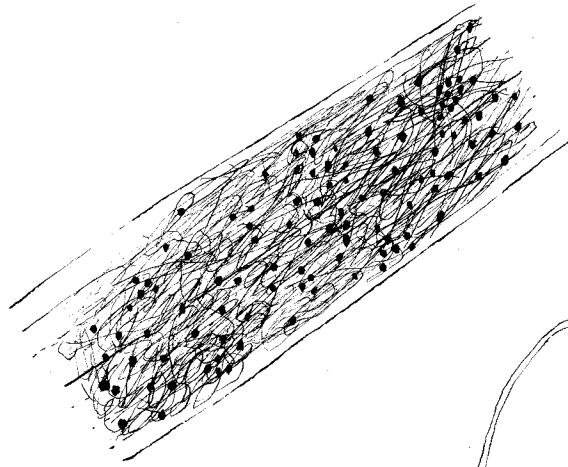

Plate XL.

ERYSIPHE GRAMINIS, D. C.

Showing general characteristics of the conidial stage on *Bromus schraderi*.

- 1, long branched hypha with young conidia attached.
- 2, conidia highly magnified.



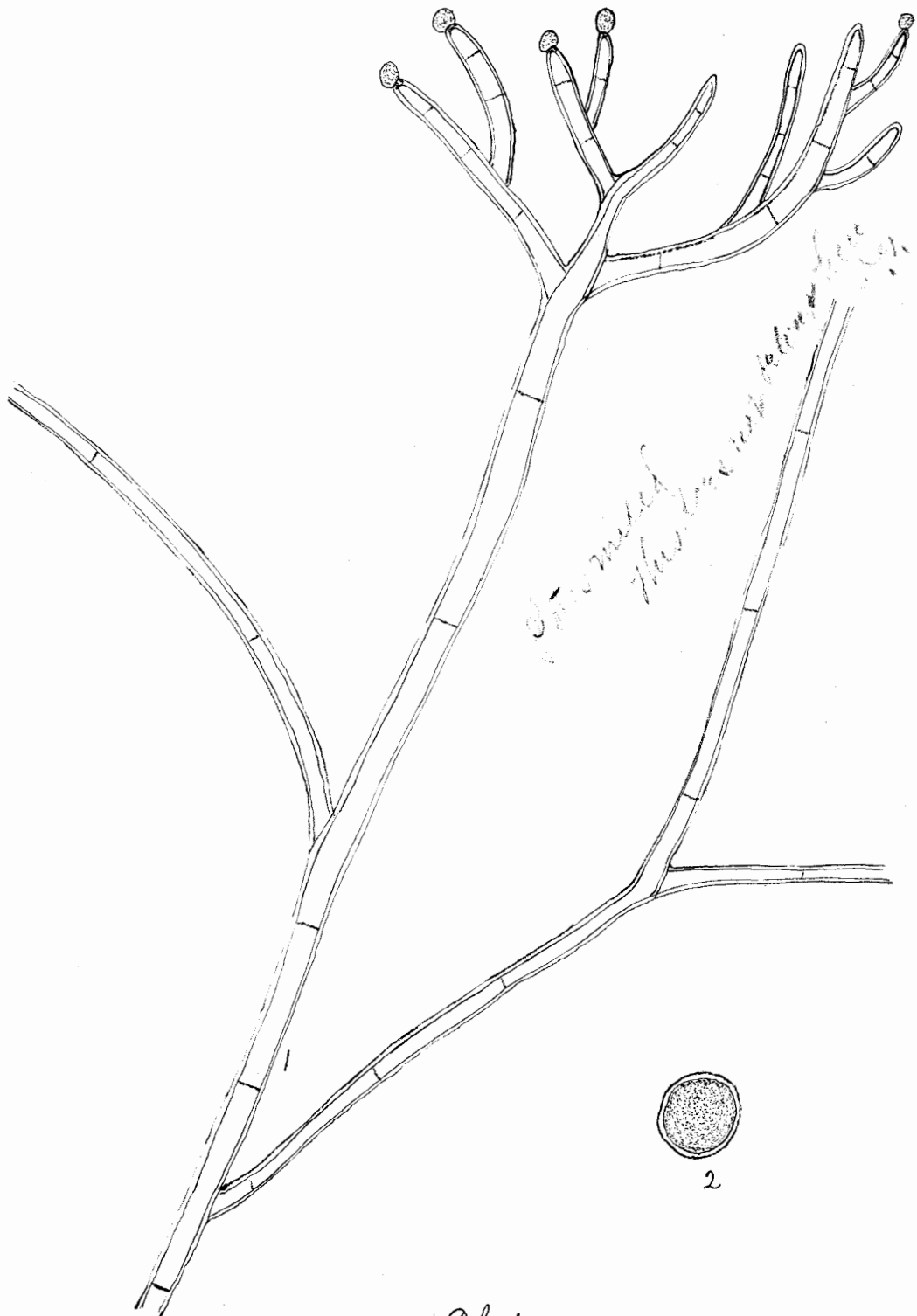

Plate XL

Plate XLI.

CLADOSPORIUM GRAMINIUM, CORDA.

Showing spore and hyphae characteristics on  
*Agropyrum glaucum*.

1, hyphae highly magnified.

2 - 10, various forms of conidia.

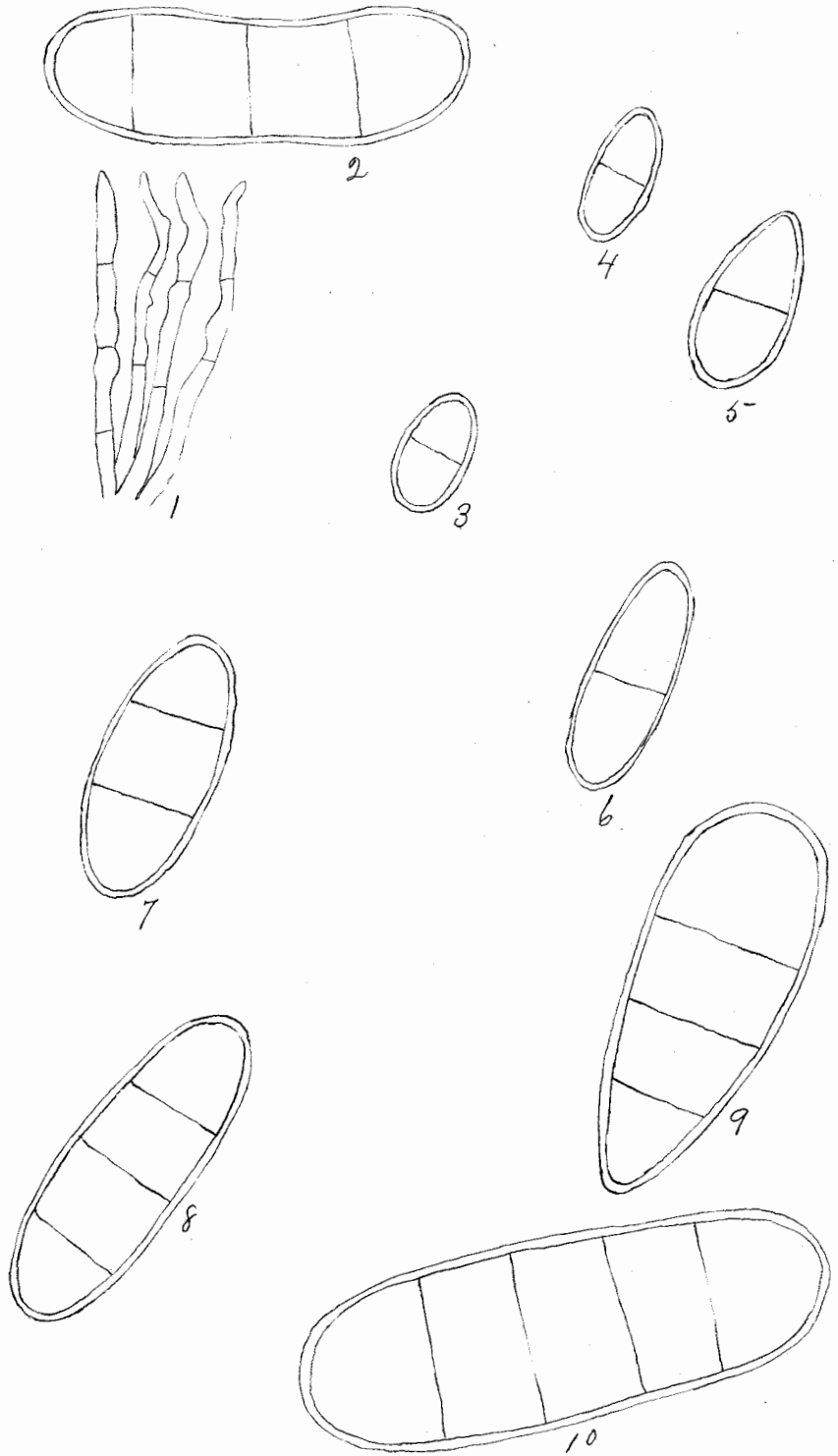

Plate XLI

Plate XLII.

Puccinia rubigo-vera, (D.C.) Wint.

Showing general characteristics of teleutospores  
on *Elymus canadensis*.

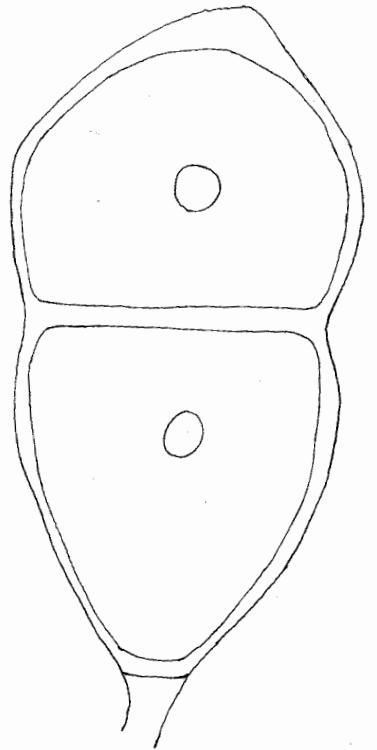
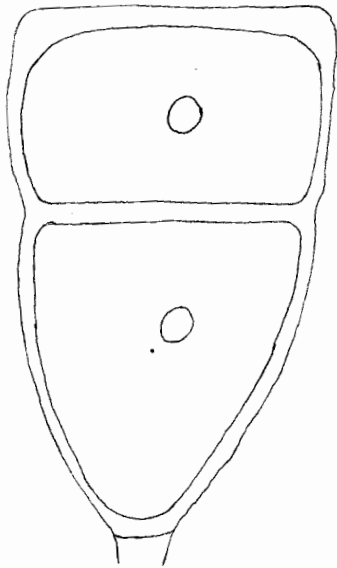
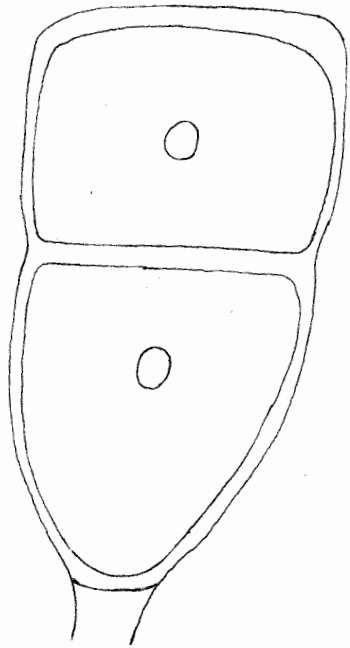
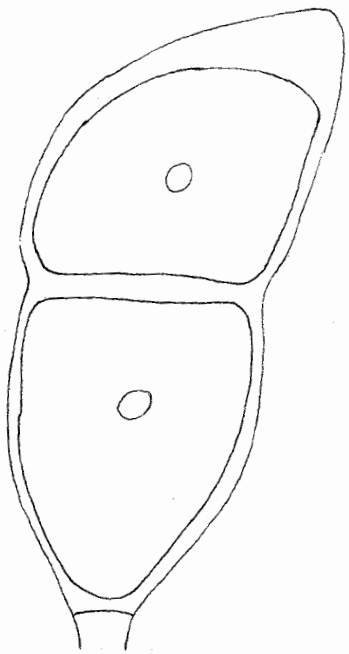

Plate XLIII.

Puccinia sp.

Showing the great variations in teleutospore characteristics on *Elymus striatus*.

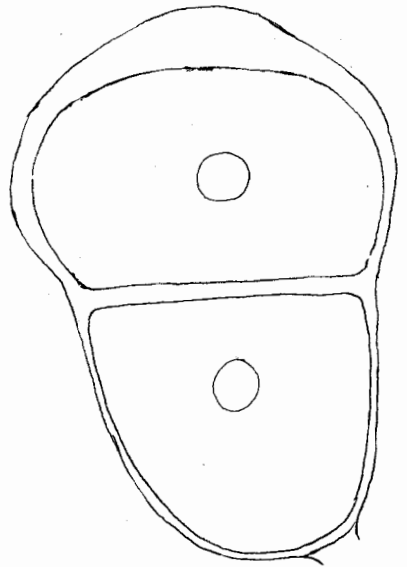
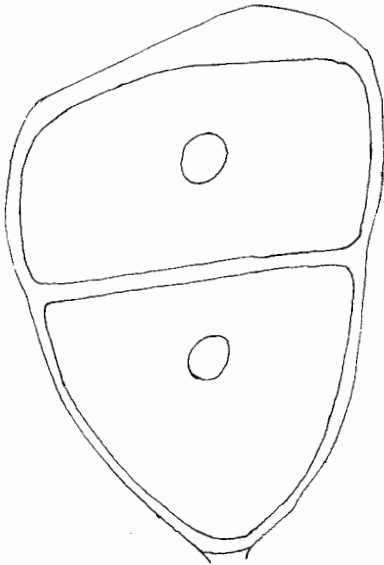
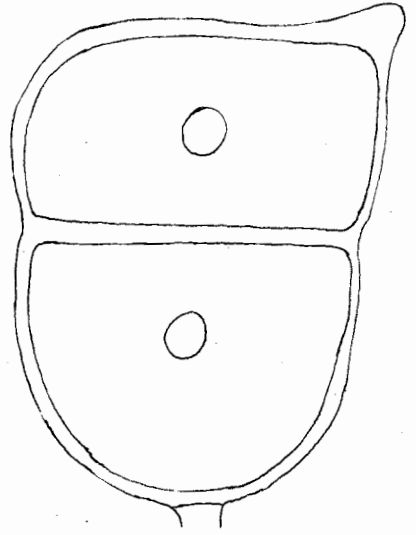
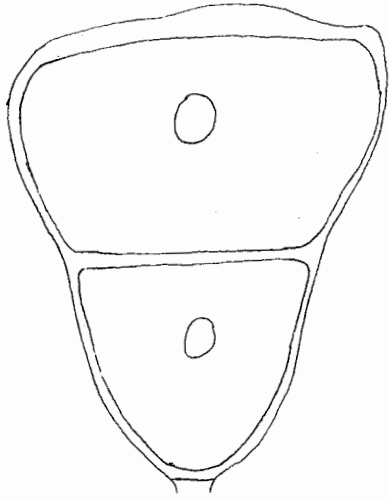

Plate XLIV.

CLADOSPORIUM GRAMINUM, CORDA.

Showing the peculiar method of attack and general characteristics on *Elymus striatus*.

- 1, seed with fungus represented.
- 2, hyphae highly magnified.
- 3 - 5, forms of conidia.
- 6, Macrosporium spore.



