

South Dakota State University

Open PRAIRIE: Open Public Research Access Institutional Repository and Information Exchange

Electronic Theses and Dissertations

1983

Optimum Irrigation Loading Rates of Highly Saline Wastewater on a Montmorillonitic Soil

John H. Bischoff

Follow this and additional works at: <https://openprairie.sdstate.edu/etd>

Recommended Citation

Bischoff, John H., "Optimum Irrigation Loading Rates of Highly Saline Wastewater on a Montmorillonitic Soil" (1983). *Electronic Theses and Dissertations*. 4324.

<https://openprairie.sdstate.edu/etd/4324>

This Thesis - Open Access is brought to you for free and open access by Open PRAIRIE: Open Public Research Access Institutional Repository and Information Exchange. It has been accepted for inclusion in Electronic Theses and Dissertations by an authorized administrator of Open PRAIRIE: Open Public Research Access Institutional Repository and Information Exchange. For more information, please contact michael.biondo@sdstate.edu.

OPTIMUM IRRIGATION LOADING RATES OF HIGHLY SALINE WASTEWATER
ON A MONTMORILLONITIC SOIL

by

John H. Bischoff

A thesis submitted
in partial fulfillment of the requirements for the
degree Master of Science, Major in Agricultural Engineering
South Dakota State University

1983

ABSTRACT

Annual applications of 125, 90, and 50 cm of secondary-treated municipal effluent were applied to a 0.76 cm/hr glaciated soil growing alfalfa for 3 years. All treatments had weekly applications with the depth of application varying from 1.5-3.2 cm for the low rate plot to 3.8-8 cm for the high plot. The amounts applied paralleled the evapotranspiration curve of the crop with weekly applications lowest in the spring and fall and highest during the summer. Water quality varied from 1500-3000 μ Siemens/cm for the electrolyte concentration, from 5-11 for the sodium adsorption ratio, and from 0.1-12.4 ppm for nitrate nitrogen.

A water table developed within 1.2 meters of the surface for the 90 cm plot (treatment 35G) and within 1.1 meters of the surface on the 125 cm plot (treatment 50) at the end of the second irrigation season. Treatment 50 had lost 1-2% of the plant population at the end of the second year and 15-20% by the end of the third year of irrigating. Leaching fractions of 0.08-0.10 for total moisture should not be exceeded to prevent water table problems from developing near the surface.

Annual soil applications of gypsum were added to the 90 cm plot (treatment 35G) to determine the efficiency in removing exchangeable sodium from the soil colloid exchange sites. After two annual applications of powdered gypsum, no significant difference between the gypsum plot (treatment 35G) and the non-gypsum plot (treatment 35) was detected in the top 1.2 meters. However, the sodium level for 35G in observation wells at the center of the plot were 2-5 times higher than the

non-gypsum plot (35) with the same annual rate of effluent. Sulphate levels were 4-8 times higher on 35G versus 35 and magnesium was 4 times higher. Calcium was replacing magnesium and sodium on the exchange complex at depths below 1.2 meters.

Nitrate levels in the soil varied according to the nitrate levels in the effluent. In situ soil water extracts were monitored with depth and time across treatments. There was no difference in the nitrate levels in the soil according to treatment. Nitrate nitrogen levels were the highest in the ground waters beneath the plot with the thickest sand layer in the subsoil.

Soil dispersion caused by sodic irrigation water for the top 3 cm of soil was evident at the end of the three-year project on the 50 cm annual application plot (treatment 20). Concentrating effects of ET and low leaching caused high sodium adsorption ratios of the soil solution (SAR_{SS}) during the irrigation season on treatment 20. Treatments 50, 35, and 35G did not show signs of soil dispersion on the top 3 cm.

OPTIMUM IRRIGATION LOADING RATES OF HIGHLY SALINE WASTEWATER
ON A MONTMORILLONITIC SOIL

This thesis is approved as a creditable and independent investigation by a candidate for the degree, Master of Science, and is acceptable for meeting the thesis requirements for this degree. Acceptance of this thesis does not imply that the conclusions reached by the candidate are necessarily the conclusions of the major department.

Dr. L. O. Fine
Thesis Advisor

/ Date

~~Dr.~~ M. A. Hellickson
Head, Major Department

Date

Dr. D. W. DeBoer
Major advisor

✓ Date

ACKNOWLEDGEMENTS

I would like to dedicate this to my family, Marilyn, Travis, Jill, and Joni. This is just a token of my appreciation for the self-sacrifices and added responsibilities you all have made during the course of this graduate work. Especially to you, Marilyn, I take this opportunity to thank you for all the late nights you spent alone, for all the support you provided for the children and me, and for the added responsibilities you took on in my absence. Yes, now that vanity in the bathroom will be built!

I, also, would like to thank Dr. L. O. Fine, Dr. C. G. Carlson, Dr. J. L. Wiersma, Dr. D. W. DeBoer, Alan Bender and countless other university staff for their guidance, support, and time which they committed to me for my educational benefit. Really, you have been wonderful to work with and I very much appreciate your dedication to help others develop their personal goals.

To all the students who helped move the irrigation pipe, dry, and weigh alfalfa, shovel gypsum (some of the professors got in on that, too!), and who waded up to their waist in "waste", I truly appreciate your commitment to hang on to your job! Without your assistance, Owen, Larry, Todd, Paul, Allen, this would have been much easier! Thanks, Sher, Kent, and Lisa for your adept skills on the HP computer. I can go on and on with the list of friends of whom I appreciate for their support and belief. Thanks, Cheryl, for being there when I expected this thesis to be typed.

I wish to thank, also, the Office of Water Research and Technology, now the Office of Water Policy, under the U.S. Department of the Interior, for making grant money available for this research.

JHB

TABLE OF CONTENTS

| | <u>Page</u> |
|-------------------------------------------------------------------------------------------------------|-------------|
| ACKNOWLEDGEMENTS | iii |
| LIST OF TABLES | vi |
| LIST OF FIGURES | vii |
| INTRODUCTION | 1 |
| LITERATURE REVIEW AND OBJECTIVES | 4 |
| MATERIALS AND METHODS | 7 |
| Experimental Procedure and Site Characteristics | 7 |
| Wastewater Characteristics | 18 |
| Agronomic Information | 19 |
| Soil Amendment Rates | 24 |
| RESULTS AND DISCUSSION | 37 |
| Forage Yields | 37 |
| Effects of Gypsum Amendments | 40 |
| Saturated Hydraulic Conductivity | 53 |
| Drainage Water Quality | 61 |
| Drainage Water Quantity | 75 |
| SUMMARY AND CONCLUSIONS | 83 |
| REFERENCES | 86 |
| APPENDIXES | 88 |
| A. Laboratory-determined parameters of field soil water extracts 1980 | 89 |
| B. Laboratory-determined parameters of field soil water extracts 1981 | 101 |
| C. Laboratory-determined parameters of field soil water extracts 1982 | 118 |
| D. Soil chemical characteristics 1980-1982. Data by treatments, depth, and sampling date | 130 |
| E. James River water quality data 1980-1982 | 149 |
| F. Secondary-treated municipal effluent water quality data at Huron 1980-1982 | 151 |
| G. Plot observation well water quality data 1980-1982 | 154 |
| H. Dry matter alfalfa yields by treatment, replication, year, and cutting 1980-1982 | 157 |
| I. Rainfall and irrigation frequency and amounts, Huron, S.D. 1980-1982 | 161 |

LIST OF TABLES

| <u>Table</u> | <u>Page</u> |
|--------------------------------------------------------------------------------------------------------------------------------------|-------------|
| 1 Clay mineralogy of a 0-30 cm soil sample (Houdek loam) . . | 10 |
| 2 Soil mechanical analysis of a 0-30 cm (Houdek loam) . . . | 10 |
| 3 Terminal average bulk densities of treatments | 11 |
| 4 Analysis of variance of bulk densities of a 0-3 cm depth using Dunnett's test | 11 |
| 5 Treatments, annual effluent rates, and soil amendments for the project | 12 |
| 6 Huron effluent organic and inorganic chemical levels as compared to EPA maximum contaminant levels (1980) . . . | 23 |
| 7 Agronomic crop information 1980-1982 | 26 |
| 8 Treatment 35G calcium requirements (1980) needed to maintain an SAR _{iw} of 3 or 5 | 28 |
| 9 Treatment 35G calcium requirements (1981) needed to maintain an SAR _{iw} of 3 of 5 | 29 |
| 10 Treatment 35G calcium requirements (1982) needed to maintain an SAR _{iw} of 3 or 5 | 30 |
| 11 Treatment 20 calcium requirements needed to maintain an SAR _{iw} at 3 or 5 | 32 |
| 12 Moisture and yield data of alfalfa plots 1980-1982 | 38 |
| 13 Single-degree-freedom partitions of treatment sum of squares for alfalfa yields (kg/ha) | 39 |
| 14 Chemical soil analysis 1980-1982 (average of 2-3 sites) | 48 |
| 15 Solubilities of CaCO ₃ at various pH's | 51 |
| 16 Replications of saturated hydraulic conductivity measurements for the top 3 cm of soil for the various treatments | 55 |
| 17 Analysis of variance for laboratory K(θ_s) measurements of the top 3 cm of soil | 56 |
| 18 Dunnett's test of check mean vs treatment means for K(θ_s) measurements | 56 |

LIST OF FIGURES

| <u>Figure</u> | <u>Page</u> |
|-------------------------------------------------------------------------------------------------------------------------------------------------------------|-------------|
| 1 Plot layout with contours and irrigation regime | 8 |
| 2 Observation well boring logs of the various treat- ments | 9 |
| 3 Water level recording device mounted over an obser- vation well | 15 |
| 4 A station of suction tensiometers and evacuated jugs at each plot | 16 |
| 5 Right and wrong way to build a suction tensiometer for obtaining soil water extracts | 17 |
| 6 Huron's secondary effluent water quality (EC, Na, SAR, adj. SAR) | 20 |
| 7 Huron's secondary effluent water quality (TKN, NO ₃ , Cl, alk(MO)) | 21 |
| 8 Huron's secondary effluent water quality (Ca, Mg, SO ₄ , alk(P)) | 22 |
| 9 Experimental plot irrigation system on 35G with new seeding of Agate alfalfa June 1980 | 25 |
| 10 Representation of the design of acrylic Tempe cell used to hold undisturbed soil cores for saturated hydraulic conductivity measurements | 34 |
| 11 Schematic representation of the design used in measuring saturated hydraulic conductivities | 35 |
| 12 Depiction of the alfalfa population reduction at the low end of treatment 50 August 1982 | 41 |
| 13 Treatment 35G plot before harvest 1982 showing yel- lowing of alfalfa because of excess water | 42 |
| 14 Soluble sodium levels with time and depth from plot 35G, 1981 | 43 |
| 15 Soluble sodium levels with time and depth from plot 50, 1981 | 45 |
| 16 Soluble sodium field extracts by depth from plot 50, 1980 | 46 |

| <u>Figure</u> | <u>Page</u> |
|-------------------------------------------------------------------------------------------------------------------------------|-------------|
| 17 Graphical depiction of the change of $K(\theta_g)$ with increasing pressure heads on two treatments | 58 |
| 18 Changes in observation well water quality (EC, Na, Cl, NO ₃) with time for plot 50 | 63 |
| 19 Changes in observation well water quality (EC, Na, Cl, NO ₃) with time for plot 35G | 64 |
| 20 Changes in observation well water quality (EC, Na, Cl, NO ₃) with time for plot 35 | 65 |
| 21 Changes in observation well water quality (EC, Na, Cl, NO ₃) with time for plot 20 | 66 |
| 22 Nitrate levels at various times and depths in the soil solution from plot 50, 1981 | 67 |
| 23 Effect of a heavy rainfall on the salinity in the soil profile for plot 50, 1981 | 69 |
| 24 EC values in the soil with time and depth on plot 35G, 1981 | 71 |
| 25 Changes in pH in the soil with depth and time for plot 50, 1981 | 73 |
| 26 Changes in pH in the soil with depth and time for plot 50, 1982 | 74 |
| 27 Bicarbonate ion concentration in the soil with depth and time in plot 50, 1982 | 76 |
| 28 Cumulative precipitation departures from the normal 30 year average of 40.6 cm (16 in) for Huron, S.D. 1980-1982 | 78 |
| 29 Water table levels obtained from observation wells for 1981 for the various treatments | 79 |

INTRODUCTION

Municipal wastewater disposal has been a concern and a problem for mankind since community sewage systems were first developed. Surface waters were extremely convenient for disposing of raw wastes because of their ability "to dilute" the pollutants to make them less hazardous. Eventually, however, as the pollutant volumes exceeded the dilution volumes the water quality deteriorated rapidly. Thus, came the need for treatment of wastes to prevent point-source pollution of streams and lakes.

Sanitary engineers have been familiar with land treatment of wastes for centuries. Ancient Greek and European "sewage farms" have been reported as very successful and still in existence today (1). As modern technology developed methods of wastewater treatment which met the discharge requirements of the times, and public acceptance of "sewage farming" dwindled, the soil, as a means of wastewater treatment, became a minority alternative among engineering consulting firms.

It wasn't until 1972, when more stringent regulations formulated from the Federal Water Pollution Control Act Amendments (Public law 92-500) were finalized, that land application regained popularity due to economic considerations for smaller communities. Amid the regulations a statement that said any community who chose land application as a cost-effective viable alternative for wastewater treatment and disposal was eligible for 75% of the cost of that system paid for by federal funds. In South Dakota, 175 communities utilize lagoons for wastewater treatment and stabilization (2). Of those 175 communities, approximately 50

are considered suitable for irrigation based on an empirical formula developed from one season's sampling (2). Approximately 45 of the communities had water quality in the range of 2000-3500 $\mu\text{S}/\text{cm}$ and/or SAR's in the range of 5-10 which classified them as marginally suitable for irrigation. These marginally suited lagoons amount to approximately 400 hectares serving 50,000 people. Because most of those communities are small, tertiary treatment facility costs loom like an ominous black cloud. Consequently, land application systems may provide an alternative for wastewater disposal not only for cost-effective treatment but also as a resource for increased agricultural crop production.

If irrigation is a possible alternative for wastewater disposal, one of the main considerations is to minimize capital and annual costs which include land, water spreading equipment, maintenance, and energy. Therefore, the objective is to provide a maximum amount of water on a minimum amount of land area while maintaining a productive agronomic resource. This is especially important where soils which have adequate internal drainage are scarce. This type of management is contrary to conventional irrigation practices. Little information is available in regard to high hydraulic loading rates on fine-textured glaciated soils for this particular application.

In addition to the hydraulic loading aspect, many lagoons are poor in terms of water quality for conventional irrigation because of the high sodium content contributed by water softening brine, street runoff, and human wastes. When sodic waters are applied to montmorillonitic soils, studies have demonstrated that the saturated hydraulic conductivity decreases with decreasing electrolyte concentrations

for a given SAR of the applied water (4,5,6). It is a well-established fact that soil salinity, and, to some extent, sodicity can be reduced by increased leaching fractions if the soil will accept the increased hydraulic load (3). Usually, calcium and magnesium are accordingly high when the sodium level is high for many irrigation wells in South Dakota. However, this may not be so in the case of many municipal effluents because of the additional sodium added for water softening. Consequently, the potential for using these effluents for irrigation may be feasible only if applications of soil amendments are made either in the irrigation water or on the soil to maintain soil permeabilities. Nevertheless, the added costs of these amendments and the limitation to moderately salt tolerant to salt tolerant crops may prove to be less costly than a tertiary treatment facility. High level soil-crop management and monitoring would have to be included for such a system to be feasible, however.

LITERATURE REVIEW AND OBJECTIVES

The University of Minnesota and Agricultural Research Service did extensive studies using wastewaters for irrigation at Apple Valley 1972 through 1977 (7, 8, 9, 10). Their main concerns dealt with nitrogen removals and differences in crop yields and persistence of forage crops with different cutting regimes. They worked with a constant weekly application (5, 10, and 13 cm/wk) from April through October with annual amounts of 137 and 240 cm on forage and 109 and 197 cm on corn. They also were working on a well-drained silt loam soil with gravel outwash at 60 cm with a water table at approximately 150 cm. The secondary treated effluent had an average EC of 1695 $\mu\text{S}/\text{cm}$ and an SAR of 5.7. They concluded that most nitrogen removal was by crop uptake and that forage removed considerably more than corn.

Karlen, et al. (11) used simulated municipal effluent of annual hydraulic loading rates of 25, 50, 100, and 200 cm on corn to determine optimum yields and hydraulic loading rates on a tiled, loamy, calcareous till. The application rate was .78 cm/hr, but the water quality was excellent in terms of lagoon effluent (EC \approx 1800 $\mu\text{S}/\text{cm}$, SAR=2-3). They concluded that tile drained Conover loam should not receive over 100 cm annual loading to derive beneficial nutrient uptake by plants.

Adriano et al. (12) evaluated the long term renovating capacities of land treatment systems under sprinkler irrigation and looked at the soil profile distributions of N, PO_4 , and organic C. They looked at average daily applications of 5 and 10 cm on sand and loamy sands with gravel outwash subsoil. Again, the wastewater quality used of 1350 $\mu\text{S}/\text{cm}$

total salinity and an SAR of 4.3 is considered good in a semi-arid climate.

Bole and Bell (13) worked with yield differences and chemical composition of forage crops with lagooned municipal wastewater on a loamy sand with an infiltration rate of 15 cm/hr. Application rates were 1.7 and 3.4 cm/hr with annual loading rates of 50 through 150 cm.

Ellis et al. (14) concluded that applying more than 88 to 100 cm of annual effluent to a .5 cm/hr loam would hydraulically overload the soil, causing the biosystem to lose its renovation capacity.

Our approach was to work with weekly applications which paralleled the ET curve of alfalfa over the season and to allow for some relief after a substantial rain. A moisture tolerant alfalfa was selected as the forage because of its agronomic value and its ability to use high amounts of N and water. A water quality of 2000 to 3000 $\mu\text{S}/\text{cm}$ and an SAR of 7-9 was desired to test the marginally suited lagoon waters. A soil type was selected which represented an extensive soil series throughout eastern South Dakota which was classified in the 0.75 cm/hr intake family by the Soil Conservation Service. The site selection was based not only on water quality and soil parameters but also on the fact that the city of 15,000 was looking for possible alternatives to effluent disposal in the James River. Therefore, this three-year study was undertaken to explore the possibility of using marginally suited lagoon effluents for irrigation and feasible forage crop production in a semi-arid climate on marginally suited soils. The main objectives were:

- (1) to determine the annual rate of hydraulic loading for a relatively fine textured montmorillonitic soil that will allow

sustained crop production, maintain acceptable soil structural and chemical characteristics, while providing for a cost-effective municipal waste disposal system;

- (2) to determine the quantity and quality of the drainage water passing below the root zone under different hydraulic loading rates;
- (3) to determine the effect of gypsum amendments upon soil exchangeable sodium percentages and physical characteristics, and crop production.

MATERIALS AND METHODS

Experimental Procedure and Site Characteristics

The study was conducted on a Houdek loam (subgroup=Typic Argiustoll; family=fine-loamy; mixed, mesic) located adjacent to the city of Huron's 130 ha stabilization ponds. The soil which developed from loamy, calcareous till is nearly level with slopes from 0-2% (Figure 1), has slow surface run-off, has moderate permeability for the solum for moderately slow permeability for the underlying till, and received approximately 45-52 cm (17-20 inches) of annual precipitation. The soil below 30 cm is mostly clay loam and, occasionally, silt loam; however, boring logs of the observation wells show scattering of sand lenses at various depths and sites (Figure 2). Clay mineralogy and bulk density are quite significant in determining hydraulic conductivities of soils. Tables 1 and 2 show the clay mineralogy and texture of a 0-30 cm composite sample. There were only small amounts of montmorillonite and mica and traces of kaolinite detected by X-ray diffraction. This indicates that probably some of the clay is amorphous and/or poor crystalline structure which caused low relative amounts in the diffraction analysis. Table 3 lists the average bulk densities of the different treatments. They range from a low of 1.34 to 1.61 with an average bulk density of 1.47. Table 4 shows the analysis of variance of the bulk densities compared to the check. The bulk density for treatments 50, 35, and 20G are significantly higher than the check at the .05 level. The bulk density for treatment 35 is significantly different at the .01 level.

Approximately 1/3 hectare plots were established with three basic annual effluent loading rates of 125, 90 and 50 cm, hereafter designated

LAYOUT OF ALFALFA PLOTS

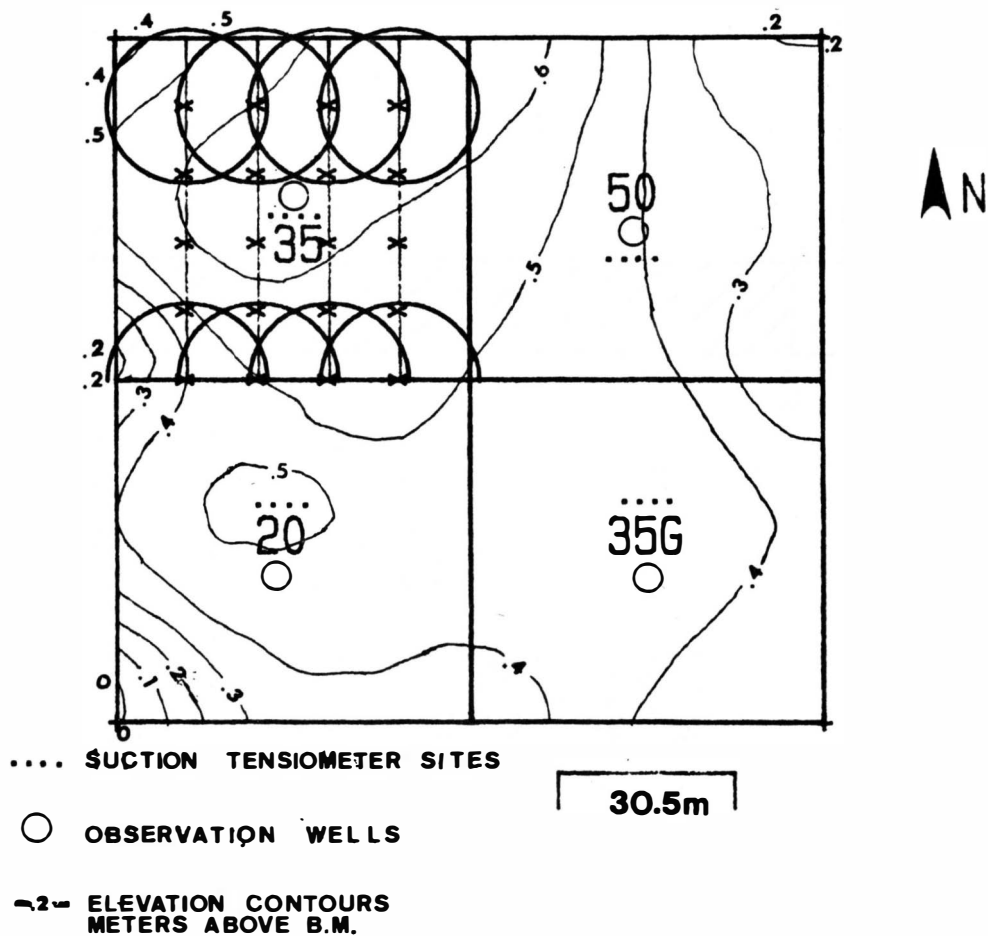

Figure 1. Plot set-up for alfalfa with a portion of the full and half-circle sprinklers represented showing overlap.

Boring Logs of Observation Wells 10/30/80

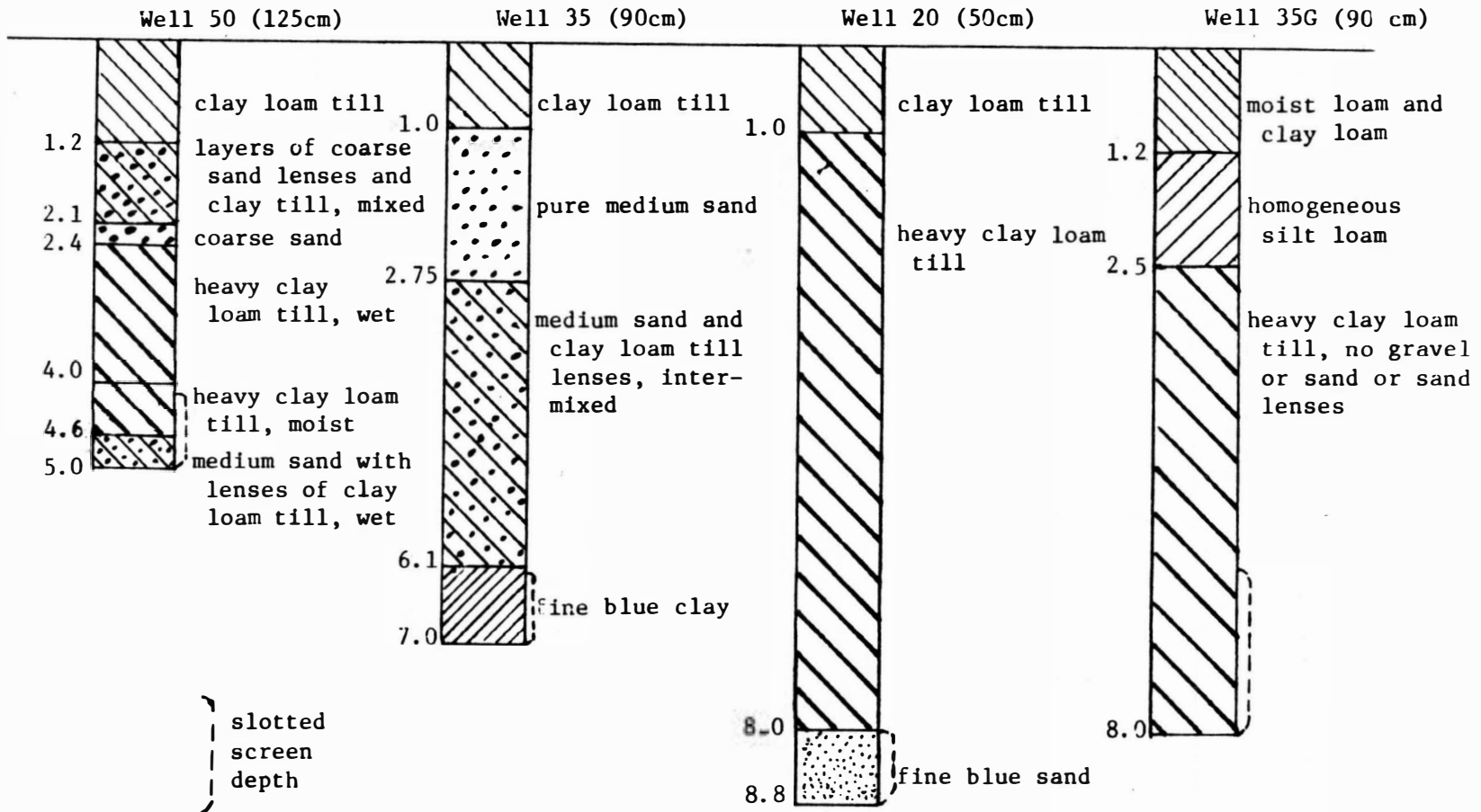

Figure 2. Observation well boring logs for the different treatments. Depths are in meters.

Table 1. Clay mineralogy of the 30 cm depth sample (courtesy of Midwest Technical Service Center, Soil Conservation Service, U.S. Dept. of Agriculture, Lincoln, Nebraska).

| <u>Soil</u> | <u>Clay mineralogy</u> |
|--------------------------------------------------|------------------------|
| Houdek | MT2 MI 2 KK 1 |
| MT--montmorillonite MI--mica KK--kaolinite | |
| Relative amount: 2--small, 1--trace | |

Table 2. Soil mechanical analysis of a sample taken from the top 30 cm.

| <u>Order</u> | <u>Subgroup</u> | <u>Series</u> | <u>Depth</u> | <u>Total</u> | | | | |
|--------------|---------------------|----------------|--------------|----------------------------------------|-------------------------------------|--------------------------------------|--------------------------------|------------------------------------|
| | | | | <u>Clay</u> <u><.002mm</u> | <u>Silt</u> <u>.002-.05mm</u> | <u>Sand</u> <u>.05-2mm</u> | | |
| Mollisol | Typic argiustoll | Houdek loam | 0-30cm | 22.1% | 32.9% | 45.0% | | |
| | | | | <u>Clay</u> | <u>Silt</u> | | | |
| | | | | <u>Fine clay</u> <u><.0002mm</u> | <u>Fine silt</u> <u>.002-.02</u> | <u>Coarse silt</u> <u>.02-.05</u> | | |
| | | | | 14.2% | 17.9% | 15.0% | | |
| | | | | <u>Sand</u> | | | | |
| | | | | <u>Very fine</u> <u>.05-.10mm</u> | <u>Fine</u> <u>.10-.25mm</u> | <u>Medium</u> <u>.25-.50mm</u> | <u>Coarse</u> <u>.5-1mm</u> | <u>Very coarse</u> <u>1-2mm</u> |
| | | | | 3.8% | 12.3% | 18.9% | 9.1% | 0.9% |

Table 3. Terminal average bulk densities of treatments.

| <u>Depth (cm)</u> | <u>50</u> | <u>35G</u> | <u>35</u> | <u>20</u> | <u>20G</u> | <u>Check</u> |
|-------------------|-----------|------------|-----------|-----------|------------|--------------|
| 0-3 | 1.39 | 1.39 | 1.53 | 1.34 | 1.53 | 1.25 |
| 15-30 | | 1.42 | | 1.46 | | |
| 30-45 | | 1.47 | | 1.45 | | |
| 45-60 | | 1.49 | | 1.45 | | |
| 60-75 | | 1.46 | | 1.46 | | |
| 75-90 | | 1.61 | | 1.40 | | |
| 90-105 | | 1.56 | | 1.41 | | |
| 105-120 | | 1.56 | | 1.47 | | |
| 120-135 | | 1.60 | | 1.51 | | |
| 135-150 | | 1.53 | | 1.56 | | |

Table 4. Analysis of variance of bulk densities between treatments for the 0-3 cm using Dunnett's test.

| | |
|--------------|---------|
| Check vs 50 | 2.71 * |
| Check vs 35G | 2.61 |
| Check vs 35 | 5.41 ** |
| Check vs 20 | 1.03 |
| Check vs 20G | 3.17 * |

Critical value of $d_{.05} (5,33) > 2.65$; $d_{.01} (5,33) > 3.31$.

*Significant at the .05 level.

**Significant at the .01 level.

as treatment 50, 35, and 20, respectively (Table 5). Another plot (35G) was established identical to the 90 cm plot with the only difference being the annual application of gypsum.

Table 5. Treatments, annual effluent rates and soil amendments for the project.

| <u>Treatment #</u> | <u>Annual effluent cm (in.)</u> | <u>Annual amendment rates CaSO₄·2H₂O</u> | | |
|--------------------|-------------------------------------|--------------------------------------------------------------------|----------------|---------------|
| | | <u>kg/ha (tons/acre)</u> | | |
| | | <u>1980</u> | <u>1981</u> | <u>1982</u> |
| 50 | 127 (50) | | | |
| 35 | 90 (35) | | | |
| 35G | 90 (35) | 2422 (1.17) | 3660 (1.63) | |
| 20 | 50 (20) | | | |
| 20G ('82 only) | 50 (20) | | | 9000 (4.0) |
| Check | 0 (0) | | | |

In 1982, treatment 20 was split in half with the east half receiving 9000 kg/ha of gypsum in the spring. This was a test to see if a heavy, unincorporated one-time application of gypsum would cause any significant change in the ESP levels at the end of the irrigation season.

The four plots were then irrigated with unchlorinated secondary treated wastewater from the last stage of stabilization ponds. The water was applied to all plots at 1.0 cm/hr with a solid set impulse sprinkler system (Figure 1). The water was pumped from the last stage of the 130 ha stabilization ponds to the plots approximately .8 km (.5 mile) away. A 22 kw (30 hp) electric motor and centrifugal pump was used to deliver approximately 454 liters/min (120 gpm) per plot at 380 KPascals (55 psi). The nozzle size was 4.36 mm (11/64 inch) diameter which delivered approximately 23.8 liters/min (6.3 gpm) for the full circles and 3.175 mm (1/8 inch) diameter for the part circles

delivering 12.9 liters/min (3.4 gpm). The frequency of application was the same for all plots, usually weekly; however the depth of application varied among plots according to the ratio among the different annual loading rates. All plots then received a specific amount at each irrigation (Appendix I lists the rainfall and irrigation amounts for the project treatments by year). A water meter was used to determine the amount for each plot assuming average irrigation efficiencies of .8. The water was applied parallel to the ET curve of the alfalfa crop, with consideration given to recent precipitation patterns. Consequently, weekly applications varied from 1.5 to 3.2 cm on the 20 plot and 3.8 to 8 cm on the 50 plot.

Because of the lack of penetration of water into the root zone on the 20 plot from the shallow frequent applications of water during 1981, water was applied every third week with the application depth three times as great for 1982. This assured better distribution of water and salts throughout the root zone.

Neutron probe access tubes were installed to 1.7 m at the center of each plot to monitor changes in soil moisture. A neutron radiating moisture meter was used to determine volumetric moisture contents at different levels. Readings were taken before each irrigation to determine the soil's capacity to accept more water.

Ten cm diameter observation wells were installed at the center of each plot (Figure 1) for the purpose of monitoring groundwater levels and quality. Medium sand was packed around the casing with bentonite grouted near the surface to guard against short-circuiting. Water level recording meters were housed and situated over the wells with floats

inside the well casing (Figure 3). Water quality samples were taken approximately once a month and analyzed for EC, Na, NO_3 , HCO_3 , pH, Cl, and NH_3 .

Soil samples were taken initially before irrigation started to a depth of 120 cm and every year thereafter at the end of the irrigation season. Four to six sub-samples were composited from each site/depth at 30 cm intervals with 3 sites per treatment. The soils were air dried, ground and sieved and checked for exchangeable Na, Ca, and Mg, EC of the saturation extract, cation exchange capacity (CEC), SAR of soil solution, and pH, using the methods described in U.S. Agricultural Handbook 60 (15). At the end of 1981, the exchangeable sodium percentage (ESP) on treatment 20 was reported higher than expected. Therefore, the top 30 cm was sampled at 6 additional sites per treatment in the spring of 1982 to check this and to see if changes occur over the winter. In total, five sampling periods were made: spring 1980, fall 1980, fall 1981, spring 1982, and fall 1982.

Suction tensiometers were also installed near the center of each plot to a depth of 150 cm (~5 ft) at 30 cm (1 ft) intervals for the purpose of evaluating the leaching water with depth under different loading rates (Figure 4). Each tensiometer was equipped with a small nylon tube which led to a 4 liter glass jug which was evacuated weekly prior to an irrigation. Any moisture in the soil held at less than .67-.80 bar could then move into the ceramic cup at the bottom of the tensiometer. At this point, one important aspect of suction tensiometer construction should be mentioned. Figure 5 shows a simplified version of the correct way and the wrong way to build a

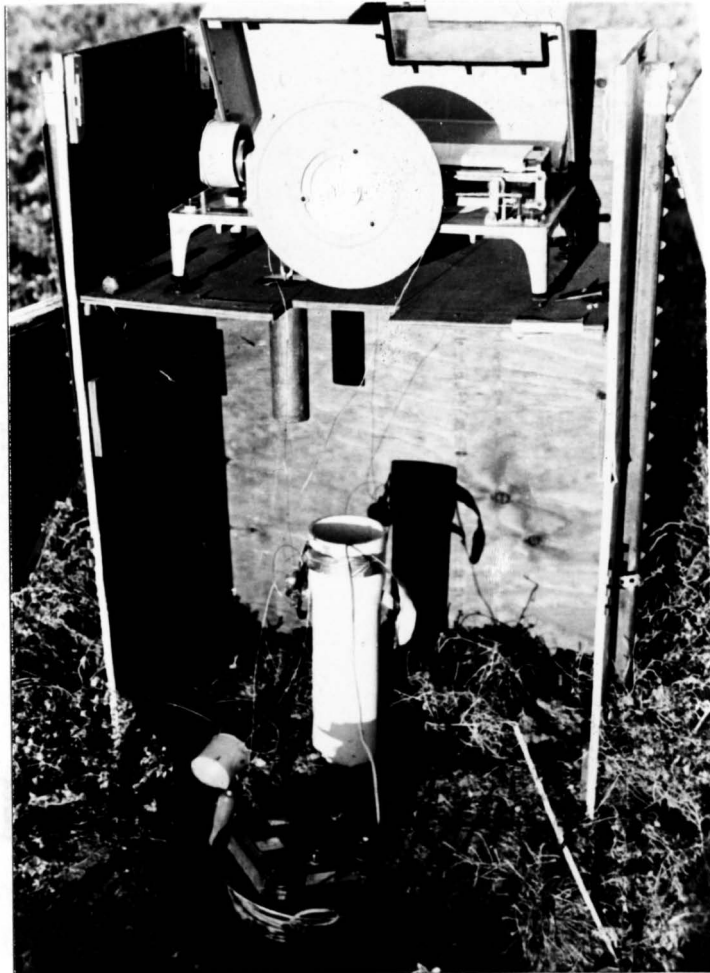

Figure 3. A strip chart recorder logging water fluctuations with time from observation wells near the center of each plot.

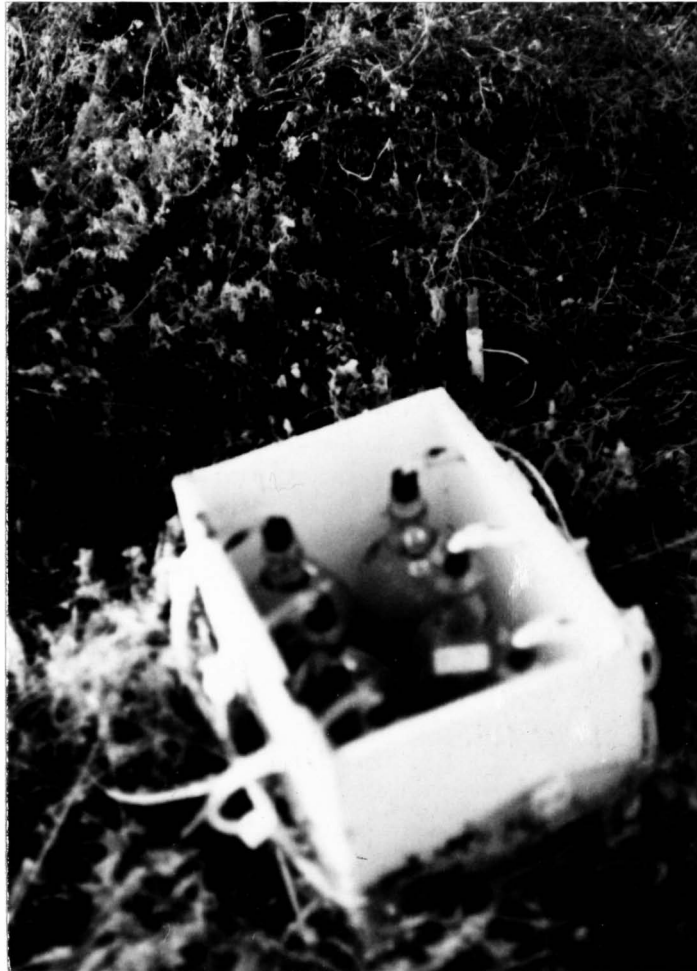

Figure 4. A station of suction tensiometers and evacuated jugs at each plot.

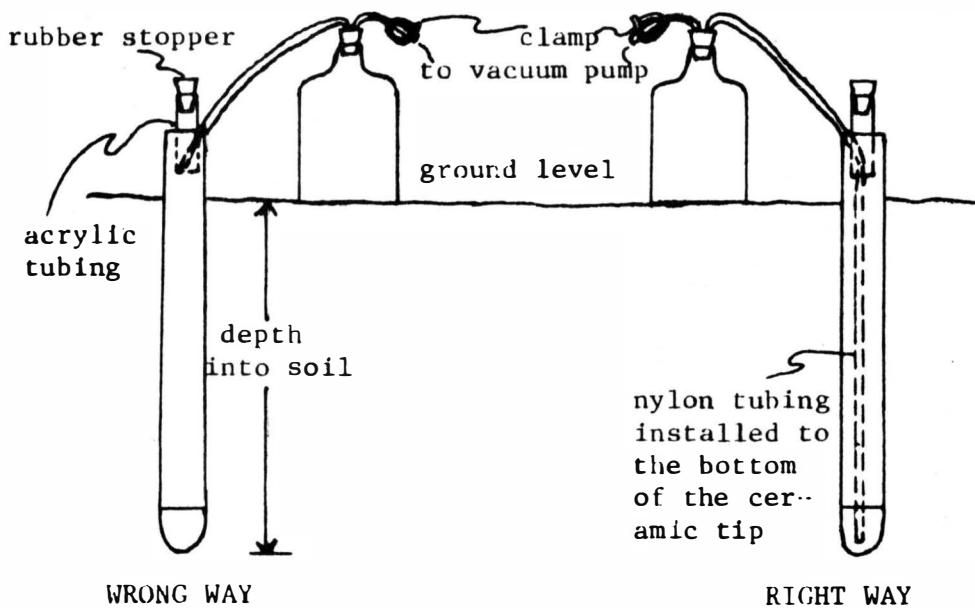

Figure 5. Correct and incorrect way to install the extraction tubing when building a suction tensiometer.

suction tensiometer for the purpose of extracting soil water.

During an irrigation or a rainfall, a downward moving wetting front exists from the beginning of the event when the soil surface usually is near saturation until equilibrium soil tension is reached at a particular depth long after the event has stopped. The rate of movement and the depth of penetration of the water is dependent upon many things such as texture, structure, bulk density, organic matter content, and exchangeable sodium percentage. By using the tensionmeter on the left in Figure 5 during a wetting event water could conceivably move into the ceramic cup with the water level increasing to the point of touching the end of the nylon tube and then move back into the soil through the cup as the soil matrix potential increases during evapotranspiration. While the water level inside the tensiometer is rising, the potential inside the tube is decreasing thereby reducing the pulling

power on the soil across the ceramic tip. Consequently, no water is obtained in the jug. However, if the small nylon "spaghetti" tube were placed to the bottom of the ceramic cup, any water which was pulled into the cup would begin to move immediately to the jug. The two limiting factors for obtaining a water sample under these conditions would be (1) the extent of tension exerted on the tensiometer without pulling in air through the cup and, (2) the depth of the tip relative to the top of the jug.

Because of the configuration used at the left in Figure 5, in situ soil extracts from plot 20 were not obtained simply because of the lower moisture contents and higher soil matrix potentials moving the water out of the tube before it went into the jug. Samples taken on plot 35, 35G, and 50 may have had some diluting occurring from sampling to sampling thereby causing some delay in response to a particularly significant event, however, it did not appear to be a significant problem. Sufficient samples were consistently collected from the other plots. The samples which were collected were collected prior to an irrigation and analyzed in the laboratory for EC, Cl, NO₃, Na, total PO₄, pH, HCO₃ and NH₃.

Wastewater Characteristics

The city of Huron derives its water from the James River. Appendix E shows the James River water quality taken below the dam for the time period of 1980-1982. The water quality fluctuates with precipitation cycles which occur 100-500 km north. The city does partial softening of the water with the addition of unslaked lime (CaO) necessary for the removal of iron and manganese. This contributes to the sodium

hazard associated with applying the water to the soil by reducing the concentration of divalent cations thus increasing the SAR. The specific conductance (EC) of the water varied from 1500 to 3000 $\mu\text{S}/\text{cm}$ as a dry year (1981) followed a normal year and the sodium adsorption ratio (SAR) varied from 5.0 to 11.5. Appendix F shows the numerical values of the various parameters tested in the effluent. Total Kjeldahl nitrogen (TKN) values were 20-24 ppm in the spring dropping to 3-6 ppm in the summer and fall. The nitrate levels peaked out at 3-4.5 ppm about July 1 as the organic and ammonium nitrogen were broken down and volatilized by rising temperatures and increased biological activity. Figures 6, 7 and 8 graphically show the fluctuations with time of the various water quality parameters of EC, Na, sodium adsorption ratio (SAR), adjusted SAR (adjusts for the precipitation of CaCO_3), TKN (total Kjeldahl nitrogen), NO_3 , Cl, alkalinity (MO), alkalinity (P), Ca, Mg, and SO_4 .

Organic and inorganic chemicals were looked at the first year to determine the levels in the lagoon and, if any were found to be high, they would be looked at in the ground water beneath the plots. Table 6 lists the constituents in the water on August 14, 1980. They all were below the maximum EPA contaminant levels for ground water. Because of the high cost involved for analysis of these constituents and the low levels found, it was decided not to look at that aspect of the study.

Agronomic Information

Before the experiment began, the site had a 6-year old established sparse stand of alfalfa. Twenty cm (8 in) of water was applied to all

HURON EFFLUENT WATER QUALITY

— 1980 1981 --- 1982

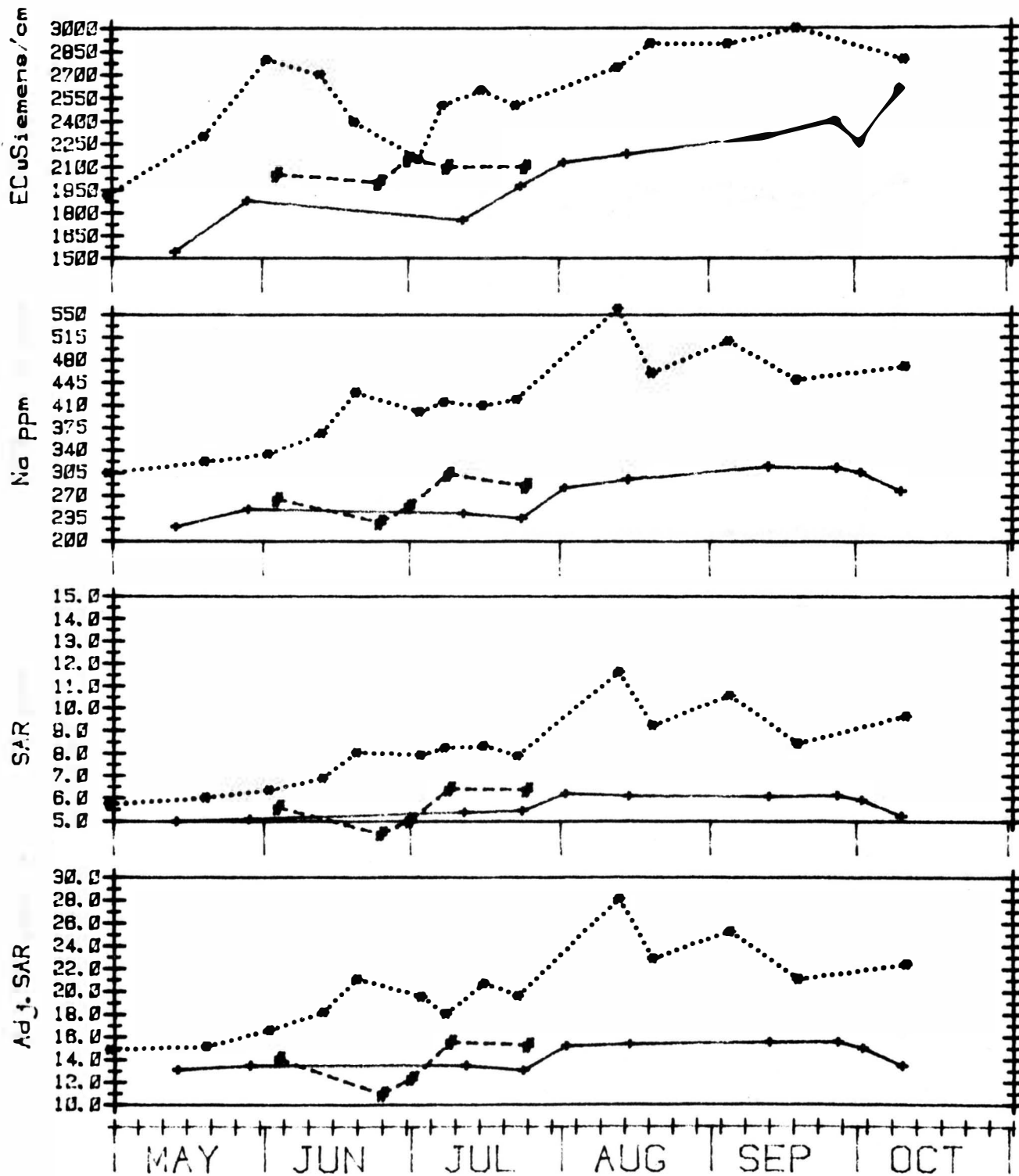

Figure 6. Huron's secondary effluent water quality 1980-1982.

HURON EFFLUENT WATER QUALITY

— 1980 1981 --- 1982

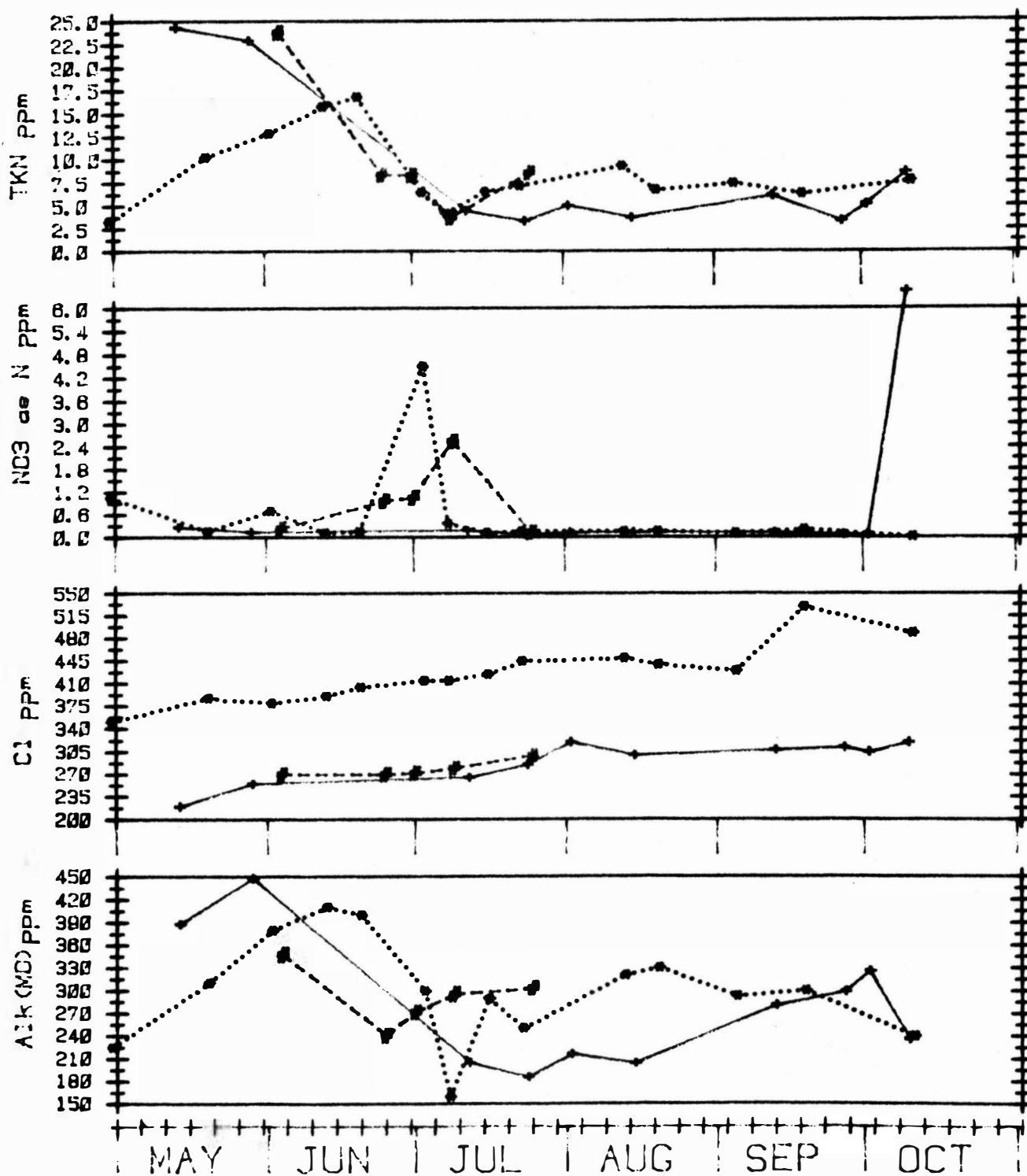

Figure 7. Huron's secondary effluent water quality 1980-1982.

HURON EFFLUENT WATER QUALITY

— 1980 1981 --- 1982

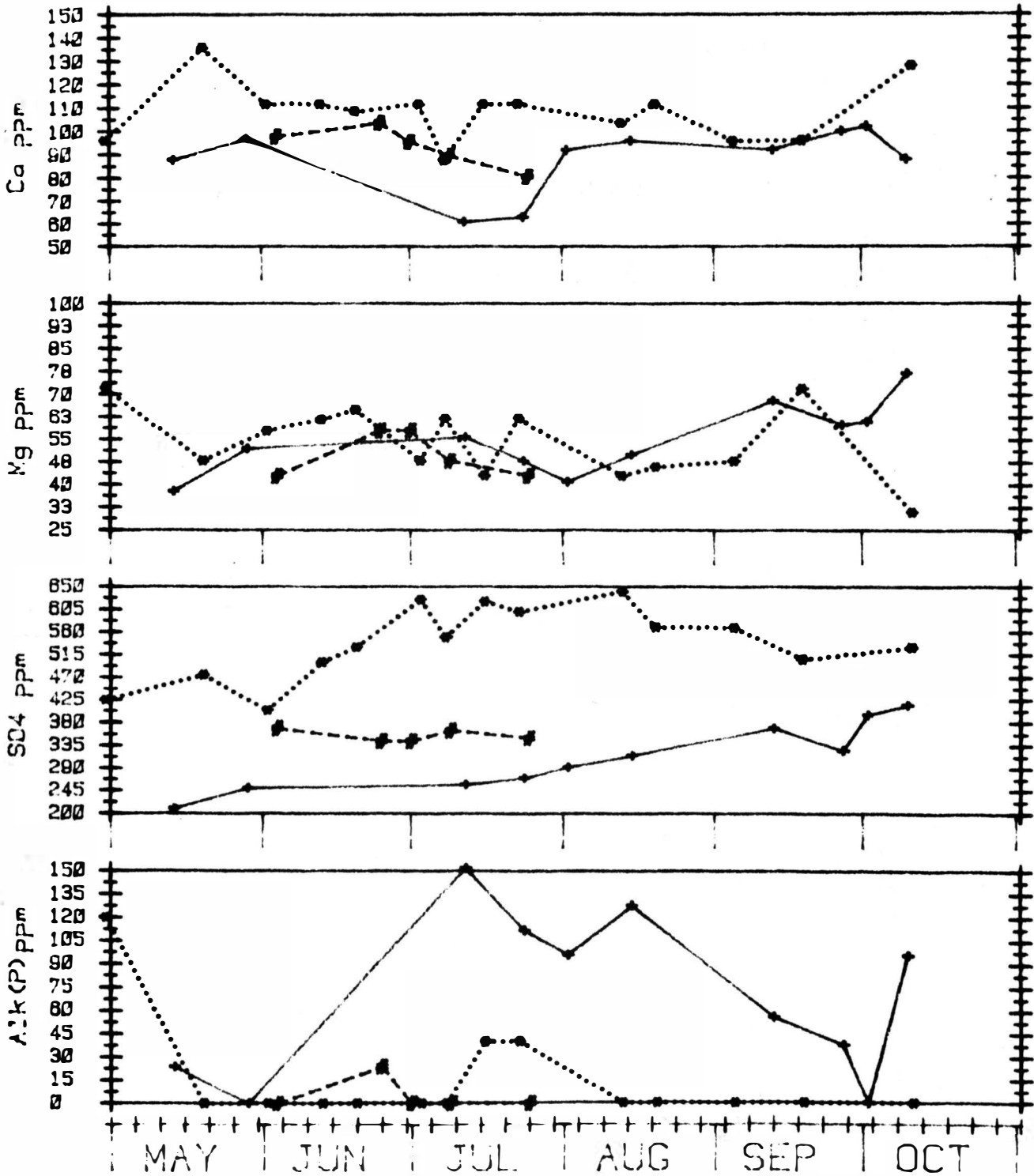

Figure 8. Huron's secondary effluent water quality 1980-1982.

Table 6. Huron effluent organic and inorganic chemical levels as compared to EPA maximum contaminant levels 1980.

| EPA MAXIMUM CONTAMINANT LEVELS FOR ORGANIC CHEMICALS FOR GROUNDWATER | | |
|-------------------------------------------------------------------------|-----------------------|--------------------------------------------|
| | <u>MAXIMUM LIMITS</u> | <u>HURON EFFLUENT VALUES (8/14/80)</u> |
| ENDRIN | .0002 PPM | < .0001* |
| LINDANE | .004 PPM | < .00002* |
| METHOXYCHLOR | .1 PPM | < .0005* |
| TOXAPHENE | .005 PPM | < .001* |
| 2,4-D | .1 PPM | < .1 |
| SILVEX | .01 PPM | < .01 |

*MINIMUM DETECTABLE LIMIT

EPA MAXIMUM CONTAMINANT LEVELS
FOR INORGANIC CHEMICALS FOR GROUNDWATER

| | <u>MAXIMUM LIMITS</u> | <u>HURON EFFLUENT VALUES (8/14/80)</u> |
|-------------|-----------------------|--------------------------------------------|
| ARSENIC | 50 PPB | 13 |
| BARIUM | 1000 PPB | 92 |
| CADMIUM | 10 PPB | < 0.1 |
| CHROMIUM | 50 PPB | 21 |
| LEAD | 50 PPB | < 1 |
| MERCURY | 2 PPB | < 0.5 |
| SELENIUM | 10 PPB | 2 |
| SILVER | 50 PPB | < 1 |
| IRON | --- | 10 |
| NITRATE (N) | 10 PPM | 0.02 |

plots the first two days. This was done to bring the extremely dry soil to normal moisture levels and to possibly stimulate growth of dormant plants. The stand remained unacceptable so after the first harvest a more moisture tolerant variety of alfalfa (Agate) was seeded and quickly established. Irrigations were applied at equal depths across treatments to establish an even stand (Figure 9). Four cuttings were approximately 5 weeks apart with only 3 cuttings in 1981 due to the seeding setback. Table 7 lists the seeding and harvest dates, fertilizers, insecticide, and herbicide for the entire project. A 10-12.5 cm (4-5 in) stubble was left after harvest and a 6.1 meter (20 ft) row sample was weighed and tested for moisture content. Three sites were selected at each harvest on each plot for yield determinations. Soil fertility samples were taken in the fall of 1981 because of increased lodging of plants on the fourth cutting. One hundred fifteen kg/ha of 0-46-0 was recommended and applied in the spring of 1982.

Soil Amendment Rates

Near the end of the 1980 irrigation season, bagged powdered gypsum was obtained from Iowa and applied to the 35G plot. An estimate had to be made of the application rate since soil samples were to be taken after the last irrigation. Therefore, the water analysis and depth of application at each irrigation were used to total up the weight of calcium needed to maintain an SAR_{iw} of less than 5 throughout the season. If the ESP (exchangeable sodium percentage) levels equal the SAR of the irrigation water (SAR_{iw}) near the soil surface when the soil solution is in equilibrium with exchangeable cations, then an SAR, or ESP, of 5 should be an acceptable level to allow in the soil without causing



Figure 9. The experimental plot irrigation system on 35G with new seeding of alfalfa June 1980.

Table 7. Agronomic crop information, 1980-1982.

| | <u>Variety</u> | <u>Seeding date</u> | <u>Harvest dates</u> (11 cm stubble) | <u>Commercial</u> <u>fertilization</u> | <u>Insecticide</u> | <u>Herbicide</u> |
|------|----------------|---------------------|-----------------------------------------|-------------------------------------------|---------------------------|---------------------------------|
| 1980 | Agate | June 11, '80 | June 2 July 16 Aug. 28 | | | 6/10/80 Eptam(6E) (4.5 l/ha) |
| 1981 | | | May 26 July 1 July 27 Sept. 3 | | Furadan 4F (1.17 l/ha) | |
| 1982 | | | June 2 July 8 Aug. 5 Sept. 20 | 6/8/82 0-46-0 (20 kg/ha) | | |

any deterioration of structure or tilth. However, cation exchange capacity, clay mineralogy, organic matter content, structure and irrigation management all play major roles in mitigating the extent of soil dispersion at various ESP levels.

Tables 8, 9, and 10 show the amount of calcium needed to add to the soil to bring the SAR to either 3 or 5. The seasonal calcium requirement was added to the soil near the end of the irrigation season, however, and was not mixed with the water prior to application. This method was tested to determine if removal of potential exchangeable sodium was feasible and effective under this type of annual hydraulic loading.

Based on the seasonal total of calcium required each year from Table 8, gypsum ($\text{CaSO}_4 \cdot 2\text{H}_2\text{O}$) rates were determined by the following method:

$$\frac{\text{Total kg Ca required}}{\text{1 season}} \times \frac{\text{CaSO}_4 \cdot 2\text{H}_2\text{O}(\text{formula wt})}{\text{Ca}(\text{atomic wt})} = \frac{\text{Total kg CaSO}_4 \cdot 2\text{H}_2\text{O}}{\text{required}}$$

For 1980,

$$153.7 \text{ kg Ca} \times \frac{172.2 \text{ gms } (\text{CaSO}_4 \cdot 2\text{H}_2\text{O})}{40.1 \text{ gms } (\text{Ca})} = 660 \text{ kg CaSO}_4 \cdot 2\text{H}_2\text{O}$$

Then, assuming a standard "rule of thumb" of 25% loss of calcium in the replacement reaction for exchangeable sodium below 10%, an efficiency factor must be used to calculate the total weight of pure $\text{CaSO}_4 \cdot 2\text{H}_2\text{O}$ needed for sodium removal. Thus,

$$660 \text{ kg CaSO}_4 \cdot 2\text{H}_2\text{O} \times 1.25 = 825 \text{ kg}$$

Approximately 900 kg of pure $\text{CaSO}_4 \cdot 2\text{H}_2\text{O}$ was applied to the plot with a drop fertilizer spreader on September 4th, 1980. A total of six passes were made with three each direction.

In 1981, the water quality worsened and the SAR increased because

Table 8. Treatment $35G$ calcium requirements (1980) needed to maintain the SAR_{iw} at 3 or 5 based upon the water analysis and depth of water applied at each irrigation during the season. Total calcium requirements for the season are given at the bottom.

| DATE | SAR=3 | | | | SAR=5 | | |
|---------------|-----------------------|---------------------|---------------------|--------------------------|---------------------|---------------------|--------------------------|
| | Effluent Applied (cm) | me/l Ca to be added | kg Ca per ha per cm | kg Ca per plot per irrig | me/l Ca to be added | kg Ca per ha per cm | kg Ca per plot per irrig |
| 800513 | 12.70 | 13.21 | 26.55 | 125.28 | -0.04 | -0.09 | -0.40 |
| 800519 | 9.14 | 13.21 | 26.55 | 90.20 | -0.04 | -0.09 | -0.29 |
| 800528 | 4.32 | 16.96 | 34.08 | 54.69 | 0.29 | 0.58 | 0.93 |
| 800612 | 2.72 | 16.96 | 34.08 | 34.42 | 0.29 | 0.58 | 0.58 |
| 800616 | 2.82 | 16.96 | 34.08 | 35.71 | 0.29 | 0.58 | 0.61 |
| 800620 | 1.78 | 16.96 | 34.08 | 22.52 | 0.29 | 0.58 | 0.38 |
| 800702 | 4.57 | 16.96 | 34.08 | 57.91 | 0.29 | 0.58 | 0.98 |
| 800710 | 3.91 | 17.19 | 34.54 | 50.21 | 1.31 | 2.63 | 3.83 |
| 800722 | 5.33 | 16.13 | 32.43 | 64.28 | 1.29 | 2.59 | 5.12 |
| 800725 | 3.66 | 16.13 | 32.43 | 44.08 | 1.29 | 2.59 | 3.51 |
| 800731 | 4.37 | 25.70 | 51.66 | 83.87 | 4.17 | 8.38 | 13.61 |
| 800805 | 4.01 | 25.70 | 51.66 | 77.05 | 4.17 | 8.38 | 12.50 |
| 800808 | 3.66 | 25.70 | 51.66 | 70.22 | 4.17 | 8.38 | 11.40 |
| 800813 | 5.33 | 27.68 | 55.64 | 110.29 | 4.29 | 8.61 | 17.07 |
| 800822 | 5.69 | 27.68 | 55.64 | 117.64 | 4.29 | 8.61 | 18.21 |
| 800911 | 5.66 | 31.54 | 63.39 | 133.42 | 4.86 | 9.77 | 20.56 |
| 800916 | 5.66 | 31.54 | 63.39 | 133.42 | 4.86 | 9.77 | 20.56 |
| 800925 | 3.71 | 31.26 | 62.84 | 86.59 | 4.92 | 9.90 | 13.64 |
| 800930 | 2.90 | 29.26 | 58.81 | 63.29 | 4.09 | 8.21 | 8.84 |
| 801007 | 2.72 | 21.78 | 43.78 | 44.22 | 1.01 | 2.02 | 2.04 |
| TOTALS | 94.67 | | | 1499.3 | | | 153.7 |

Table 9. Treatment 35G calcium requirements (1981) needed to maintain an SAR_{iw} at 3 or 5 based upon the water analysis and depth of water applied at each irrigation during the season. Total calcium requirements are given at the bottom.

| DATE | SAR=3 | | | | SAR=5 | | |
|---------------|-----------------------|---------------------|---------------------|--------------------------|---------------------|---------------------|--------------------------|
| | Effluent Applied (cm) | me/l Ca to be added | kg Ca per ha per cm | kg Ca per plot per irrig | me/l Ca to be added | kg Ca per ha per cm | kg Ca per plot per irrig |
| 810505 | 5.84 | 28.41 | 57.09 | 123.95 | 3.40 | 6.82 | 14.82 |
| 810513 | 4.50 | 28.41 | 57.09 | 95.38 | 3.40 | 6.82 | 11.40 |
| 810519 | 5.87 | 32.58 | 65.48 | 142.77 | 4.87 | 9.80 | 21.36 |
| 810601 | 4.47 | 36.54 | 73.44 | 121.99 | 6.54 | 13.15 | 21.85 |
| 810608 | 3.86 | 36.54 | 73.44 | 105.36 | 6.54 | 13.15 | 18.87 |
| 810612 | 1.24 | 45.62 | 91.69 | 42.41 | 9.60 | 19.30 | 8.93 |
| 810619 | 4.67 | 66.92 | 134.52 | 233.61 | 17.21 | 34.60 | 60.09 |
| 810626 | 6.78 | 66.92 | 134.52 | 339.00 | 17.21 | 34.60 | 87.19 |
| 810706 | 5.87 | 62.89 | 126.41 | 275.62 | 16.59 | 33.34 | 72.70 |
| 810714 | 5.59 | 61.51 | 123.64 | 256.74 | 16.32 | 32.80 | 68.11 |
| 810811 | 5.28 | 123.03 | 247.30 | 485.51 | 38.72 | 77.83 | 152.80 |
| 810818 | 5.46 | 79.54 | 159.88 | 324.44 | 22.65 | 45.53 | 92.40 |
| 810826 | 3.40 | 79.54 | 159.88 | 202.21 | 22.65 | 45.53 | 57.59 |
| 810917 | 3.66 | 74.39 | 149.53 | 203.24 | 19.95 | 40.10 | 54.50 |
| 810929 | 3.56 | 74.39 | 149.53 | 197.59 | 19.95 | 40.10 | 52.99 |
| TOTALS | 78.11 | | | 3402.6 | | | 859.4 |

Table 10. Treatment 35G calcium requirements (1982) needed to maintain an SAR_{iw} at 3 or 5 based upon the water analysis and depth of water applied at each irrigation during the season. Total calcium requirements are given at the bottom.

| DATE | SAR=3 | | | | SAR=5 | | |
|--------|-----------------------|---------------------|---------------------|--------------------------|---------------------|---------------------|--------------------------|
| | Effluent Applied (cm) | me/l Ca to be added | kg Ca per ha per cm | kg Ca per plot per irrig | me/l Ca to be added | kg Ca per ha per cm | kg Ca per plot per irrig |
| 820608 | 3.20 | 21.10 | 42.40 | 50.43 | 2.22 | 4.46 | 5.30 |
| 820617 | 1.91 | 21.10 | 42.40 | 30.02 | 2.22 | 4.46 | 3.15 |
| 820624 | 2.46 | 12.10 | 24.32 | 22.27 | -2.00 | -4.02 | -3.68 |
| 820630 | 6.38 | 17.57 | 35.32 | 83.68 | 0.23 | 0.46 | 1.08 |
| 820707 | 2.64 | 30.15 | 60.61 | 59.50 | 5.47 | 11.00 | 10.80 |
| 820713 | 1.85 | 30.15 | 60.61 | 41.76 | 5.47 | 11.00 | 7.58 |
| 820723 | 0.79 | 26.57 | 53.40 | 15.62 | 4.73 | 9.50 | 2.78 |
| 820727 | 2.18 | 26.57 | 53.40 | 43.34 | 4.73 | 9.50 | 7.71 |
| 820803 | 4.14 | 23.87 | 47.98 | 73.82 | 2.49 | 5.01 | 7.71 |
| 820810 | 5.33 | 23.38 | 46.99 | 93.14 | 2.90 | 5.83 | 11.55 |
| 820819 | 5.31 | 24.34 | 48.92 | 96.50 | 2.19 | 4.41 | 8.69 |
| 820825 | 3.38 | 23.53 | 47.29 | 59.37 | 2.15 | 4.32 | 5.42 |
| 820903 | 2.18 | 23.53 | 47.29 | 38.39 | 2.15 | 4.32 | 3.50 |
| 820909 | 3.56 | 39.02 | 78.44 | 103.65 | 7.21 | 14.49 | 19.15 |
| TOTALS | 48.69 | | | 870.9 | | | 96.2 |

of low precipitation amounts during the winter and through the summer. Concentrating effects were evident both in the James River and in the stabilization ponds and the calcium requirements accordingly were increased. Table 9 indicates that 860 kg of calcium was needed to counteract the sodium amounts applied. By going through the same calculations above, a season gypsum requirement for the 35G plot was 4600 kg gypsum, much higher than the first year. This "drought" year was not accounted for in the gypsum supply, consequently only 1360 kg gypsum was applied on September 15, 1982 to that plot.

After soil samples were taken in the fall of 1981, results showed quite high exchangeable sodium levels on treatment 20 for all three sites. Consequently, the 20 plot was split in half with the calcium requirements applied to the east half of the plot. Table 11 shows the total calcium requirements per plot for the total season for each year. The amount of $\text{CaSO}_4 \cdot 2\text{H}_2\text{O}$ needed is calculated as follows from Table 11:

$$1980 + 1981 \text{ Ca requirements (kg)} \times \frac{172.2}{40.1} \times 1.25 \times \frac{1}{2} \text{ (half a plot)}$$

$$= \text{total kg } \text{CaSO}_4 \cdot 2\text{H}_2\text{O} / \frac{1}{2} \text{ plot}$$

Then,

$$(572.6 + 88.6) \times \frac{172.2}{40.1} \times 1.25 \times \frac{1}{2} = \underline{1775 \text{ kg } \text{CaSO}_4 \cdot 2\text{H}_2\text{O}}$$

The amount applied to the split 20 plot amounted to 1680 kg $\text{CaSO}_4 \cdot 2\text{H}_2\text{O}$ which was somewhat short. However, it was desirable to see how effective a heavier one time application was in lowering the ESP below 15% which was present at the top 30 cm.

Table 11. Treatment 20 calcium requirements (1980 and 1981) to maintain the SAR_{iw} at 3 or 5 based upon the water analysis and depth of water applied at each irrigation during the season. Total calcium requirements for the season are given at the bottom of each year.

| DATE | SAR=3 | | | | SAR=5 | | |
|---------------|-----------------------|---------------------|---------------------|--------------------------|---------------------|---------------------|--------------------------|
| | Effluent Applied (cm) | me/l Ca to be added | kg Ca per ha per cm | kg Ca per plot per irrig | me/l Ca to be added | kg Ca per ha per cm | kg Ca per plot per irrig |
| 800513 | 12.70 | 13.21 | 26.55 | 125.28 | -0.04 | -0.09 | -0.40 |
| 800519 | 8.13 | 13.21 | 26.55 | 80.18 | -0.04 | -0.09 | -0.26 |
| 800528 | 2.03 | 16.96 | 34.08 | 25.74 | 0.29 | 0.58 | 0.44 |
| 800612 | 2.72 | 16.96 | 34.08 | 34.42 | 0.29 | 0.58 | 0.58 |
| 800616 | 2.82 | 16.96 | 34.08 | 35.71 | 0.29 | 0.58 | 0.61 |
| 800620 | 1.78 | 16.96 | 34.08 | 22.52 | 0.29 | 0.58 | 0.38 |
| 800702 | 3.05 | 16.96 | 34.08 | 38.60 | 0.29 | 0.58 | 0.65 |
| 800710 | 2.39 | 17.19 | 34.54 | 30.65 | 1.31 | 2.63 | 2.34 |
| 800722 | 3.05 | 16.13 | 32.43 | 36.73 | 1.29 | 2.59 | 2.93 |
| 800725 | 2.39 | 16.13 | 32.43 | 28.77 | 1.29 | 2.59 | 2.29 |
| 800731 | 2.54 | 25.70 | 51.66 | 48.76 | 4.17 | 8.38 | 7.91 |
| 800805 | 2.44 | 25.70 | 51.66 | 46.81 | 4.17 | 8.38 | 7.60 |
| 800808 | 2.13 | 25.70 | 51.66 | 40.96 | 4.17 | 8.38 | 6.65 |
| 800813 | 3.05 | 27.68 | 55.64 | 63.02 | 4.29 | 8.61 | 9.76 |
| 800822 | 3.28 | 27.68 | 55.64 | 67.75 | 4.29 | 8.61 | 10.49 |
| 800911 | 3.05 | 31.54 | 63.39 | 71.79 | 4.86 | 9.77 | 11.06 |
| 800916 | 3.15 | 31.54 | 63.39 | 74.19 | 4.86 | 9.77 | 11.43 |
| 800925 | 2.18 | 31.26 | 62.84 | 51.01 | 4.92 | 9.90 | 8.03 |
| 800930 | 1.60 | 29.26 | 58.81 | 34.97 | 4.09 | 8.21 | 4.88 |
| 801007 | 1.57 | 21.78 | 43.78 | 25.62 | 1.01 | 2.02 | 1.18 |
| TOTALS | 66.04 | | | 983.5 | | | 88.6 |
| 810505 | 3.45 | 28.41 | 57.09 | 73.29 | 3.40 | 6.82 | 8.76 |
| 810513 | 2.34 | 28.41 | 57.09 | 49.58 | 3.40 | 6.82 | 5.93 |
| 810519 | 3.56 | 32.58 | 65.48 | 86.53 | 4.87 | 9.80 | 12.95 |
| 810601 | 2.59 | 36.54 | 73.44 | 70.70 | 6.54 | 13.15 | 12.66 |
| 810608 | 2.92 | 36.54 | 73.44 | 79.71 | 6.54 | 13.15 | 14.28 |
| 810619 | 2.77 | 66.92 | 134.52 | 138.39 | 17.21 | 34.60 | 35.59 |
| 810626 | 3.05 | 66.92 | 134.52 | 152.36 | 17.21 | 34.60 | 39.19 |
| 810706 | 3.58 | 62.89 | 126.41 | 168.24 | 16.59 | 33.34 | 44.38 |
| 810714 | 3.30 | 61.51 | 123.64 | 151.71 | 16.32 | 32.80 | 40.25 |
| 810721 | 3.05 | 63.45 | 127.53 | 144.45 | 16.02 | 32.21 | 36.48 |
| 810811 | 3.00 | 123.03 | 247.30 | 275.43 | 38.72 | 77.83 | 86.69 |
| 810818 | 3.18 | 79.54 | 159.88 | 188.63 | 22.65 | 45.53 | 53.72 |
| 810826 | 1.88 | 79.54 | 159.88 | 111.67 | 22.65 | 45.53 | 31.80 |
| 810917 | 2.21 | 74.39 | 149.53 | 122.79 | 19.95 | 40.10 | 32.93 |
| 810929 | 2.03 | 74.39 | 149.53 | 112.91 | 19.95 | 40.10 | 30.28 |
| TOTALS | 45.90 | | | 2201.8 | | | 572.6 |

At the same time, past irrigation management on the 20 plot was limited to weekly applications of 1.7-3.4 cm (.7-1.4 in) per irrigation with the depth dependent upon ET demands. This was contrary to the most efficient use of the water and apparently concentrated much of the sodium applied in the top foot of soil. Therefore, the irrigation schedule on the 20 and 20G plot for 1982 was changed to irrigate every third week with three times the depth of application. This regime was more desirable for prevention of sodium accumulations near the surface, however, it was contrary to the best management for sodium reclamation (18). During this type of experiment, water has to be disposed of yet sodium has to be removed from the exchange complex while trying to minimize exchangeable sodium.

Upon project completion, numerous undisturbed soil cores at the 0-3 cm depth were collected from all treatments including surrounding checks on unirrigated areas to determine if ESP (exchangeable sodium percentages) correlated with reduced saturated hydraulic conductivities. A Eulen core sampler (with brass ring inserts), which uses 3 cm by 5.4 cm ID brass sleeves, was used to take the samples within the boundaries of the sprinkler heads. A petroleum jelly was used to coat the inside of the rings prior to sampling to prevent compaction during sampling and channeling during testing.

A constant rate peristaltic pump was used to move deionized water through the cores which were placed inside acrylic Tempe cells similar to the one shown in Figure 10. Polyethylene filters with 35 micron openings were used in place of the ceramic plates. Twenty-four cores were tested at the same time with each channel of the pump delivering

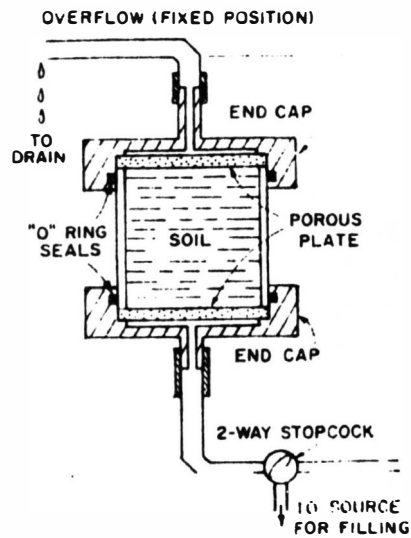

Figure 10. Representation of the design of acrylic Tempe cell used to hold undisturbed soil cores for saturated hydraulic conductivity measurements. (Taken from Methods of Soil Analysis, Agronomy Monograph No. 9, page 218.)

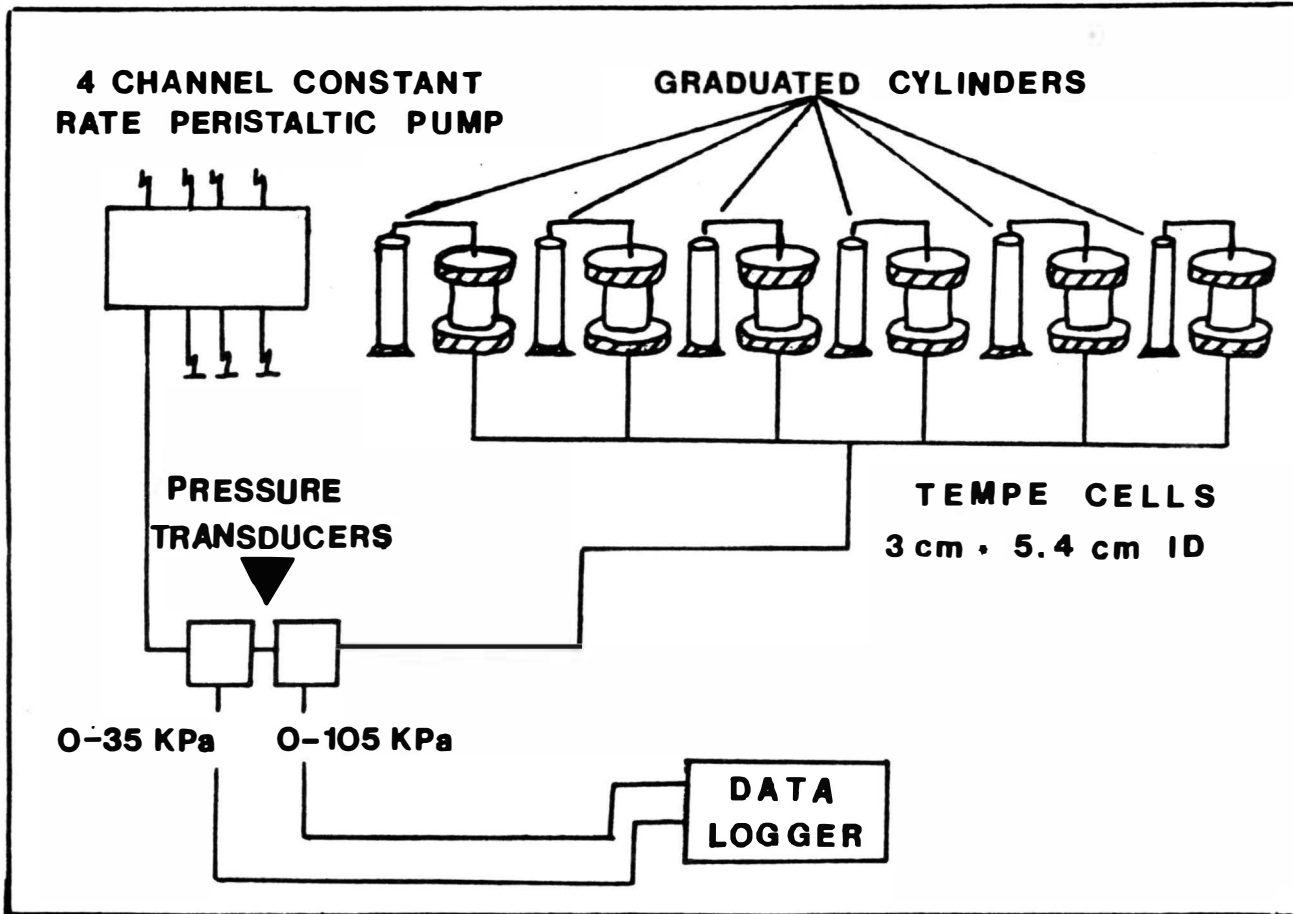

Figure 11. Schematic representation of the design used in measuring saturated hydraulic conductivities.

water simultaneously to six cores (Figure 11). Piezoresistive pressure transducers were used to monitor the pressure head while the delivery rate was kept constant by the pump. Graduated cylinders were used to measure hourly volumes and a subsequent $K(\theta_s)$ value was calculated. The test was conducted for six hours and the six $K(\theta_s)$ values were averaged for each core. Darcy's law,

$$V = -K \frac{h}{L}$$

where V = velocity of flow, cm/hr

K = hydraulic conductivity, cm/hr

h/L = potential gradient, cm/cm

was used to calculate the K value. By rearranging the above terms

$$K = - \frac{qL}{ah}$$

where q = volume collected in time t , cm^3

a = cross-sectional area of core, cm^2

h = pressure head, cm

L = length of core, cm

and the hydraulic conductivity could then be calculated.

RESULTS AND DISCUSSION

Forage Yields

The dry matter alfalfa yields for the treatments by year and replication are given in Appendix H. The average treatment yields per cutting are given in Table 12. There was a significant difference in yield every year among the treatments at the .01 level. However, this was contributed entirely by the check plot as is evident in Table 13. Single degree of freedom comparisons were used to identify differences in mean yields. However, only the 20 plot in 1981 showed any significant (.05 level) difference from the other treatments. This was due to the shortage of rainfall throughout the season and total moisture fell below ET demands. Statistically, there were no significant yield differences caused by varying the annual hydraulic loading from 50 cm to 127 cm except during an exceptionally dry year (1981).

The extra increase in dry matter yield over the check due to irrigation varied from 1615 kg/ha (.72 ton/acre) per cutting for the 20 plot average to 1856 kg/ha (.83 tons/acre) per cutting for the 35 and 35G plot averages. Assuming four cuttings per year that relates to a range of 6460 kg/ha-7424 kg/ha (2.88-3.31 tons/acre) for alfalfa dry matter yield increases. At \$55/1000 kg (\$50/ton) that would amount to \$355-\$408/ha (\$144-\$165/acre) increase in gross revenues.

Water table problems showed up at the end of the second year in both the 50 and 35G plots. Loss of alfalfa plants began at that time on the 50 plot. By the end of the third year a 15-20% reduction in alfalfa plants had occurred near the east lower end of the plot

Table 12. Moisture and yield data of alfalfa plots 1980-1982, dry matter.

| Treatment | Year | Cumulative rainfall cm(in)* | Cumulative irrigation cm(in) | Total cm(in) | Seasonal ET, cm(in) | ΔStorage plus leaching+RO cm(in) | Average per cutting yield kg/ha(tons/A) |
|-----------|------|--------------------------------|---------------------------------|-----------------|------------------------|----------------------------------------|-----------------------------------------------|
| 50 | 1980 | 40 (15.6) | 120 (47.1) | 160 (62.7) | 77 (30.3) | 82 (32.3) | 2179 (0.97) |
| | 1981 | 27 (10.5) | 108 (42.5) | 135 (53.0) | 76 (29.8) | 59 (23.1) | 2696 (1.20) |
| | 1982 | 48 (19.0) | 78 (30.9) | 126 (49.9) | 76 (29.9) | 51 (19.9) | 2606 (1.16) |
| | Avg. | 38 (15.0) | 102 (40.2) | 140 (55.2) | 76 (30.0) | -- -- | 2516 (1.12) |
| 35G | 1980 | 40 (15.6) | 95 (37.3) | 135 (52.9) | 77 (30.3) | 57 (22.5) | 2471 (1.10) |
| | 1981 | 27 (10.5) | 75 (29.7) | 102 (40.2) | 76 (29.8) | 26 (10.3) | 2471 (1.10) |
| | 1982 | 48 (19.0) | 45 (17.8) | 93 (36.8) | 76 (29.9) | 18 (6.9) | 2808 (1.25) |
| | Avg. | 36 (15.0) | 72 (28.3) | 110 (43.3) | 76 (30.0) | -- -- | 2577 (1.15) |
| 35 | 1980 | 40 (15.6) | 94 (36.9) | 134 (52.5) | 77 (30.3) | 56 (22.2) | 2224 (0.99) |
| | 1981 | 27 (10.5) | 75 (29.7) | 102 (40.2) | 76 (29.8) | 26 (10.3) | 2696 (1.20) |
| | 1982 | 48 (19.0) | 45 (17.8) | 93 (36.8) | 76 (29.9) | 18 (6.9) | 2741 (1.22) |
| | Avg. | 38 (15.0) | 71 (28.1) | 110 (43.2) | 76 (30.0) | -- -- | 2579 (1.15) |
| 20 | 1980 | 40 (15.6) | 66 (26.0) | 106 (41.6) | 77 (30.3) | 29 (11.3) | 2134 (0.95) |
| | 1981 | 27 (10.5) | 43 (16.9) | 70 (27.4) | 76 (29.8) | -6 (-2.5) | 2246 (1.00) |
| | 1982 | 48 (19.0) | 27 (10.5) | 75 (29.5) | 76 (29.9) | -1 (-0.4) | 2673 (1.19) |
| | Avg. | 38 (15.0) | 45 (17.8) | 84 (32.8) | 76 (30.0) | -- -- | 2338 (1.04) |
| Check | 1980 | 40 (15.6) | 0 (0.0) | -- -- | 77 (30.3) | -37 (-14.8) | 1235 (0.55) |
| | 1981 | 27 (10.5) | 0 (0.0) | -- -- | 76 (29.8) | -49 (-19.4) | 0 (0.00) |
| | 1982 | 48 (19.0) | 0 (0.0) | -- -- | 76 (29.9) | -28 (-10.9) | 899 (0.40) |
| | Avg. | 38 (15.0) | 0 (0.0) | -- -- | 76 (30.0) | -- -- | 723 (0.32) |
| 20G | 1982 | 48 (19.0) | 27 (10.5) | 75 (29.5) | 76 (29.9) | -1 (-0.4) | 2336 (1.04) [†] |

*May 1 → October 31

†Based on last three cuttings, 1982.

RO=run-off

Table 13. Single degree of freedom partitions of treatment sum of squares for alfalfa yields (kg/ha), 1980-1982.

| | <u>Partition</u> | <u>DF</u> | <u>SS</u> | <u>MS</u> | <u>F</u> |
|--------------|------------------------------------|-----------|-----------|-----------|-----------|
| 1980 | TREATMENT | 4 | 3661.0 | 921.0 | 6.87 ** |
| (3 cuttings) | 50 vs (35+35G+20) | 1 | 38.0 | 38.0 | 0.29 |
| | 35 vs (35G+20+50) | 1 | 2.2 | 2.2 | 0.02 |
| | 35G vs (20+35+50) | 1 | 276.0 | 276.0 | 2.07 |
| | 20 vs (35+50+35G) | 1 | 78.0 | 78.0 | 0.59 |
| | Check vs (35+50+35G+20) | 1 | 3369.0 | 3369.0 | 25.21 ** |
| | ERROR | 40 | 5346.0 | 133.7 | |
| 1981 | TREATMENT | 4 | 27944.0 | 6986.0 | 70.56 ** |
| (4 cuttings) | 50 vs (35+35G+20) | 1 | 193.0 | 193.0 | 1.95 |
| | 35 vs (35G+20+50) | 1 | 225.0 | 225.0 | 2.27 |
| | 35G vs (20+50+35) | 1 | 25.0 | 25.0 | 0.25 |
| | 20 vs (50+35+35G) | 1 | 571.0 | 571.0 | 5.77 * |
| | Check vs (50+35+35G+20) | 1 | 27183.0 | 27183.0 | 275.02 ** |
| | ERROR | 55 | 5436.0 | 98.8 | |
| 1982 | TREATMENT | 4 | 14255.0 | 3565.0 | 25.69 ** |
| (4 cuttings) | 50 vs (35+35G+20) | 1 | 61.0 | 61.0 | 0.82 |
| | 35 vs (35G+20+50) | 1 | 7.0 | 7.0 | 0.09 |
| | 35G vs (20+50+35) | 1 | 67.0 | 67.0 | 0.91 |
| | 20 vs (50+35+35G) | 1 | 9.0 | 9.0 | 0.12 |
| | Check vs (50+35+35G+20) | 1 | 14150.0 | 14150.0 | 190.91 ** |
| | 20G vs (50+35+35G+20) [†] | 1 | 74.0 | 74.0 | 0.98 |
| | ERROR | 55 | 7629.0 | 139.0 | |
| TOTAL | TREATMENT | 4 | 41063.0 | 10266.0 | 66.04 ** |
| (Based on | 50 vs (35+35G+20) | 1 | 0.2 | 0.2 | 0.001 |
| first 3 | 35 vs (35G+20+50) | 1 | 94.0 | 94.0 | 0.61 |
| cuttings) | 35G vs (20+50+35) | 1 | 115.0 | 115.0 | 0.74 |
| | 20 vs (50+35+35G) | 1 | 436.0 | 436.0 | 2.80 |
| | Check vs (50+35+35G+20) | 1 | 40587.0 | 40587.0 | 261.15 ** |
| | ERROR | 160 | 24867.0 | 155.0 | |

*Significant at the .05 level.

**Significant at the .01 level.

[†]Based on last three cuttings of 1982.

(Figure 12). This was caused by either reduced aeration caused by saturation or disease brought about by saturation or both. It was evident on all plots that as local surface water movement increased due to reduced infiltration and/or saturated soils, depressional areas and border soils received increased water amounts. If the project were to be continued with the same hydraulic loading rates, the 50 plot would certainly further decline in yield because of continued alfalfa plant losses. In 1982, treatment 50 was the only plot which showed a decline in yield; however, it was not significant. All other treatments increased in yield from the previous year.

Treatment 35G did show signs of potential alfalfa plant reductions with yellowing of plants in a plow furrow the length of the plot (Figure 13.). Local water movement caused increased amounts of moisture applied to the lower area. The water table was within .9 meters (2.9 ft) of the surface at that time according to the neutron access tube.

Effects of Gypsum Amendments

As mentioned earlier, the amendment required for treatment 35G in 1980 was applied in September 1980. The effects of that application would be seen at the following soil sampling and analysis (fall 1981), if one were to look at annual effects only. However, suction tensiometers were used throughout the irrigation season to extract soil water samples in addition to soil sampling. Figure 14 is a graphical representation of the concentrations of soluble sodium for 1981 on plot 35G. If gypsum is effective in removing sodium from the exchange complex over the winter and spring months, an increase in the soluble sodium concentration should occur and be evident in the early part of

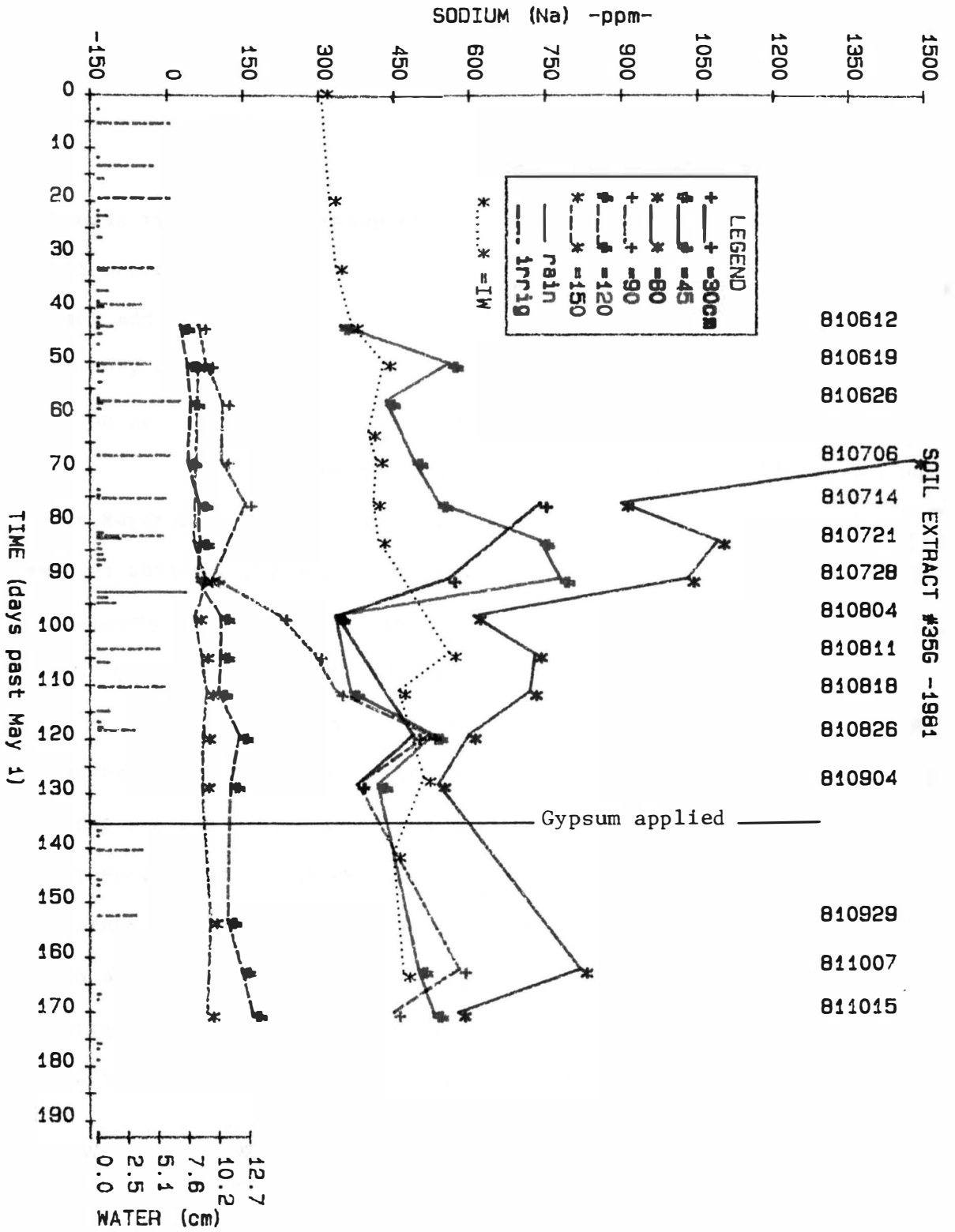

Figure 12. Depiction of the alfalfa population reduction at the low end of the 50 plot August 1982.



Figure 13. A 1982 picture of 35G plot before harvest. A plow furrow running the length of the plot accumulated localized run-off and created the yellowing of the alfalfa. The water table was approximately 1.3 meters below the surface according to the observation well.

Figure 14. Soluble sodium levels with time and depth from plot 35G, 1981.



the following season. July 6, 1981 was the earliest date that soil extract samples were obtained from the 30 and 45 cm depths and they both show sodium levels higher than in the other treatments on that date (Figures 14 and 15). As irrigation amounts increased over the season, sodium levels at the 30, 45, and 60 cm depths decreased while the sodium at the 90 cm depth increased. There appeared to be no change in the sodium level at the 120 and 150 cm depth for 1981. It would appear that as the SAR_{iw} increased and the cumulative irrigations increased, the soluble sodium moved from the upper layers and was deposited into the 90 cm depth. Numerical values of the concentrations are presented in Appendixes A, B and C for the 3 years.

Soluble sodium concentrations gradually increased at the 30, 45, and 60 cm depths for all treatments in 1980. However, the concentrations at the deeper depths all remained fairly low and constant for the first year (Figure 16). Apparently most of the sodium is staying in the top meter, at least for the first two seasons.

Plot 20 for 1980 displayed an exception to this at the 150 cm depth with 690-2360 ppm sodium near the end of the irrigation season. A one-time sample in November from the 20 plot showed 12,200 ppm soluble sodium in the top 30 cm. This small amount of evidence indicates that light infrequent irrigation amounts can be devastating to soil structure by concentrating the applied sodium near the surface.

For 1981, on treatment 35G, EC, chloride, and sodium trends show much the same pattern for the 30, 45, and 60 cm depths. This indicates that a large portion of the cations and anions contributing to the salt load are sodium and chloride. However, for the 90, 120, and 150 cm

Figure 15. Soluble sodium levels with time and depth from plot 50, 1981.

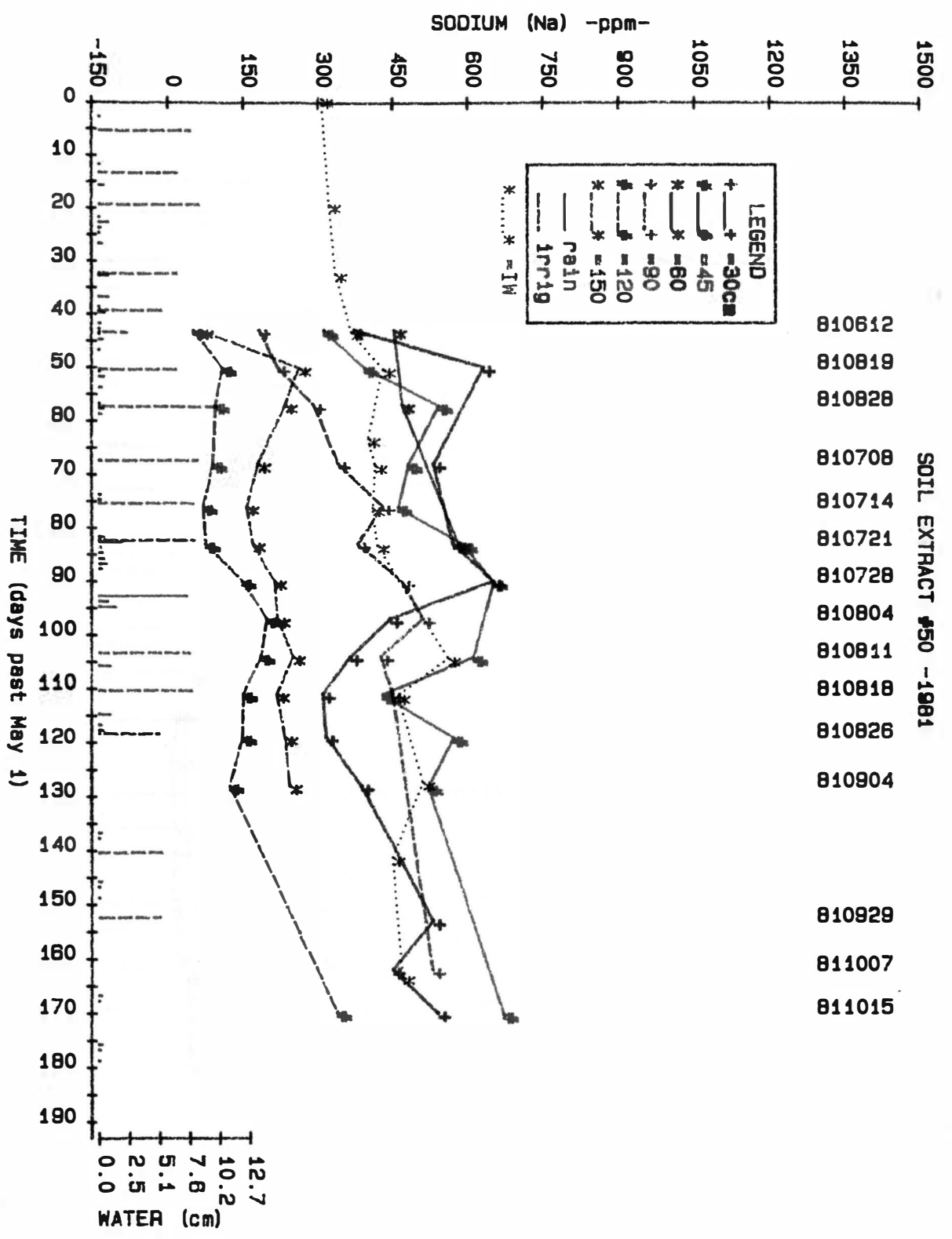

- 810612
- 810819
- 810828
- 810708
- 810714
- 810721
- 810728
- 810804
- 810811
- 810818
- 810826
- 810904
- 810929
- 811007
- 811015

SOIL EXTRACT #50 --1981

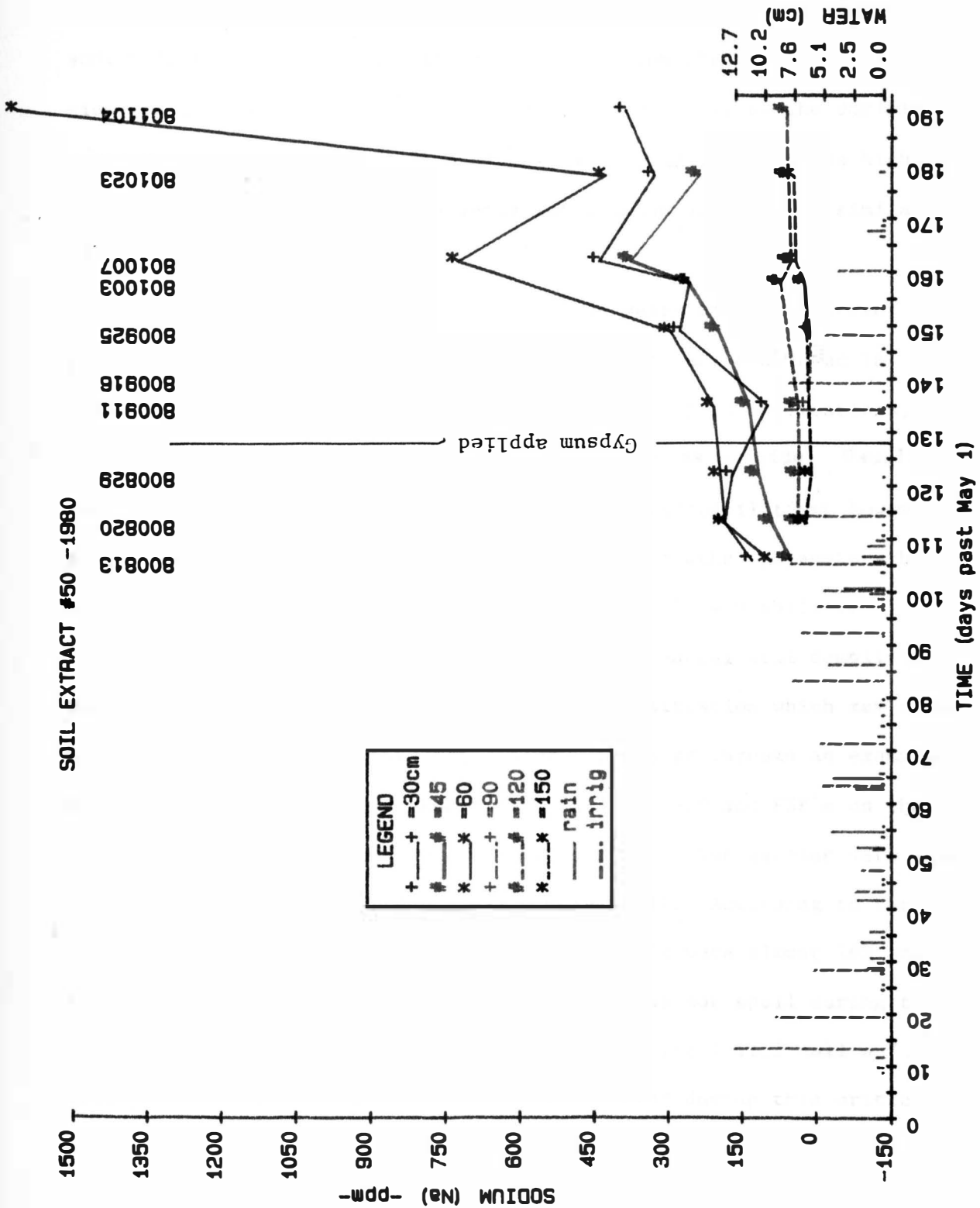

Figure 16. Soluble sodium field extracts by depth from plot 50, 1980.

depth, it's another story. Chloride seems to be the major anion, but sodium is not the dominant cation. Calcium from the gypsum and magnesium (exchanged for calcium on the soil complex) must be the dominant cations. In observation well analyses, magnesium is 4-9 times higher in the 35G over the other treatments but calcium seems to be similar to the other plots (Appendix G).

Soil sampling analyses for the various years on the different plots are averaged for three sites per treatment and presented in Table 14. In determining the effectiveness of gypsum applications, the exchangeable sodium percentage (ESP) is used as a guide. Usually, increasing the ESP will cause decreasing soil permeabilities; however, more research is needed to determine what effect other parameters have on causing a significant realistic change of soil permeability.

It must be understood that annual or semi-annual soil samplings may not be sufficient to determine a critical situation which may occur in the soil during an irrigation season. Let's go through an example. Suppose soil samples were taken in the fall of 1980 and ESP's on the 20 plot at the 30 cm depth were 6.7% (Table 14). Then samples were again taken in the spring of 1982 and ESP's were 11.1%. According to the soil samples taken in the fall of 1982 the ESP's were almost 16% and they may have been higher yet after a particular hot spell during the wetting and drying cycle of that summer, something I will call a "critical period". Soil dispersion may have occurred during this critical period with soil clay particles moving downward to eventually clog pore spaces and reduce permeabilities. The ESP may have approached 20 or even 40 for that interval which caused the damage, however, the only

Table 14. Chemical soil analysis 1980-1982. Average of 2-3 sites per plot per depth.

| Treatment | Depth cm | CEC (me/100g) | | | | | Exchangeable Na (me/100g) | | | | | ESP | | | | | SAR of soil solution | | | | |
|-----------|-------------|---------------|------|------|------|------|---------------------------|-----|-----|-----|-----|-----|-----|------|------|------|----------------------|-----|-----|-----|-----|
| | | 1* | 2 | 3 | 4 | 5 | 1 | 2 | 3 | 4 | 5 | 1 | 2 | 3 | 4 | 5 | 1 | 2 | 3 | 4 | 5 |
| 20 | 0-3 | | | | | 24.6 | | | | | 1.0 | | | | | 4.1 | | | | | 2.3 |
| | 0-15 | | | | 21.6 | 22.4 | | | | 2.4 | 1.5 | | | | 11.0 | 6.9 | | | | 6.1 | 6.2 |
| | 15-30 | | | | 23.5 | 23.0 | | | | 2.6 | 2.3 | | | | 11.2 | 10.1 | | | | 7.5 | 6.2 |
| | 0-30 | 19.8 | 21.2 | 20.2 | | | 0.4 | 1.4 | 3.2 | | | 2.1 | 6.7 | 15.7 | | | 1.4 | 3.5 | 6.2 | | |
| | 30-60 | 19.0 | 15.6 | 18.6 | | 19.0 | 0.2 | 0.5 | 1.5 | | 1.4 | 1.1 | 3.3 | 7.8 | | 7.6 | 1.1 | 0.4 | 2.3 | | 5.2 |
| | 60-90 | 14.1 | 11.5 | 13.5 | | 14.0 | 0.4 | 0.5 | 1.6 | | 0.7 | 2.9 | 4.0 | 11.8 | | 5.1 | 1.5 | 0.9 | 1.4 | | 2.1 |
| 90-120 | 13.7 | 14.1 | 13.9 | | 13.5 | 0.5 | 1.1 | 1.1 | | 0.7 | 3.4 | 8.1 | 8.1 | | 5.3 | 1.6 | 2.5 | 2.2 | | 1.5 | |
| 35 | 0-3 | | | | | 21.0 | | | | | 1.2 | | | | | 5.8 | | | | | 3.6 |
| | 0-15 | | | | 19.7 | 21.5 | | | | 1.8 | 1.6 | | | | 8.8 | 7.3 | | | | 6.0 | 5.4 |
| | 15-30 | | | | 19.9 | 21.3 | | | | 2.1 | 1.7 | | | | 10.7 | 8.2 | | | | 6.7 | 7.0 |
| | 0-30 | 17.5 | 18.7 | 18.3 | | | 0.5 | 1.3 | 1.7 | | | 3.0 | 7.1 | 9.2 | | | 2.4 | 4.3 | 7.8 | | |
| | 30-60 | 15.0 | 15.5 | 15.2 | | 17.7 | 0.1 | 0.5 | 1.4 | | 1.7 | 0.8 | 3.2 | 9.3 | | 9.4 | 0.5 | 1.3 | 6.5 | | 7.7 |
| | 60-90 | 11.7 | 12.8 | 12.7 | | 12.0 | 0.1 | 0.4 | 0.8 | | 1.9 | 1.1 | 3.5 | 6.3 | | 15.8 | 0.4 | 1.0 | 2.7 | | 4.9 |
| 90-120 | 13.9 | 17.0 | 14.8 | | 13.9 | 0.3 | 0.6 | 0.6 | | 1.0 | 1.9 | 3.5 | 4.3 | | 7.0 | 0.5 | 1.6 | 0.8 | | 2.3 | |
| 35G | 0-3 | | | | | 25.1 | | | | | 1.0 | | | | | 4.0 | | | | | 4.0 |
| | 0-15 | | | | 21.4 | 21.0 | | | | 1.6 | 1.6 | | | | 7.4 | 7.5 | | | | 5.3 | 4.7 |
| | 15-30 | | | | 20.8 | 20.8 | | | | 2.2 | 1.9 | | | | 10.5 | 9.0 | | | | 6.6 | 5.8 |
| | 0-30 | 19.6 | | 19.6 | | | 0.4 | | 2.2 | | | 2.3 | | 11.0 | | | 1.6 | | 6.8 | | |
| | 30-60 | 18.4 | | 18.4 | | 19.6 | 0.2 | | 1.3 | | 1.7 | 1.3 | | 6.9 | | 8.9 | 0.4 | | 5.6 | | 6.1 |
| | 60-90 | 13.5 | 16.8 | 13.5 | | 17.8 | 0.4 | 0.3 | 0.7 | | 1.6 | 2.9 | 1.6 | 5.3 | | 9.3 | 1.0 | 0.5 | 3.5 | | 4.5 |
| 90-120 | 16.2 | | 12.9 | | 12.9 | 1.3 | | 0.5 | | 1.0 | 7.9 | | 4.0 | | 8.1 | 2.4 | | 0.9 | | 3.2 | |
| 50 | 0-3 | | | | | 22.0 | | | | | 1.5 | | | | | 6.8 | | | | | 5.6 |
| | 0-15 | | | | 21.9 | 22.2 | | | | 1.9 | 1.7 | | | | 8.4 | 7.7 | | | | 6.2 | 5.6 |
| | 15-30 | | | | 20.0 | 19.3 | | | | 2.2 | 2.0 | | | | 11.0 | 10.2 | | | | 6.8 | 6.8 |
| | 0-30 | 17.5 | 18.4 | 17.9 | | | 0.8 | 1.5 | 1.8 | | | 4.6 | 7.9 | 10.2 | | | 3.3 | 5.1 | 7.9 | | |
| | 30-60 | 16.6 | 11.2 | 13.9 | | 17.0 | 0.4 | 0.6 | 1.4 | | 1.7 | 2.3 | 5.4 | 9.8 | | 10.0 | 0.7 | 2.9 | 7.9 | | 7.1 |
| | 60-90 | 10.3 | 10.5 | 10.4 | | 16.0 | 0.2 | 0.4 | 1.0 | | 1.4 | 1.6 | 4.0 | 10.0 | | 8.9 | 0.4 | 1.3 | 4.6 | | 6.3 |
| 90-120 | 12.6 | 12.9 | 12.7 | | 17.5 | 0.2 | 0.2 | 0.6 | | 1.8 | 1.2 | 1.8 | 4.8 | | 10.4 | 0.3 | 0.5 | 4.2 | | 5.0 | |
| 20G | 0-3 | | | | | 24.6 | | | | | 0.8 | | | | | 3.1 | | | | | 2.1 |
| | 0-15 | | | | 22.5 | 22.4 | | | | 2.0 | 1.4 | | | | 8.7 | 6.1 | | | | 6.3 | 3.6 |
| | 15-30 | | | | 19.1 | 22.9 | | | | 2.0 | 2.2 | | | | 10.4 | 9.8 | | | | 7.7 | 6.2 |
| | 0-30 | | | | | | | | | | | | | | | | | | | | |
| | 30-60 | | | | | 15.1 | | | | | 1.4 | | | | | 9.5 | | | | | 4.5 |
| | 60-90 | | | | | 14.7 | | | | | 1.0 | | | | | 6.7 | | | | | 2.6 |
| 90-120 | | | | | 18.2 | | | | | 1.0 | | | | | 5.5 | | | | | 2.0 | |

Table 14 (continued).

| Treat ment | Depth cm | Exchangeable Mg (me/100g) | | | | | Exchangeable Ca (me/100)g | | | | | pH (paste) | | | | | EC Sat. Extr. (uS/cm) | | | | | | | |
|---------------|-------------|---------------------------|------|---|------|-------|---------------------------|------|------|------|------|------------|-----|-----|-----|-----|-----------------------|------|------|------|---|------|------|------|
| | | 1* | 2 | 3 | 4 | 5 | 1 | 2 | 3 | 4 | 5 | 1 | 2 | 3 | 4 | 5 | 1 | 2 | 3 | 4 | 5 | | | |
| 20 | 0-3 | | | | | 6.5 | | | | | 17.4 | | | | | 7.1 | | | | | | | | 579 |
| | 0-15 | | | | 5.1 | 5.5 | | | | | 13.6 | | | | | 6.4 | 7.3 | | | | | | 1724 | 788 |
| | 15-30 | | | | 5.4 | 4.3 | | | | | 15.0 | | | | | 6.3 | 7.4 | | | | | 2092 | 876 | |
| | 0-30 | 5.3 | 6.8 | | | | 20.8 | 39.5 | | | | 7.0 | 7.5 | 7.2 | | | | 960 | 2148 | 3158 | | | | |
| | 30-60 | 6.5 | 8.9 | | | 5.3 | 39.7 | 45.0 | | | 45.4 | 7.3 | 7.6 | 7.6 | | | 7.6 | 851 | 1453 | 3857 | | | | 1652 |
| | 60-90 | 12.0 | 8.8 | | | 8.9 | 52.6 | 40.4 | | | 45.9 | 7.9 | 7.7 | 7.8 | | | 7.8 | 2815 | 2746 | 2257 | | | | 2643 |
| 90-120 | 13.7 | 13.8 | | | 11.7 | 47.7 | 39.9 | | | 44.3 | 7.7 | 8.0 | 8.0 | | | 7.7 | 2416 | 3783 | 1169 | | | | 4956 | |
| 35 | 0-3 | | | | | 6.8 | | | | 16.9 | | | | | | 7.6 | | | | | | | | 903 |
| | 0-15 | | | | 4.7 | 5.2 | | | | 14.2 | 15.2 | | | | | 6.7 | 7.2 | | | | | | 1572 | 1399 |
| | 15-30 | | | | 4.5 | 4.7 | | | | 15.5 | 21.9 | | | | | 6.7 | 7.4 | | | | | 1331 | 1407 | |
| | 0-30 | 3.9 | 5.4 | | | | 17.3 | 28.6 | | | | 6.9 | 7.2 | 7.4 | | | | 1592 | 1694 | 2665 | | | | |
| | 30-60 | 4.7 | 8.1 | | | 5.2 | 34.7 | 51.6 | | | 46.3 | 7.5 | 7.6 | 7.5 | | | 7.9 | 1066 | 2429 | 3393 | | | | 1471 |
| | 60-90 | 5.7 | 10.8 | | | 8.6 | 44.1 | 54.8 | | | 46.9 | 7.9 | 7.6 | 7.7 | | | 7.9 | 788 | 3584 | 2798 | | | | 1927 |
| 90-120 | 8.2 | 12.3 | | | 13.2 | 38.5 | 48.4 | | | 45.0 | 7.9 | 7.6 | 7.6 | | | 7.8 | 706 | 5187 | 5086 | | | | 2836 | |
| 35G | 0-3 | | | | | 5.2 | | | | 21.1 | | | | | | 7.5 | | | | | | | | 1343 |
| | 0-15 | | | | 4.3 | 5.9 | | | | 16.2 | 18.5 | | | | | 6.7 | 7.2 | | | | | | 2753 | 1700 |
| | 15-30 | | | | 4.3 | 5.5 | | | | 16.2 | 21.9 | | | | | 6.3 | 7.2 | | | | | 2158 | 1805 | |
| | 0-30 | 4.7 | | | | | 24.0 | | | | | 7.0 | | 7.1 | | | | 1233 | | 3900 | | | | |
| | 30-60 | 6.2 | | | | 6.0 | 50.0 | | | 22.9 | 7.3 | | | 7.4 | | | 7.7 | 655 | | 3582 | | | | 1654 |
| | 60-90 | 7.6 | 7.8 | | | 8.8 | 49.9 | 22.4 | | 46.4 | 7.9 | 7.6 | | 7.6 | | | 7.7 | 2001 | 1684 | 2903 | | | | 2303 |
| 90-120 | 13.6 | | | | 9.7 | 127.3 | | | 46.6 | 7.9 | | | 7.8 | | | 7.7 | 8332 | | 4476 | | | | 3505 | |
| 50 | 0-3 | | | | | 5.9 | | | | 15.4 | | | | | | 7.3 | | | | | | | | 2402 |
| | 0-15 | | | | 5.3 | 4.3 | | | | 14.6 | 14.2 | | | | | 6.8 | 7.2 | | | | | | 1808 | 1836 |
| | 15-30 | | | | 5.1 | 3.5 | | | | 15.3 | 14.6 | | | | | 6.7 | 7.4 | | | | | 1746 | 1624 | |
| | 0-30 | 3.8 | 4.3 | | | | 16.2 | 16.8 | | | | 7.0 | 6.9 | 7.2 | | | | 1314 | 1880 | 1925 | | | | |
| | 30-60 | 4.0 | 4.1 | | | 3.1 | 27.7 | 34.4 | | 34.1 | 7.8 | 7.5 | 7.5 | | | 7.7 | 869 | 1404 | 2298 | | | | | 1731 |
| | 60-90 | 4.9 | 5.1 | | | 3.8 | 40.8 | 40.7 | | 43.5 | 8.1 | 7.7 | 7.9 | | | 8.0 | 859 | 1341 | 2277 | | | | | 1569 |
| 90-120 | 9.5 | 11.0 | | | 7.9 | 38.0 | 40.4 | | 44.7 | 8.1 | 7.8 | 7.7 | | | 7.9 | 850 | 1180 | 2367 | | | | | 1669 | |
| 20G | 0-3 | | | | | 4.5 | | | | 22.0 | | | | | | 7.2 | | | | | | | | 1840 |
| | 0-15 | | | | 5.5 | 3.7 | | | | 15.9 | 15.4 | | | | | 7.0 | 7.0 | | | | | | 1449 | 1476 |
| | 15-30 | | | | 4.0 | 4.8 | | | | 16.2 | 16.1 | | | | | 6.3 | 7.0 | | | | | 1494 | 1569 | |
| | 0-30 | | | | | | | | | | | | | | | | | | | | | | | |
| | 30-60 | | | | | 5.8 | | | | 42.5 | | | | | | 7.3 | | | | | | | | 2258 |
| | 60-90 | | | | | 9.5 | | | | 44.4 | | | | | | 7.7 | | | | | | | | 2645 |
| 90-120 | | | | | 14.5 | | | | 41.1 | | | | | | 7.8 | | | | | | | | 4323 | |

*Sampling dates: 1=Spr'80, 2=Fall'80, 3=Fall'81, 4=Spr'82, 5=Fall'82

data available to justify the dispersion damage is an ESP level between 6.7 and 11.1%.

A possible reasoning for the potentially higher ESP assumption is: If a farmer is applying irrigation water to the soil during a season to supply the crop with its moisture demands, usually very little leaching, if any, is taking place over a 3 or 5 month period. In some cases, new irrigators may be wetting only the top 30-45 cm of soil with each irrigation. After an irrigation event, suppose the top was wet to field capacity and ET began to draw moisture back out to the surface. As the water volume decreases in the soil, the concentration of each ion increases. The first ions which tend to precipitate are the least soluble inorganic compounds such as CaCO_3 and MgCO_3 (high bicarbonates are reduced to carbonates as concentration increases) and the last ions to precipitate during drying are the Na, Cl, and SO_4 . During this process, the SAR of the soil solution increases with decreasing soil moisture volumes. Therefore, it is quite important to thoroughly wet the soil to greater depths to distribute salts more evenly and then try to keep the soil from completely drying out near the soil surface. If the soil surface does dry out and the soluble calcium is precipitated in the form of CaCO_3 , unless soil pH values are below 7.8 (Table 15), very little calcium will come back into solution upon rewetting. It's important to remember that at each irrigation additional amounts of Ca, Mg, and Na are moved into the soil solution and that the above potential exists throughout the irrigation season.

Table 15. Solubilities of CaCO_3 at various pH's. (Taken from the U.S.D.A. Handbook No. 60.) (Atmospheric pCO_2).

| <u>pH value of CaCO_3 saturated solution</u> | <u>Solubility of CaCO_3 (me/l)</u> |
|------------------------------------------------------------------|--------------------------------------------------------|
| 6.21 | 19.30 |
| 6.50 | 14.40 |
| 7.12 | 7.10 |
| 7.85 | 2.70 |
| 8.60 | 1.10 |
| 9.20 | 0.82 |
| 10.12 | 0.36 |

By looking at the ESP levels of the several treatments from Table 14, it appears that the plot with the least amount of water or sodium applied to it, had the highest levels of exchangeable sodium in the soil profile. In the first year of irrigation, penetration of the water on plots 50, 35, and 35G was sufficient to move some sodium deeper in the soil profile. The soil was very dry prior to initiation of the project, consequently, the soil readily accepted and moved water quickly deeper in the soil profile. Near the end of the second year, water movement downward became less and run-off increased on the 50 treatment. For these two circumstances, there are two different results in ESP values.

Each of the plots received the same frequency of irrigation but different amounts each time. At the end of the first and second year, plot 20 had more exchangeable sodium in the top 120 cm than the other treatments. In 1982, water table problems were evident on the 35G and 50 plots. This caused a restriction in downward water movement when irrigation and higher rainfall amounts came. Thus, plot 20 total soil exchangeable sodium dropped and the other treatments increased.

It was evident that the exchangeable sodium levels at the surface 30 cm dropped on all treatments from 1981-1982, probably due to the dilution of increased rainfall.

According to the ESP values, no differences were evident between the gypsum and non-gypsum plots either for two annual applications or a one-time heavy application. Keren and O'Connor in 1982 (18) concluded that for sodic soil reclamation (exchangeable sodium removal), by increasing the soil water velocity, the gypsum dissolution rate is decreased. Also, they said that the calcium concentration in solution is dependent on both the dissolution rate coefficient and the contact time between an elemental volume of water (soil water velocity) and a unit of surface area of gypsum fragments. Non-incorporated large fragments of gypsum, then, would not be as effective in sodium removal as well-incorporated powdered gypsum. They also found that the efficiency of replacing Na by Ca in soil of ESP = 20 was a function of soil water velocity and that realistic values for Na removal were between 52 and 81% for various soil water velocities. The water velocities they were working with were 13.5, 2.9, and 1.16 cm/hr.

This reclamation study would certainly indicate that trying to remove exchangeable sodium with high annual rates of wastewater would be quite inefficient for gypsum utilization in addition to adding heavy amounts of magnesium sulfate to the ground waters (refer to observation well water quality, Appendix G). The obvious answer to this type of problem would be to mix the gypsum into the irrigation water prior to application and prevent sodium attachment. Ground waters would still

be receiving magnesium sulfates but because gypsum utilization efficiencies would be higher, the amount necessary to add would be less to accomplish the same effects.

One significant point that should be mentioned is the difference in SAR of the soil solution between the 20 and 20G plot for the 0-15 cm depth (Table 14). The $\text{Ca}^{++}/\text{Na}^{+}$ ratio for that depth on the 20G plot is 3.7 times higher than for the same treatment without gypsum (plot 20) in September 1982. The SAR's for that same depth in the spring 1982 (before gypsum) were 6.1 for the 20 and 6.3 for the 20G plot. This indicates that a non-equilibrium condition exists. When the $\text{ESP} > \text{SAR}$, there is a gradient and a tendency for the ESP to drop and for the SAR to increase. Consequently, in time, one would expect the exchangeable sodium to be reduced. This condition is caused by the increased concentration of Ca^{++} due to the dissolution of the gypsum.

Saturated Hydraulic Conductivity

Usually, the soil ESP and electrolyte concentration are used as a measure to indicate soil permeability. The relationship between these two parameters and saturated hydraulic conductivity ($K\theta_g$) on South Dakota soils is currently being studied.

The basic concern in using this type of wastewater for irrigation is to maintain soil permeability and infiltration capacity for perhaps 20-25 years. This is an absolute necessity for wastewater acceptance and subsequent treatment. Consequently, it became necessary to try to evaluate the permeability differences between the soils in each treatment and the check.

First of all, sprinkler or double-ring infiltrometers were suggested

to obtain the results desired. However, a water table was present within .67 meters (2.2 ft) of the surface on the 50 plot and 1.2 meters (4 ft) on the 35G plot. Because of this, it was felt that the saturated conditions would quickly slow down the infiltration curve on those plots and a comparison of that data to the data on the other plots would be difficult. In addition to this, a check on the permeability of the soil surface was desired without the presence of a restricting boundary beneath. Therefore, it was decided to use small undisturbed surface cores to test in the laboratory under similar environments.

A shortage of brass sleeves and time prevented the collection of 12 replications from every treatment; however, a sufficient number of samples was obtained for comparison purposes. The $K(\theta_s)$ data on all the cores is presented in Table 16. (Refer to Figures 10 and 11 for the equipment used to obtain the values.) Deionized water was used to pump through the cores from the bottom to the top to reduce air entrapment in the cores. Mercuric chloride was put in the water to inhibit bacterial growth during the test.

The variability within a treatment among observations was very high. In fact in almost every case, the standard deviation exceeded the mean. The analysis of variance, presented in Table 17, basically says that there is no difference between treatment means at the .05 level of significance. However, there is an algebraic difference in the means with the check the fastest and 20G the slowest. Dunnett's test (Table 18) was used to compare the check mean against the treatment mean for $K(\theta_s)$; however, no significant difference at

Table 16. Replications of saturated hydraulic conductivity measurements for the top 3 cm for the various treatments. Values are averages for the first six hours (units are cm/hr).

| | Treatment | | | | | |
|-----------|-----------|--------|--------|--------|-------|-------|
| | Check | 50 | 35G | 35 | 20 | 20G |
| | 0.0254 | 0.5801 | 0.0758 | 0.2043 | .5070 | .1608 |
| | 0.1858 | 0.2865 | 0.0198 | 0.0118 | .0078 | .0031 |
| | 0.1461 | 0.0001 | 0.1602 | --- | .0336 | .0113 |
| | 0.2371 | 0.1905 | 0.1504 | 0.0079 | .0239 | .0285 |
| | 0.2272 | 0.0069 | 0.3761 | 0.0129 | --- | .0134 |
| | 1.0517 | 0.0547 | 0.3309 | 0.0708 | --- | .0015 |
| | 0.0239 | 0.0108 | 0.3503 | 0.0490 | --- | --- |
| | 0.2452 | 0.0671 | 0.1570 | 0.0935 | --- | --- |
| | 0.0983 | 0.0218 | 0.0043 | 0.2387 | --- | --- |
| | 0.1374 | 0.0172 | 0.1844 | 0.0023 | --- | --- |
| | 0.2905 | 0.6363 | 0.1738 | 0.0113 | --- | --- |
| | 0.6427 | 0.0905 | 0.0226 | 0.0212 | --- | --- |
| Total | 3.3110 | 1.9625 | 2.0056 | 0.7237 | .5723 | .2186 |
| Mean | 0.2759 | 0.1635 | 0.1671 | 0.0658 | .1431 | .0364 |
| S.D. | 0.2929 | 0.2247 | 0.1287 | 0.0826 | .2428 | .0617 |
| N | 12 | 12 | 12 | 11 | 4 | 6 |
| Std error | 0.0564 | 0.0564 | 0.0564 | 0.0589 | .0976 | .0797 |

Table 17. Analysis of variance for laboratory saturated hydraulic conductivity measurements of the surface 3 cm at the completion of the project.

| | <u>DF</u> | <u>SS</u> | <u>MS</u> | <u>F*</u> |
|------------|-----------|-----------|-----------|-----------|
| Total | 56 | 2.2958 | .0410 | |
| Treatments | 5 | 0.3506 | .0701 | 1.84 |
| Error | 51 | 1.9452 | .0381 | |

*Critical value for $F_{.05}(5,51) > 2.40$.

Table 18. Dunnett's test of the check mean vs. treatment means for saturated hydraulic conductivities of the top 3 cm of soil.

| | |
|--------------|------|
| Check vs 50 | 1.41 |
| Check vs 35G | 1.36 |
| Check vs 35 | 2.52 |
| Check vs 20 | 0.96 |
| Check vs 20G | 2.12 |

*Critical value for $\alpha = .05$ is $d_{.025}(5,51) = 2.60$.

the .05 level was determined. There appeared to be too much variability within each treatment for differences in $K(\theta_s)$ to be significant.

Some of the differences may be significant, however, because of two important factors. First, in determining the $K(\theta_s)$ values, pressure heads between treatments were not constant. Table 19 shows the variation in head between treatments and between groups of tests.

Table 19. Variation in pressure heads (cm) used to calculate $K(\theta_s)$ according to Darcy's law.

| | Treatments | | | | | |
|---------|--------------|-----------|------------|-----------|-----------|------------|
| | <u>Check</u> | <u>50</u> | <u>35G</u> | <u>35</u> | <u>20</u> | <u>20G</u> |
| 1st set | 20-25 | 45-60 | 104-122 | 45-50 | 25-35 | 200-1000* |
| 2nd set | 20-25 | 40-45 | 37-40 | 30-35 | | |

*One core on the channel of six dropped drastically in volume during the 6 hour test causing the marked increase in pressure.

They vary from 20-25 cm for the check plot to 200-1000 cm for the 20G plot. Darcy's law, when pressure heads change, does not hold to be linear using these cores with this type of apparatus. There are other factors which cause hysteresis in the theory. Figure 17 shows two treatments with 6 replications each and the subsequent $K(\theta_s)$ values every 15 minutes for 6 hours. All six cores were on one channel with the pump delivering a constant flow rate. When one or two channels were clamped off because of blow-outs or severe channeling, the pressure head went up on the remaining cores. All precautions were taken to insure similar pressures to all cores throughout the test, however, channeling or blow-out's could not be predicted.

Second, the 20 and 20G plot showed severe dispersion when water was delivered to the cores. The first few drops of effluent were totally

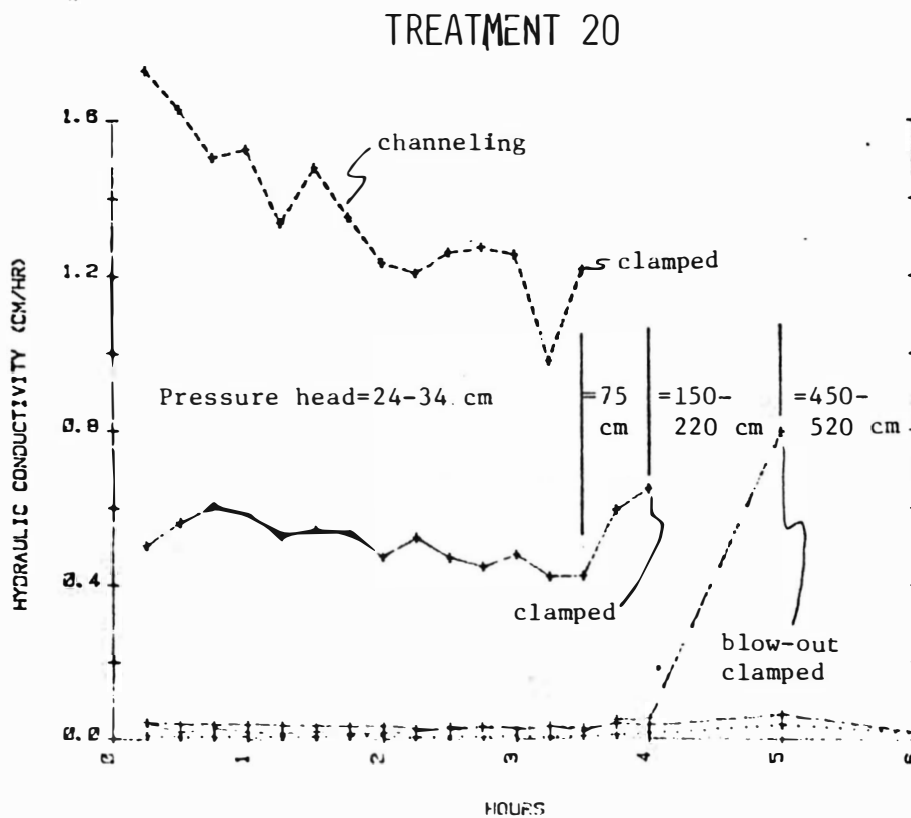
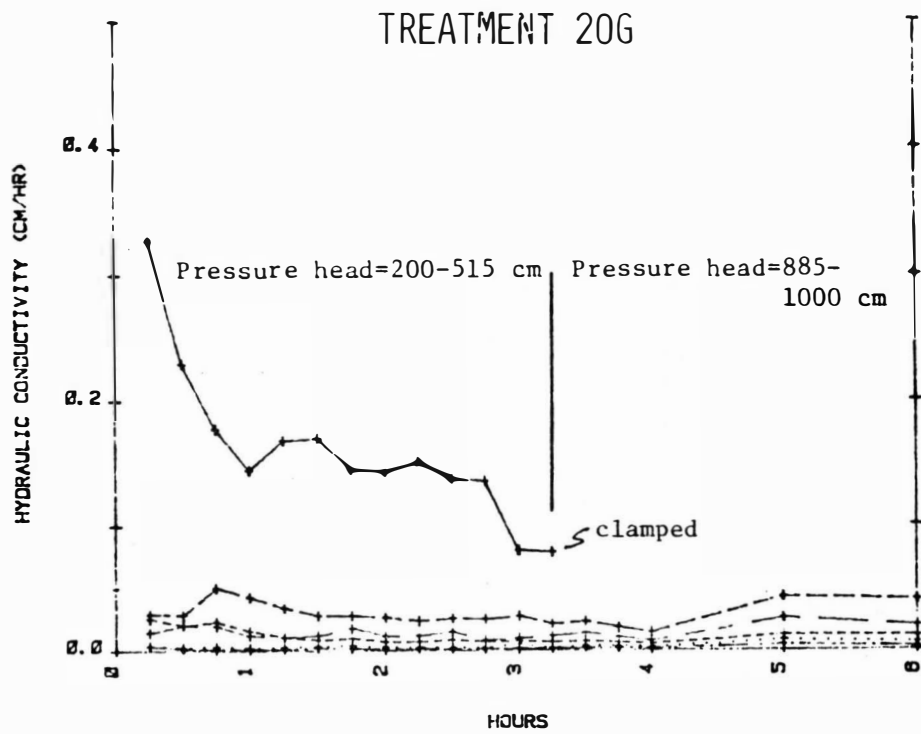

Figure 17. Graphical depiction of the change of $K(\theta_s)$ with increasing pressure heads on two treatments.

black indicating that the particles were dispersed prior to wetting by the water. This occurred on every core tested in the 20 and 20G plots, but no more than slight amber discoloration of the effluent was evident on the other treatment cores tested. Table 19 shows the amount of dispersed residue which was lost from each core during the test as the pore volumes increased. In all replications, dispersed residue decreased with increasing pore volumes. Table 14 gives the soil chemical analysis for the 0-3 cm depth for each treatment.

Two theories are offered to explain the difference in dispersion between treatments. First, perhaps only the 20 plot had ESP's high enough to cause the release of dispersed soil particles (they had ESP's which approached 16 at the 0-30 cm depth).

Second, the dispersed soil particles, if any were present, on the other treatments may have been washed below the 3 cm level, whereas the 20 plot, with its lower leaching and applications of wastewater, may have dispersed soil particles still remaining in the top 3 cm. If the first theory is true, clay particles must have become dispersed during the 1981 season when little rainfall came and ESP's were 16 or higher. The $K(\theta_s)$ tests on that soil after one year indicate dispersed soil particles with ESP's ranging from 3-4.8 on the test cores. This may mean that if a "critical period" (ESP levels equal soil dispersion) occurs in the field perhaps in a dry, hot spell, dispersed surface soil particles may stay dispersed for long periods of time even though the subsequent ESP levels would indicate that there is no danger of soil dispersion. This theory should be investigated further to determine if this kind of thing occurs often. If it does, many irrigators may

Table 19. Dispersed residue lost through a 35 micron plastic filter during a six hour hydraulic conductivity test in a 3 cm x 5.4 cm ID tempe cell using distilled water for various treatments and pore volumes, 1982.

| <u>Treatment</u> | <u>Rep.</u> | <u>effluent collected(ml)</u> | <u>Total residue(g)</u> | <u>Specific pore volume(ml)</u> | <u># of pore vol collected</u> | <u>Dispersed residue (g/cm²/pore volume)</u> | |
|--------------------|-------------|-------------------------------|-------------------------|---------------------------------|--------------------------------|---------------------------------------------------------|------|
| 20G" (ESP=3.22) | 1 | 500 | .2123 | 29 | 17.2 | .159 | |
| | | 500 | .0418 | " | 17.2 | .031 | |
| | | 160 | .0226 | " | 5.5 | .005 | |
| | 2 | 93 | .0783 | " | 3.2 | .011 | |
| | | 3 | 160 | .4848 | " | 5.5 | .116 |
| | | 4 | 436 | .1435 | " | 16.7 | .105 |
| 5 | 256 | .1696 | " | 8.8 | .065 | | |
| | 6 | 41 | .0435 | " | 1.4 | .003 | |
| 20" (ESP=4.55) | 1 | 500 | .1729 | 34 | 14.7 | .111 | |
| | | 101 | .0092 | " | 3.0 | .001 | |
| | 2 | 49 | .1209 | " | 1.4 | .007 | |
| | | 3 | 500 | .0926 | " | 14.7 | .059 |
| | | 500 | .0382 | " | 14.7 | .025 | |
| | 4 | 89 | .0027 | " | 2.6 | .0003 | |
| | | 82 | .1428 | " | 2.8 | .017 | |
| | | 5 | 371 | .2240 | " | 10.9 | .107 |

eventually have serious permeability problems which may not be easily reversed.

Drainage Water Quality

From suction tensiometers

Suction tensiometers were installed at depths of 30, 45, 60, 90, 120, and 150 cm on each plot for the purpose of monitoring soil water before it would move below the tip of the root zone. In 1981 a second set of tensiometers was installed on plot 50 and was, subsequently, called 50A. A lot of the concern in wastewater treatment by the soil is that the groundwaters might become contaminated. This second set of tensiometers was installed to obtain data from a second replication on the high annual application plot to better identify any potential contamination problems.

The parameters which were analyzed were EC, HCO_3 , Cl, Na, NH_3 , total PO_4 , pH, and NO_3 . The data which was collected and analyzed is given in Appendix A (1980), B (1981), and C (1982). A few color graphs have been made and will be presented under the appropriate parameter which is discussed.

From observation wells

Observation wells were installed at the center of each plot to monitor groundwater quality and water table changes. The parameters which were analyzed were similar to the suction tensiometers. Spot checks of Ca, Mg, K, and SO_4 were added to the list to obtain information which might be pertinent relative to the concentration of the same parameters of the applied water.

Figures 18, 19, 20, and 21 are graphical representations of the changes in EC, Na, Cl, and NO_3 of the observation wells with time by year by treatment. Tables of the data from the observation wells are presented in Appendix G. These figures will be referred to occasionally in discussion of that particular parameter in the drainage water.

Nitrogen as nitrates

Nitrate groundwater contamination tends to be a major concern in wastewater disposal on soils because the ion is so readily leachable. First of all, nitrate levels in the effluent were not found to be very high except during late June and July when total organic nitrogen and ammonia were converted to nitrates. The levels at this time were not in excess of 15 ppm, however. This appeared to be the same time when higher levels were evident in the soil. The maximum level of nitrate concentration in the soil on any plot was 150 ppm. This was at the 45 cm depth on plot 50, 1981 (Figure 22). These levels were concurrent with the higher levels in the wastewater. At no time did the nitrate level in the samples taken exceed 10 ppm below 120 cm on any plot.

Nitrate levels from the observation wells were below 1 ppm for the 50 and 20 plots (Figures 18 and 21) for the entire project. Nitrate levels in plot 35 and 35G were higher (2-10 ppm) (refer to Figures 19 and 20). Some of the explanation for these differences can be seen in Figure 2, the boring logs of the various plots. Plot 50 had a layer of heavy clay loam below the 2 meter depth, whereas plot 35 had a layer of pure sand below 1 meter with sand and clay loam intermixed below

OBSERVATION WELL WATER QUALITY

— 1980 1981 --- 1982 PLOT 50

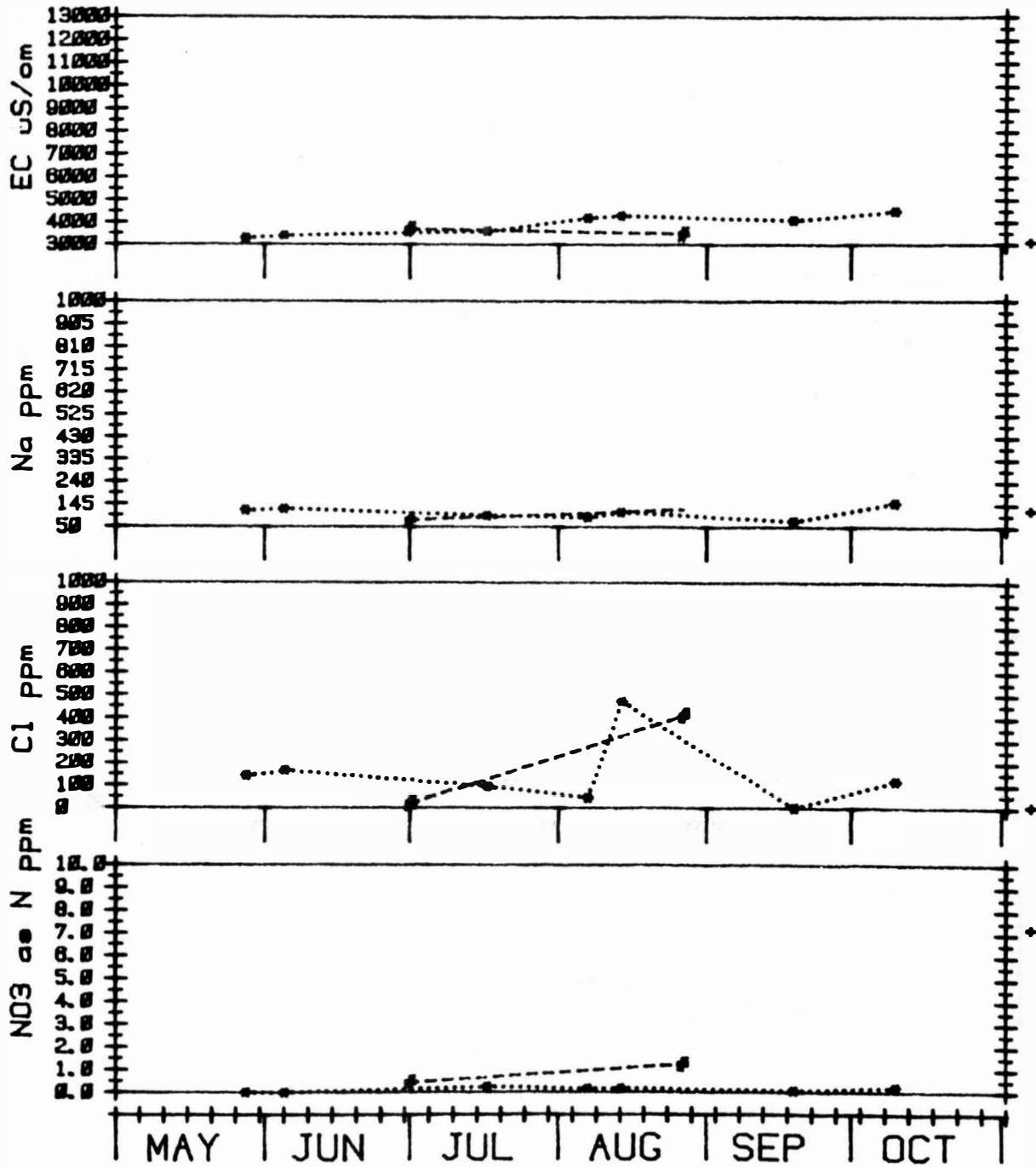

Figure 18. Changes in observation well water quality with time for plot 50.

OBSERVATION WELL WATER QUALITY

— 1980 1981 --- 1982 PLOT 35G

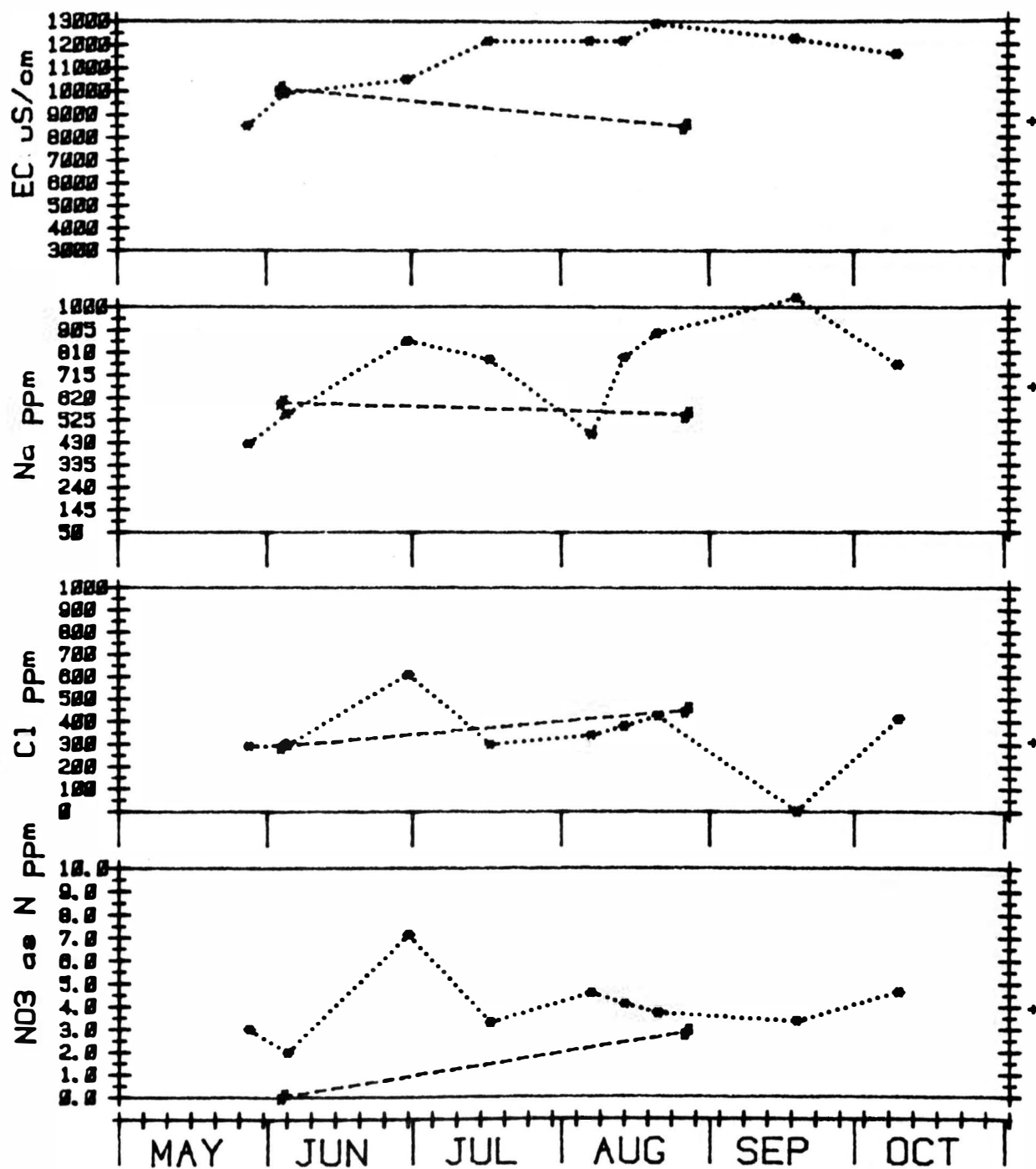

Figure 19. Changes in observation well water quality with time for plot 35G.

OBSERVATION WELL WATER QUALITY

— 1980 1981 --- 1982 PLOT 35

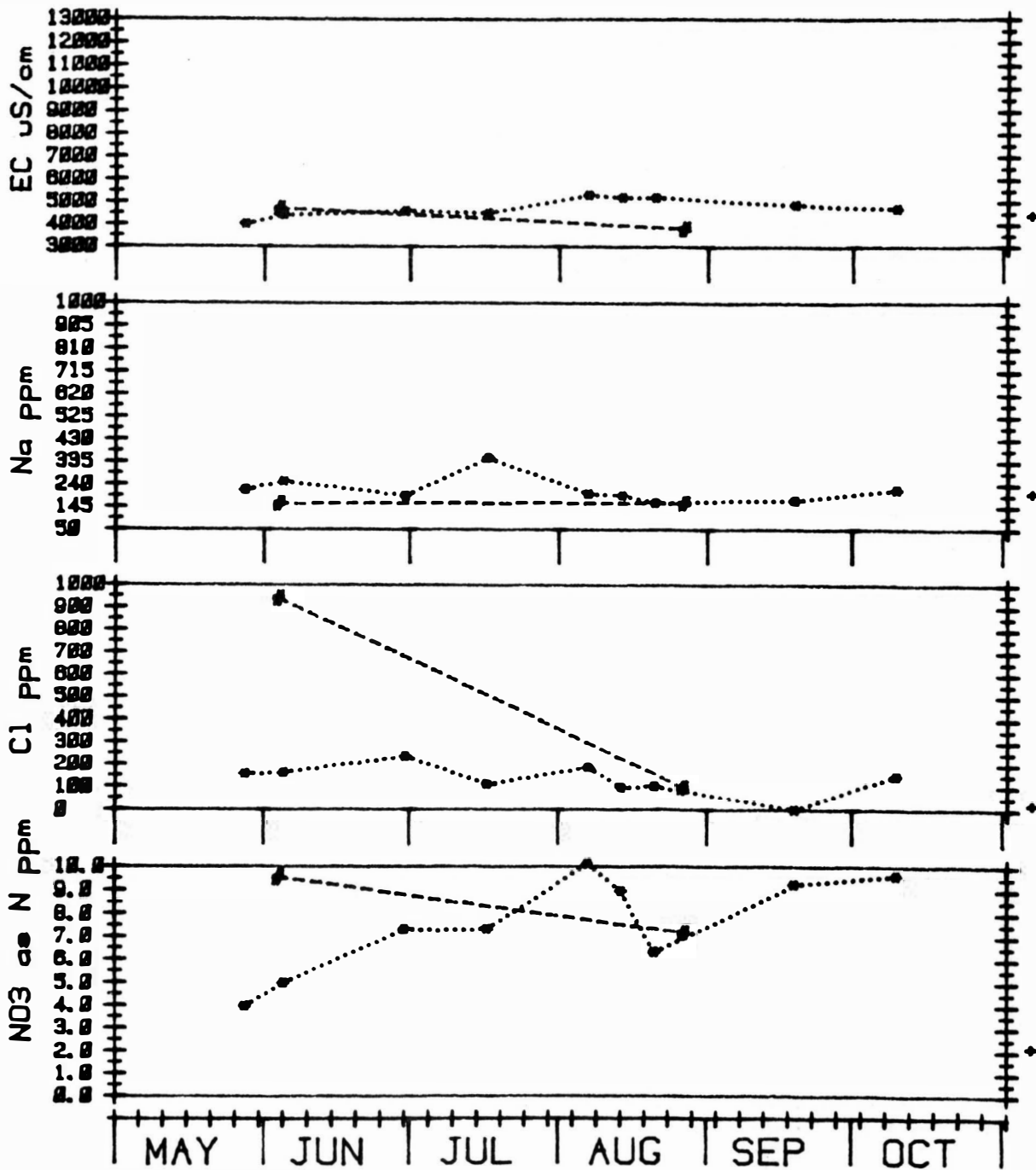

Figure 20. Changes in observation well water quality with time for plot 35.

OBSERVATION WELL WATER QUALITY

— 1980 1991 --- 1992 PLOT 20

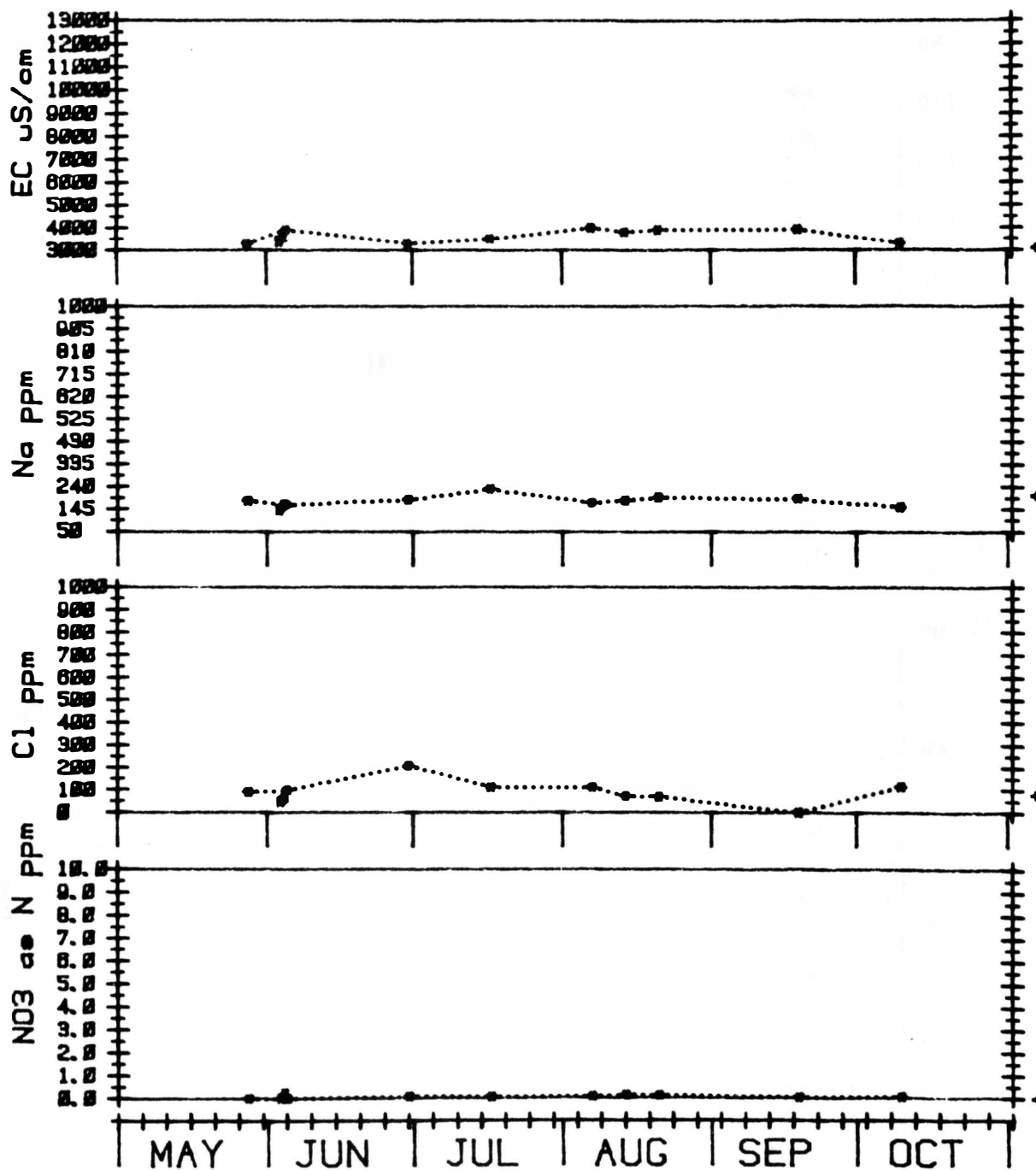

Figure 21. Changes in observation well water quality with time for plot 20.

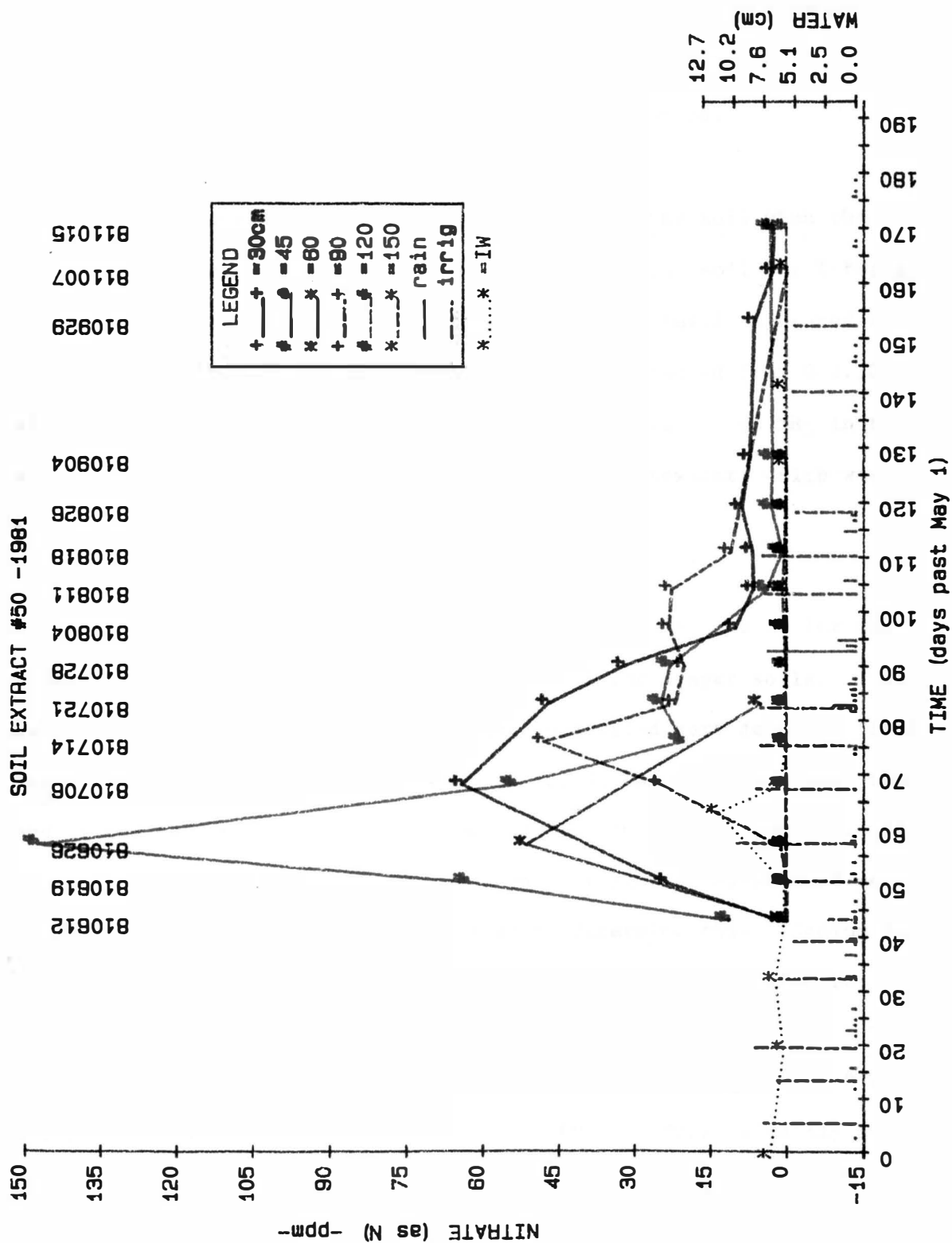

Figure 22. Nitrate levels at various times and depths in the soil solution from plot 50, 1981.

that layer. Since these holes were cased and packed with sand around the casing close to the surface, it is conceivable that horizontal water movement in the sand layer (plot 35) may have occurred.

Total phosphates and ammonia

Total phosphates and ammonia were higher in the soil when the levels in the wastewater were higher. Levels in the soil for T-PO₄ did not exceed 1 ppm below the 120 cm depth. Ammonia levels appeared to increase with depth in the soil. Levels usually ranged from 0-2.50 ppm at the 120 and 150 cm depths. Again, the higher levels of NH₃ in the soil correlated with the higher levels in the wastewater, which was mainly in the spring and early summer.

EC

At the beginning of the project, for most plots, the EC for the upper 60 cm usually was higher than the EC of the deeper soils. This was because the water and salts had not penetrated very deep the first season. The exception to this was plot 20; it had EC values near the end of the season at the 150 cm depth of 7500-10,000 μ Siemens/cm. EC values may have continued to increase on that plot in subsequent years; however, extracts could not be obtained to determine this. Sodium and chlorides were the main contributors to these high EC's (refer to Appendix A--1980 field soil extracts).

As the years of irrigation increased, the EC values below 60 cm for all plots became higher than the EC above 60 cm. This is mainly due to movement of concentrated salt solutions below the area of highest plant root densities. Figure 23 shows the effect that a heavy (7.5 cm) rain-fall can have on the soil profile in regard to EC. On August 1, 1981

Figure 23. Effect of a heavy rainfall on the salinity in the soil profile for plot 50, 1981.

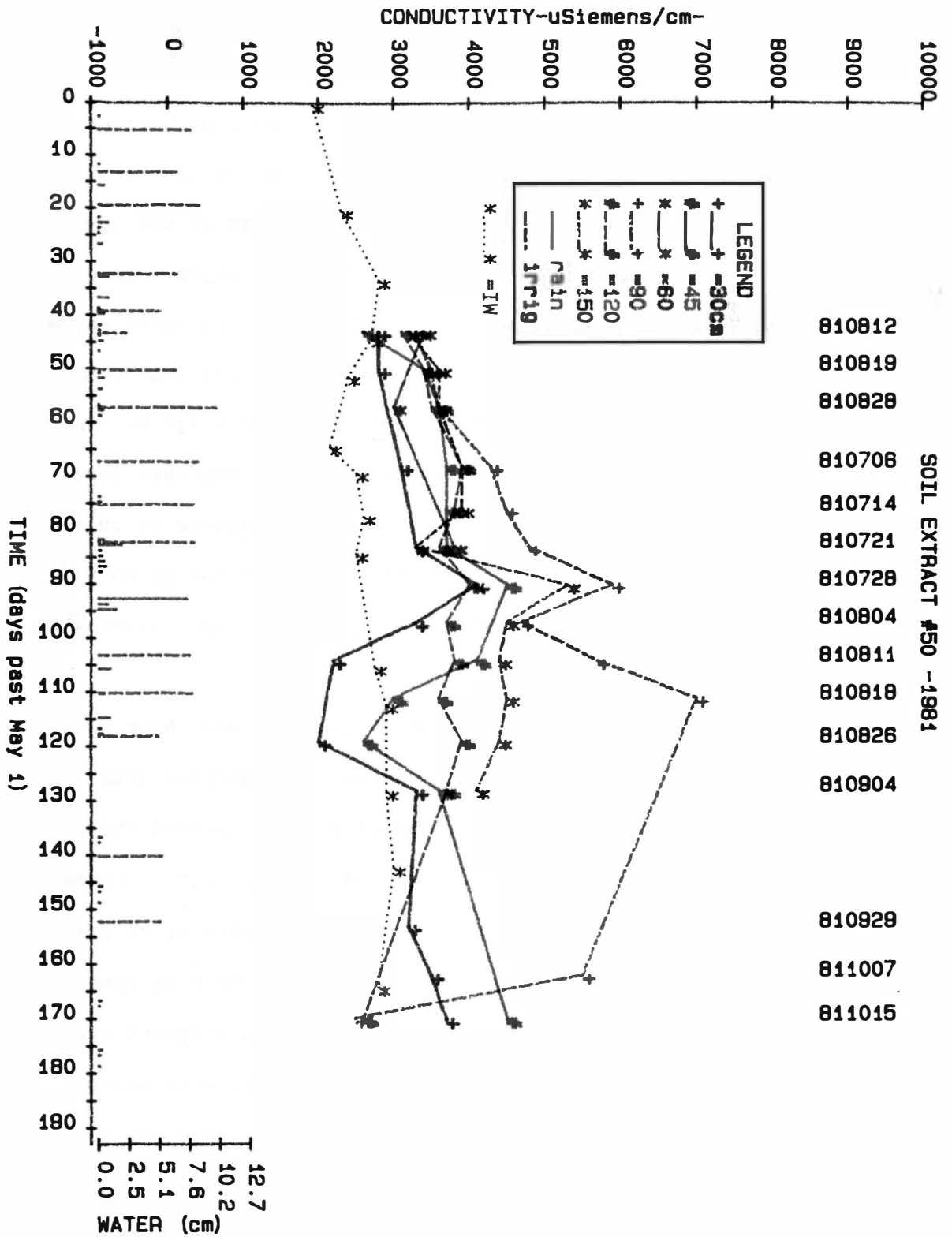

the only significant rainfall came between two soil extract sampling dates. The salinity at all depths was reduced even though the soil was saturated below 90 cm. The sodium and chloride values show the same type of pattern indicating that they were major constituents which contributed to the lower EC value. This "decrease" in salinity was due mainly to dilution rather than leaching. Notice in Figure 22 that the nitrate concentration from the 30 and 45 cm depth dropped after that rain, also. Figure 24 shows the EC of the 35G plot in 1981. Apparently the gypsum must have exchanged with Mg and Na to cause higher electrolyte concentrations (8000) in the lower depths. The pattern very closely resembles the chloride concentration for that same plot and year.

The EC in the observation wells varied from 3000-5000 μ Siemens/cm over the experiment for 20, 50 and 35 plots. However, the EC on plot 35G ranged from 8800-13,000 μ S/cm. The spot check analysis of this water quality showed magnesium and sulfates to be the dominant ions. Magnesium levels were four times higher than the other wells and sulfates were 4-8 times higher than the other wells. Sodium levels were also higher--in the range of 2 to 5 times higher than the other wells. Calcium levels were normal to the levels in the other wells (400-550 ppm). It's interesting to note that the peak of sodium levels in the 35G well came just three days after the application of gypsum for that year. But, only two light rainfalls occurred in the interim time period, hardly sufficient time for the groundwater to be affected by that event. Apparently the calcium in the gypsum is exchanging with magnesium and sodium on the soil exchange complex. It must be occurring

Figure 24. EC values in the soil with time and depth on plot 35G, 1981.

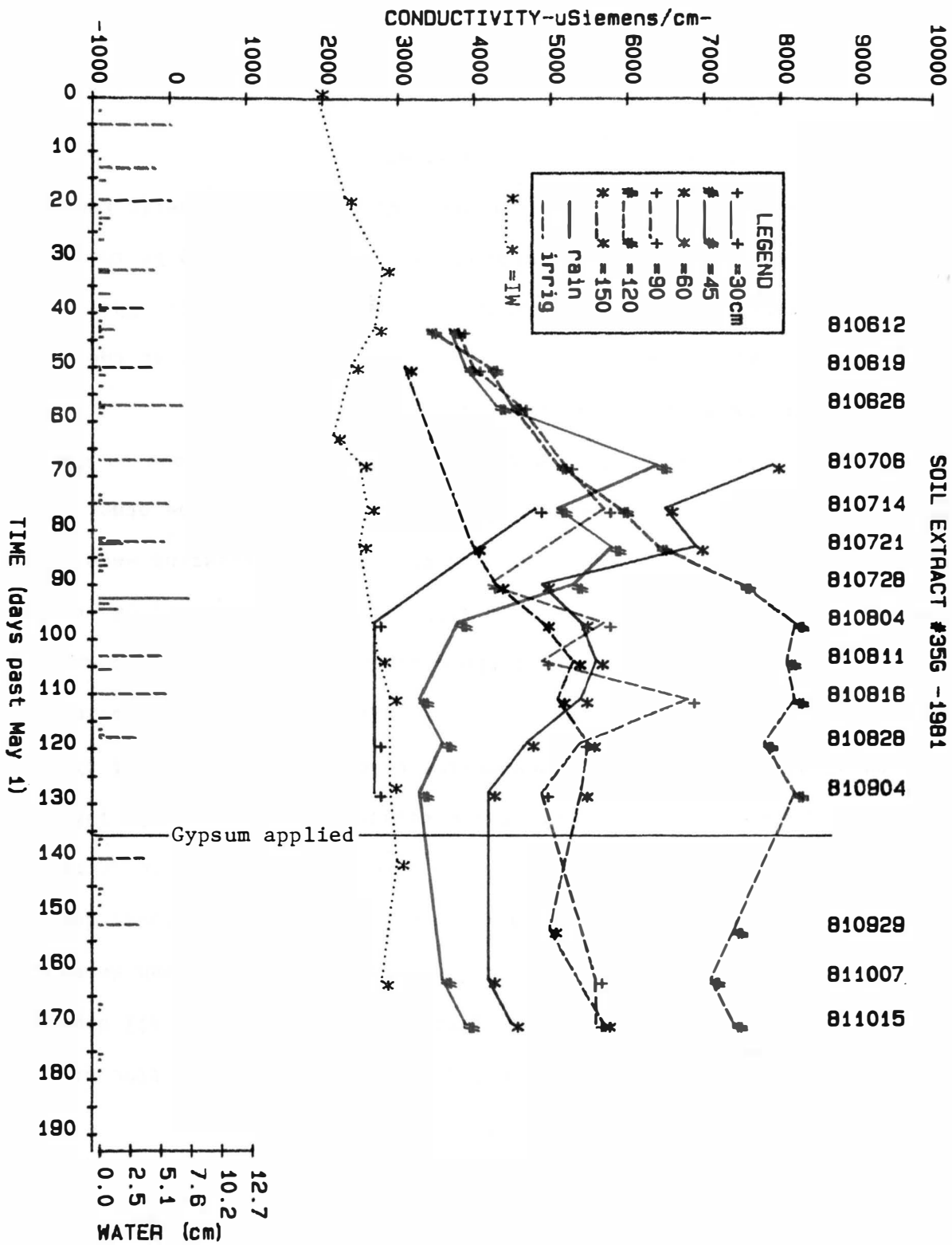

below 1.2 meters, however, because ESP values from soil samples don't seem to reflect the change above that level.

pH and bicarbonates

Figures 25 and 26 show the pH changes in the soil with time and depth for the 50 plot for 1981 and 1982. In 1980 the pH at all depths was in a range of 7.8-8.3 with little difference in pH between depths. In 1981 the pH of the upper 60 cm was much higher than the lower depths. As the season progressed, the pH of the lower depths tended to increase while the pH in the upper 60 cm stayed relatively constant. In 1982 the pH at all depths was very responsive to changes in the pH of the applied irrigation water. The pH at the beginning of the irrigation season, however, had dropped from the previous fall, as would be expected. After irrigation continued with the higher pH water, pH values in the soil tended to equilibrate with that of the irrigation water. Many times those values were over 8.4. This occurred on the other plots also. The high pH of the irrigation water is hazardous to the structure of the soil for two reasons.

First, beginning at a pH of ~8.2, bicarbonates (HCO_3^-) in the irrigation water, begin to be converted to carbonates ($\text{CO}_3^{=}$). The driving force which causes the high pH is the uptake of CO_2 by the algae in the wastewater. The algae need CO_2 for photosynthetic activity and the resultant reactions in the water are

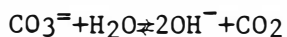
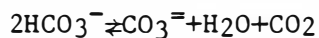

Consequently, as the algae growth increases, the demand for CO_2 increases and the equilibrium alkalinity situation shifts from bicarbonates

Figure 25. Changes in pH in the soil with depth and time for plot 50, 1981.

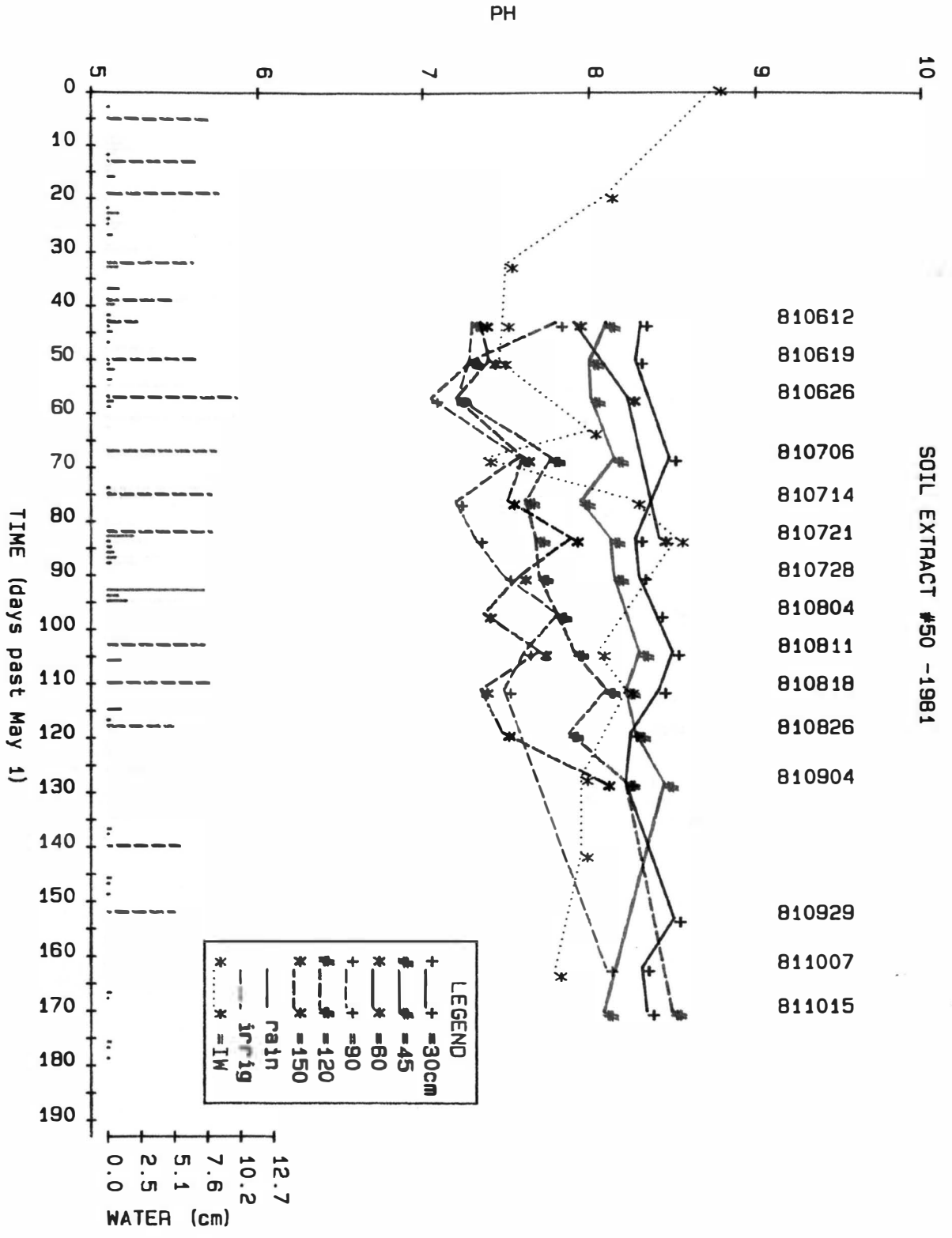

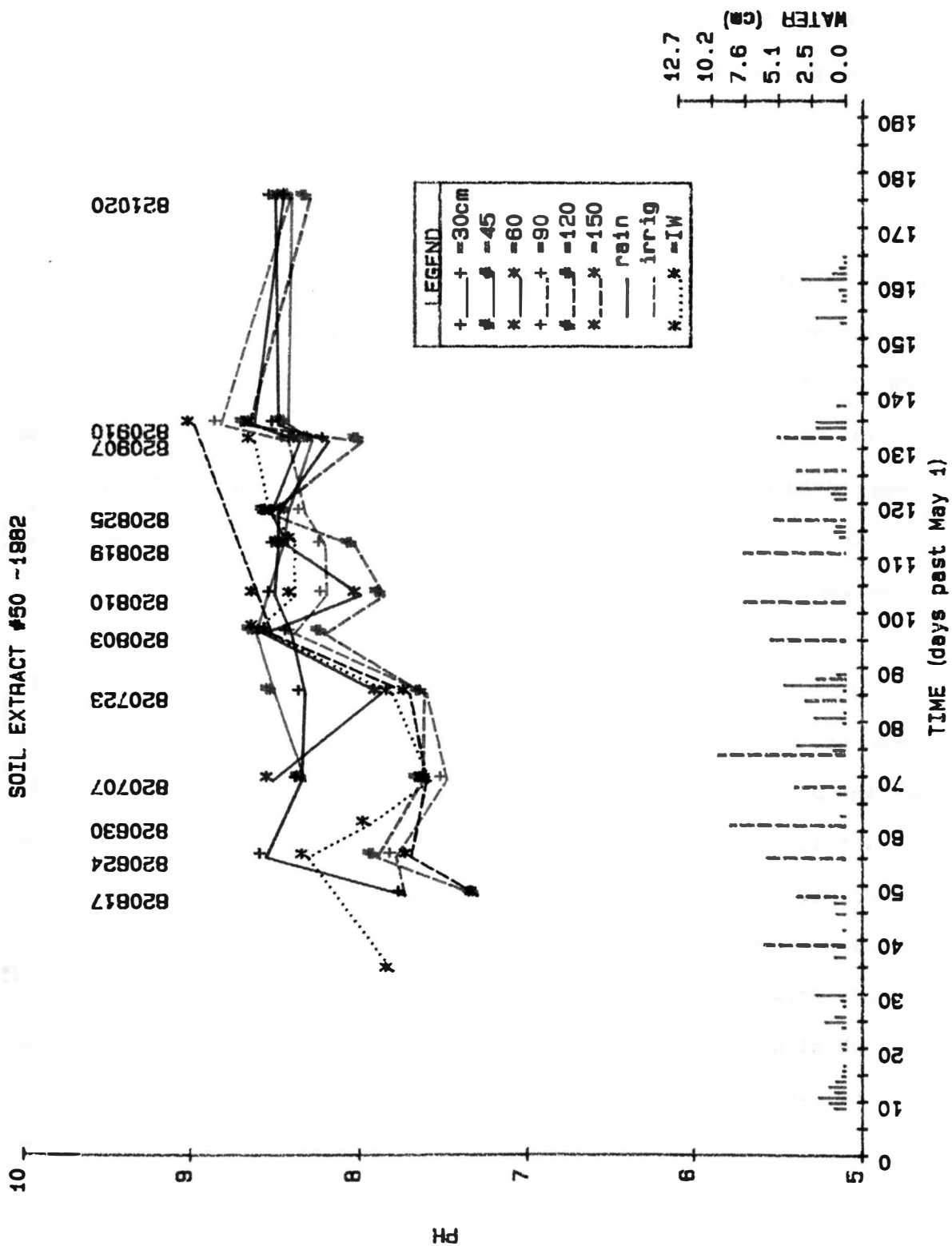
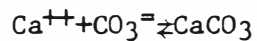

Figure 26. Changes in pH in the soil with depth and time for plot 50, 1982.

to carbonates to hydroxide, thus causing an increase in pH. When the carbonate ion concentration increases, if calcium ions are present, the solubility product of CaCO_3 may be exceeded to the point of causing precipitation by the following equation,



This reaction can readily take place between pH levels of 8.3 to 10. Because of this phenomenon, SAR_{iw} is consequently increased because of the removal of the divalent cation. As mentioned earlier, higher SAR waters tend to cause poor structure to the soils on which they are applied. There are some surface waters in the state which have algae blooms such as the above and have higher pH values because of this. The Shadehill Reservoir in northwestern South Dakota is one example.

The second reason the high pH waters are hazardous is due to the suppression of the release of natural Ca^{++} from the soil in the form of CaCO_3 . Table 15 showed that the solubility of CaCO_3 was quite low at pH values above 8.0. When high rates of wastewater are applied after a few years the soil tends to equilibrate with the pH of the irrigation water. Those pH values are usually above 8.0 during the irrigation season as Figures 25 and 26 show. Figure 27 shows the bicarbonate ion concentration in the soil which coincides with the pH values from plot 50, 1982. Notice the drastic reduction in HCO_3^- concentrations both in the soil and in the water when the pH_{iw} went up sharply.

Drainage Water Quantity

This part of the study was the most difficult aspect to obtain

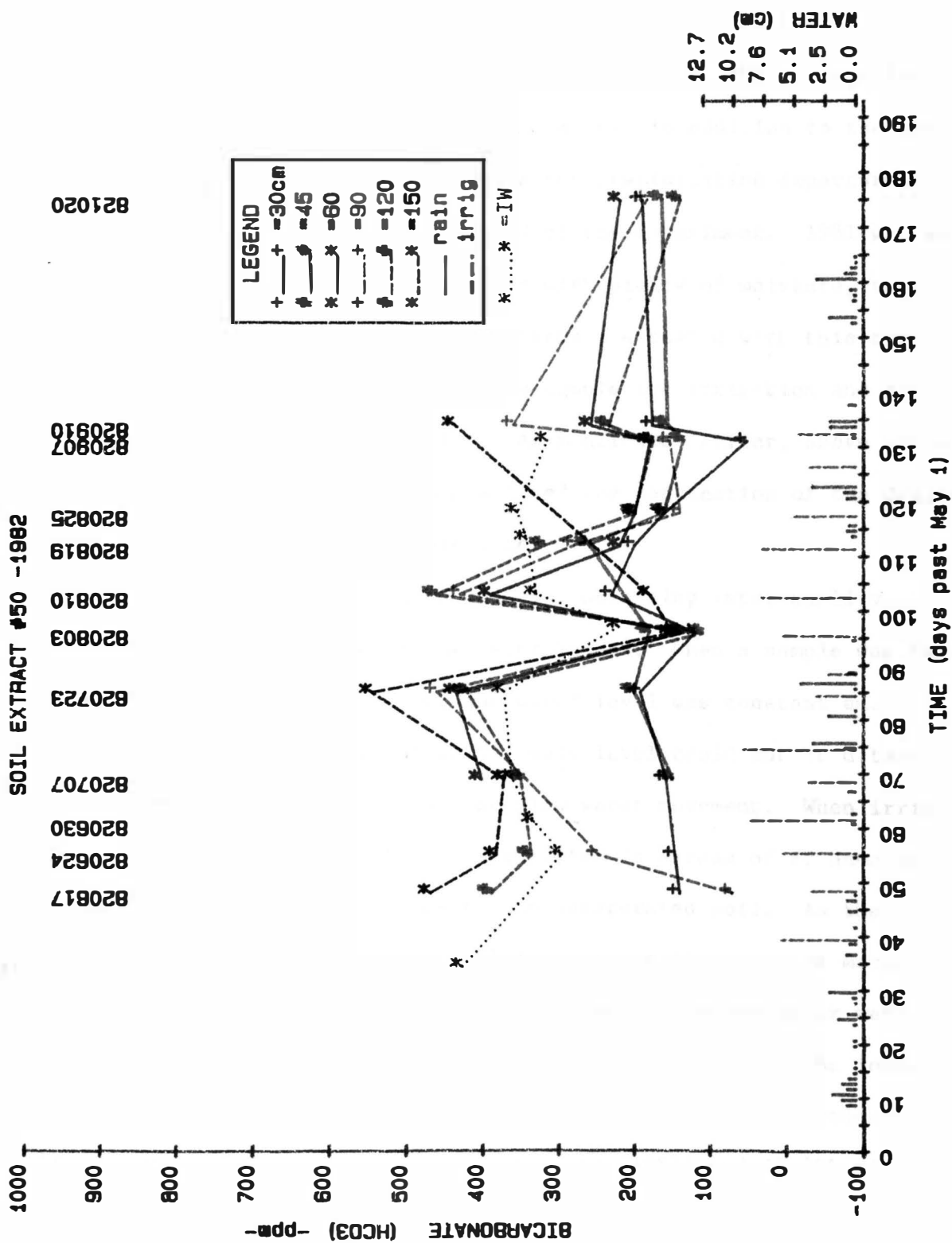

Figure 27. Bicarbonate ion concentration in the soil with depth and time in plot 50, 1982.

real absolute numbers for. The application of water to the 50 and 35G plots caused water table problems at the end of the 1981 irrigation season. The rates of 50, 89, and 127 cm were in addition to the precipitation received. Figure 28 shows the precipitation departures from the normal for the 3-year period of the experiment. 1981 was an exceptionally dry year and 1982 began with plenty of moisture, therefore, the full range of rainfall patterns was tested with this type of irrigation management. Table 5 gives cumulative irrigation and rainfall plus the total for each plot. As mentioned earlier, above normal rainfall and high water tables prevented the application of the desired amounts of wastewater to the plots for 1982.

The observation wells were used for obtaining water quality samples in addition to recording water levels. When a sample was taken on plot 50, the rate of rise of the water level was constant and very slow (Figure 29). The actual water table level could not be determined from this well because of the slow water movement. When irrigation first began, most of the applied water in excess of ET demands went to filling the pore spaces of the unsaturated soil. As those pore spaces became filled, the ability of the soil to accept more water dwindled and run-off increased. Visual signs of excess water were evident at the end of the second year. Alfalfa plants in the lower areas were yellowing and lost either to poor aeration or disease or both. The situation worsened the next year (1982) and 15-20% of the alfalfa stand was estimated to have been lost to water logging problems.

Based upon the recharge in the well from the recording information, plot 50 in 1981 had a .033 cm/hr water level rise rate. When soil

HURON PRECIP DEPARTURES 1980, 81, 82

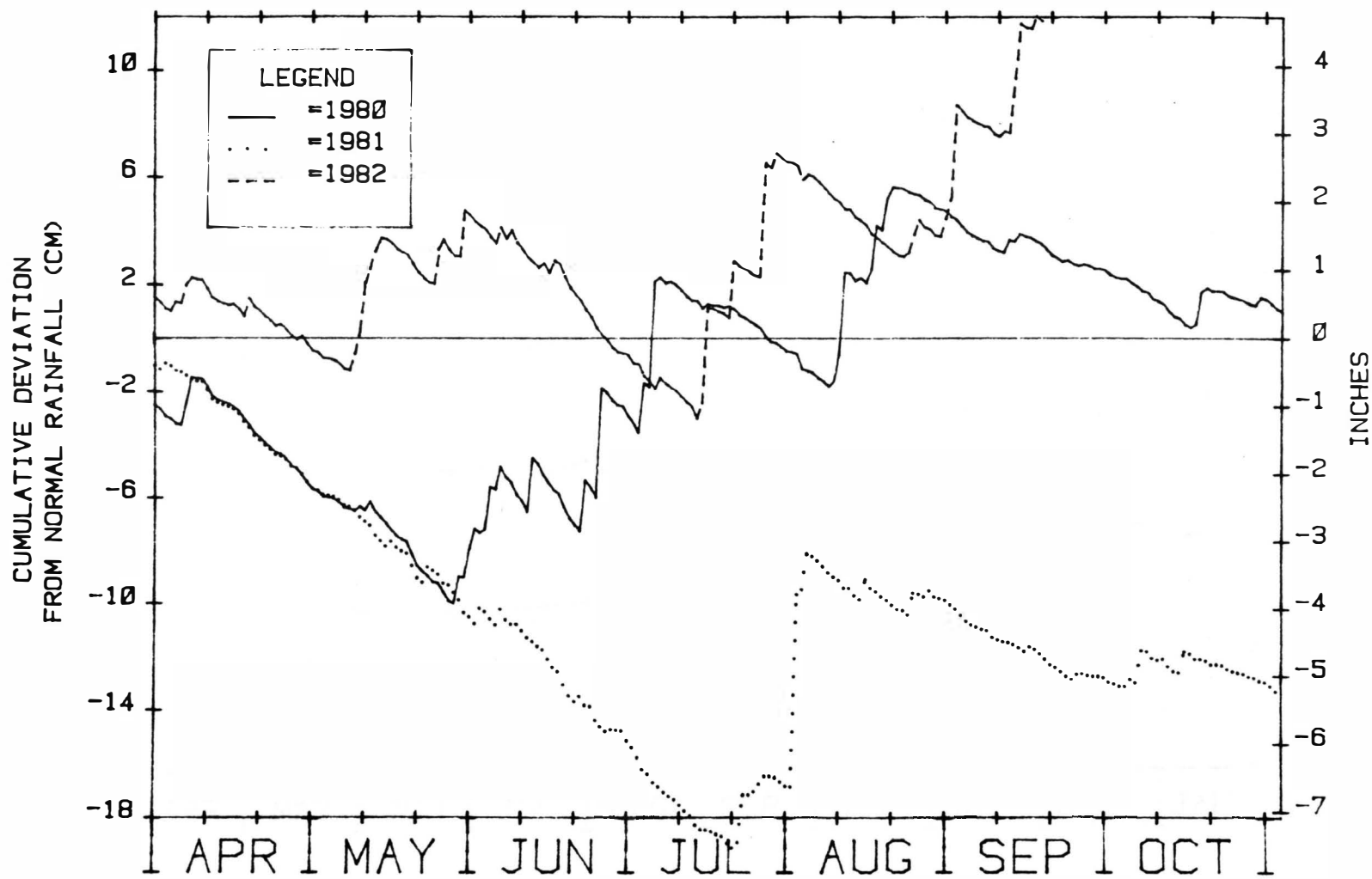

Figure 28. Cumulative precipitation departures from the 1941-1970 average normal of 40.6 cm (16 inches) for Huron, S.D. 1980-1982.

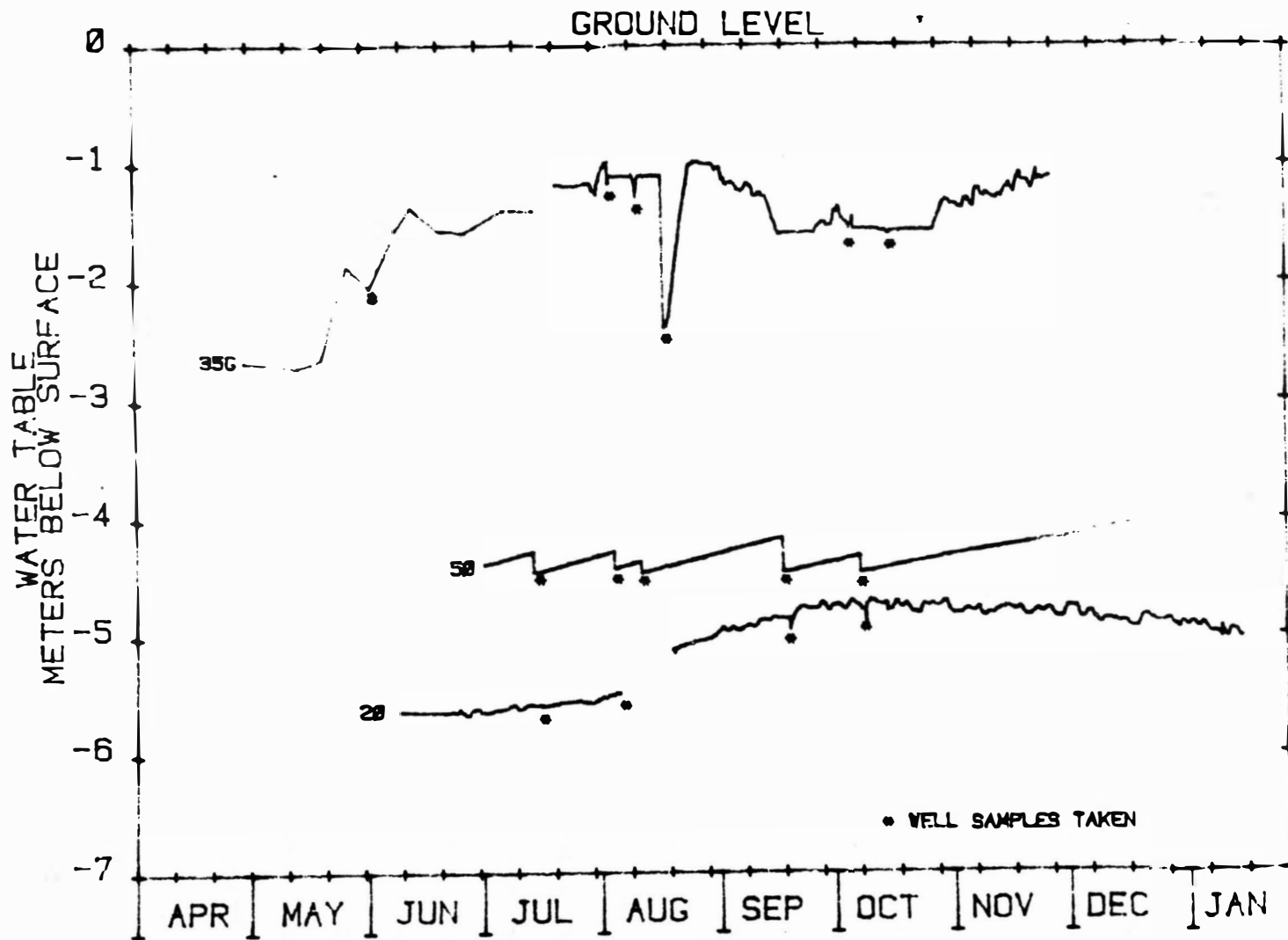

Figure 29. Water table fluctuations obtained from observation wells during the 1981 season for the various treatments.

moisture readings were taken on each plot, water first appeared in the neutron access tubes on both plot 50 and 35G on May 26, 1981. Water levels were taken periodically in those tubes and were assumed to be the actual water table level, assuming there was a hydraulic connection from there to the bottom of the observation well (4.5 meters). When the tube was evacuated of water, it always reappeared. At the end of the 1981 season the water level was within 1.1 meters of the surface on plot 50 and 1.2 meters on plot 35G.

Over the '81-'82 winter the water level in the access tube dropped 40 cm, but was still present in the tube after 215 days of no irrigation. Precipitation during that interval was 9.8 cm and the ET was estimated at 12.7 cm. At the end of the 1982 irrigation season, the water level in the neutron access tube on plot 50 was within .67 meters of the soil surface. The run-off appeared to increase as years of irrigation increased. It was evident, then, that the plot was hydraulically overloaded and with continued years of irrigation using this kind of management the run-off would be severe, the water table would reach the surface, and, eventually, the entire crop would be lost.

Over the winter ('81-'82) the level in the well on plot 35G dropped 1.0 meter. The 35G plot started 1982 (April 27) with water in the well at 2.18 meters below the surface but by September 20 the water table had risen to .76 meters below ground level, higher than any previous year.

This occurred even though the total water received on the plot was 11 cm less than in 1981. Again, it appeared that plot 35G was receiving too much moisture to safely allow that annual hydraulic

loading rate. A plow furrow which ran the length of the plot displayed yellowing alfalfa before the harvest of the 4th cutting of alfalfa. If this loading rate were to continue, problems with a water table and plant losses would soon be evident.

Plot 35 had increases in the water level in the well, also (from 2.77 to 2.09 meters in 1982), however, the water was not as near to the surface as plot 50 and 35G. There may have been more lateral water movement on this plot because of the sand layer below 1 meter, thus, the lower water levels.

Plot 20 had a water table at 5.60 meters below the surface on June 8, 1981. The level began to rise over the irrigation season and peaked out at the last irrigation on September 29, 1982 at 4.7 meters (a rise of .90 meters). The level then began to drop to 5.31 meters beginning a new irrigation season in 1982 (April 27, 1982). From that date the level, again, went up over the irrigation season and was still rising on September 20, 1982 (last records available). On that date the level was 4.57 meters below the surface. For comparison purposes, the 1981 total water (irrigation plus rainfall) on plot 20 was 70 cm while the 1982 total was 75 cm.

If a drainable porosity index of .05 is used to calculate the depth of water leached which would contribute to a 13 cm rise in the water table (from September 29, 1981 to September 20, 1982), then, assuming steady state conditions,

$$13 \text{ cm} \times .05 = .65 \text{ cm (water lost to leaching)}$$

This means that if .65 cm of water was leached to the groundwaters it would cause a 13 cm rise in the water table. This amount is smaller

than the error which could easily occur in estimating the ET. Therefore, on the basis of this information, it is conceivable that annual applications of 50 cm per year of effluent could be applied to this soil for a 20-25 year time frame without causing any serious water table problems when growing alfalfa in this climate.

SUMMARY AND CONCLUSIONS

The feasibility of using land treatment by irrigation as an alternative for disposal of municipal effluent from Huron's unchlorinated stabilization ponds has two main problems.

The first problem is that the high sodium adsorption ratio in the effluent, which will cause soil dispersion and decreased soil permeability, must be decreased. This can be achieved either of two ways. First, the amount of sodium in the effluent can be reduced. This is not an easy solution. However, if the city is considering land treatment as an alternative, the feasibility of reducing the sodium hazard of the effluent should be investigated. Also, the economic benefit to a community of increased production because of irrigation has to be considered in the cost-benefit analysis. Second, a source of soluble calcium could be mixed with the wastewater just prior to irrigation to reduce sodium adsorption by the soil exchange complex. However, this would increase the total salt load of the effluent. The resultant increase in total salt would require crops considered as moderately tolerant-tolerant to salt.

The second problem is that the hydraulic conductivity of the subsoil is too low to allow leaching fractions higher than 8-10%, yet higher amounts are necessary to control the sodium dispersion hazard. The alternative to this would be to install subsurface drain tile on the land area involved. Drain tile effluent would then have to be discharged to some point.

For the years 1980, 1981 and 1982, no significant differences of

dry matter alfalfa yields were found between 50, 89, and 127 cm of annual applications of wastewater in addition to rainfall. Plant population reductions were beginning to appear on both 50 and 35G because of water table problems. During a dry precipitation year (1981) there was a significant reduction in dry matter alfalfa yield on plot 20 (50 cm effluent).

Average three year leaching fractions of the treatments, based on total water applied (plus rainfall) and evapotranspiration estimates, are 0.085 (treatment 20), 0.30 (treatments 35 and 35G), and 0.45 (treatment 50). However, much of the excess water on the two high rate plots went to filling pore spaces and raising the water table. In addition to this, the highest rate plot (127 cm effluent) had significant amounts of run-off in the latter part of the last two irrigation seasons.

Treatments 20 and 50 had the lowest nitrate levels (0-1.3 ppm) in the observation wells. Treatments 35 and 35G had the highest levels (.1-10.1 ppm) of nitrates appearing in the wells. The plot with the most amount of sand in the subsoil (plot 35) had the highest consistent level of nitrates of any of the plots.

Un-incorporated annual autumn gypsum applications to the soil caused no significant reduction in exchangeable sodium percentage (ESP) over the untreated plots. This was based on two applications to plot 35G and one application to half of plot 20 (plot 20G). However, higher concentrations of sodium and magnesium were evident in the observation well from plot 35G. This indicates that the calcium is exchanging with some sodium and magnesium, keeping it off the exchange complex at lower depths in the soil.

No significant difference was found among treatments for the saturated hydraulic conductivity ($K(\theta_s)$) of the surface 3 cm of soil. However, dispersion of soil particles from test cores was clearly evident on plot 20 but not on the other treatments.

When comparing treatment soil $K(\theta_s)$ by laboratory methods, identical pressure heads should be used to arrive at hydraulic conductivity value. Hysteresis, variable channeling, and variations of physical distortions of soil particles do cause the relationship in Darcy's law to deviate from linearity in dealing with large pressure head differences.

There were differences in bulk densities at the 0-3 cm depth between the irrigated soils and the check plot. Significant differences between the check and plot 50 and between the check and plot 20G were found at the .05 level. Bulk densities were higher on treatments 20G and 50 than on the check plot. Plot 35 had significantly higher bulk densities than the check at the .01 level.

Bulk density samples and laboratory saturated hydraulic conductivity cores for testing should total at least 12 to obtain reliable information in determining differences between treatments. Soil variability of these two soil characteristics are usually quite high. Therefore, sampling quantities should increase according to natural variability.

REFERENCES

1. "Process Design Manual for Land Treatment of Municipal Wastewater", U.S. Environmental Protection Agency, U.S. Army Corps of Engineers, U.S. Department of Agriculture, October 1977.
2. "Suitability of Lagoon Effluents for Irrigation in South Dakota", Completion report, September 1976, OWRT Agreement No. 14-34-0001-6043, Project No. A-052-SDAK.
3. Rhoades, J. D. "Leaching Requirements for Exchangeable Sodium Control". Soil Sci. Soc. Amer. Proc. 32:652-656. 1968.
4. McNeal, B. L., D. A. Layfield, W. A. Norvell, and J. D. Rhoades. "Factors Influencing Hydraulic Conductivity of Soils in the Presence of Mixed-Salt Solutions", Soil Sci. Soc. Amer. Proc., Vol. 32, 1968.
5. Quirk, J. P. and R. K. Schofield, "The Effect of Electrolyte Concentration on Soil Permeability". Journal of Soil Science, Vol. 6, No. 2, 1955.
6. McNeal, B. L., and N. T. Coleman, "Effect of Solution Composition on Soil Hydraulic Conductivity", Soil Sci. Soc. Amer. Proc., Vol. 30, 1966.
7. Marten, C. G., C. E. Clapp, and W. E. Larson. "Effects of Municipal Wastewater Effluent and Cutting Management on Persistence and Yield of Eight Perennial Forages", Agron. Journ. Vol. 71, July-Aug. 1979, pp. 650-658.
8. Clapp, C. E., D. R. Linden, W. E. Larson, C. G. Marten, and J. R. Nylund. "Nitrogen Removal from Municipal Wastewater Effluent by a Crop Irrigation System". Proc. of the 1976 Cornell Agricultural Waste Management Conference.
9. Clapp, C. E., A. J. Palazzo, W. E. Larson, G. C. Marten, D. R. Linden. "Uptake of Nutrients by Plants Irrigated with Municipal Wastewater Effluent". Intern. Symposium, Proc. Land Treatment of Wastewater, Hanover, New Hampshire, Aug. 20-25, 1978, Vol. 1.
10. Marten, G. C., W. E. Larson, and C. E. Clapp. "Effects of Municipal Wastewater Effluent on Performance and Feed Quality of Maize vs. Reed Canarygrass". Jour. of Envir. Qual. Vol. 9, No. 1, Jan.-Mar. 1980.
11. Karlen, D. L., M. L. Vitosh, and R. J. Kunze. "Irrigation of Corn with Simulated Municipal Sewage Effluent". J. Environ. Qual., Vol. 5, No. 3, 1976.

12. Adriano, D. C., L. T. Novak, A. E. Erickson, A. R. Wolcott, and B. G. Ellis. "Effect of Long Term Land Disposal by Spray Irrigation of Food Processing Wastes on Some Chemical Properties of the Soil and Subsurface Water". J. Environ. Qual., Vol. 4, no. 2, 1975.
13. Bole, J. B., and R. G. Bell. "Land Application of Municipal Sewage Wastewater: Yield and Chemical Composition of Forage Crops". J. Environ. Qual., Vol. 7, no. 2, 1978.
14. Ellis, B. G., and A. E. Erickson. 1971. "The Nutrient Content of Drainage Water from Agricultural Land". Res. Bull. No. 31. Michigan State Agric. Exp. Stn., Michigan State Univ., East Lansing, Mich. 16 p.
15. U.S. Salinity Laboratory Staff. 1954. Diagnosis and improvement of saline and alkali soils. U.S. Dept. Agr. Handbook 60, 160 p.
16. Brosz, D. D. and J. L. Wiersma, "Scheduling Irrigations Using Average Climatic Data". 1970 North Central Region American Society of Agric. Engineers Proc., Paper No. NC70-201.
17. Van Schilfgaarde, J. Drainage for Agriculture. Am. Soc. of Agronomy Monograph No. 17, 1974.
18. Keren, R. and G. A. O'Connor. "Gypsum Dissolution and Sodic Soil Reclamation as Affected by Water Flow Velocity". Soil Sci. Soc. Amer. Proc., Vol. 46, 1982.
19. Black, C. A., D. D. Evans, J. L. White, L. E. Ensminger, and F. E. Clark. Methods of Soil Analysis: Physical and Mineralogical Properties, Including Statistics of Measurement and Sampling. American Society of Agronomy No. 9. 1965.

APPENDIX

Appendix A. Laboratory-determined parameters of field soil water
extracts 1980.

Nitrate
pH
Total Phosphate
Ammonia
Sodium
Chloride
Bicarbonate
Electrical Conductivity

SOIL EXTRACT ANALYSIS 1980-1982

NITRATE (as N) -ppm-

PLOT 5J 1980

| DATE | DEPTH (cm) | | | | | |
|--------|------------|------|------|-------|-------|------|
| | 30 | 45 | 60 | 90 | 120 | 150 |
| 800820 | 0.17 | 4.90 | 0.03 | 26.00 | 11.00 | 4.25 |
| 800814 | 0.10 | 4.40 | 0.11 | ---- | ---- | ---- |
| 800829 | 0.10 | 1.35 | 0.07 | 4.90 | 4.75 | 2.40 |
| 800911 | 12.50 | 1.60 | 0.06 | 0.04 | 0.04 | ---- |
| 800917 | ---- | ---- | ---- | ---- | ---- | ---- |
| 800926 | 0.07 | ---- | 1.38 | 0.31 | ---- | ---- |
| 801003 | ---- | 3.00 | ---- | 1.14 | 9.25 | 1.76 |
| 801008 | 2.95 | 2.70 | 0.75 | ---- | 1.43 | 1.21 |
| 801023 | 2.50 | 3.78 | 1.80 | ---- | 0.66 | 0.80 |
| 801104 | 3.02 | ---- | 9.75 | ---- | 1.21 | ---- |

NITRATE (as N) -ppm-

PLOT 35G 1980

| DATE | DEPTH (cm) | | | | | |
|--------|------------|-------|------|-------|------|-------|
| | 30 | 45 | 60 | 90 | 120 | 150 |
| 800820 | 3.90 | ---- | 0.22 | 2.30 | ---- | 29.00 |
| 800814 | ---- | ---- | ---- | ---- | ---- | ---- |
| 800829 | 0.07 | ---- | 0.16 | 4.88 | 0.03 | 9.00 |
| 800911 | 0.27 | 16.75 | 0.05 | 12.50 | 0.03 | 1.40 |
| 800917 | ---- | ---- | ---- | 14.25 | 0.03 | ---- |
| 800926 | 14.55 | 1.14 | 1.10 | 13.00 | ---- | ---- |
| 801003 | 19.00 | ---- | 0.47 | 7.50 | 0.06 | 0.01 |
| 801008 | 3.68 | ---- | 0.04 | 7.38 | ---- | 0.02 |
| 801023 | 9.00 | 0.37 | 2.64 | 6.55 | 0.02 | 0.00 |
| 801104 | ---- | 0.75 | ---- | 1.48 | 0.09 | 0.83 |

NITRATE (as N) -ppm-

PLOT 35 1980

| DATE | DEPTH (cm) | | | | | |
|--------|------------|------|------|-------|-------|------|
| | 30 | 45 | 60 | 90 | 120 | 150 |
| 800820 | 0.10 | 3.70 | 1.10 | ---- | ---- | ---- |
| 800814 | ---- | ---- | ---- | ---- | ---- | ---- |
| 800829 | 0.04 | 0.04 | 0.23 | ---- | ---- | ---- |
| 800911 | 0.01 | 0.03 | 0.04 | ---- | ---- | ---- |
| 800917 | ---- | ---- | ---- | ---- | ---- | ---- |
| 800926 | ---- | ---- | ---- | 17.50 | 13.92 | ---- |
| 801003 | 2.40 | 5.50 | ---- | 12.38 | 9.62 | ---- |
| 801008 | ---- | 1.00 | 2.04 | 0.14 | 11.35 | ---- |
| 801023 | 0.95 | ---- | 1.75 | 2.20 | 2.76 | ---- |
| 801104 | 1.21 | ---- | 1.48 | 0.00 | ---- | ---- |

NITRATE (as N) -ppm-

PLOT 20 1980

| DATE | DEPTH (cm) | | | | | |
|--------|------------|------|------|------|------|-------|
| | 30 | 45 | 60 | 90 | 120 | 150 |
| 800820 | ---- | ---- | ---- | ---- | ---- | ---- |
| 800814 | ---- | ---- | ---- | ---- | ---- | ---- |
| 800829 | ---- | 0.38 | 0.10 | ---- | ---- | ---- |
| 800911 | ---- | 0.04 | 0.02 | ---- | 0.04 | ---- |
| 800917 | ---- | ---- | ---- | ---- | ---- | ---- |
| 800926 | ---- | ---- | ---- | ---- | ---- | 14.38 |
| 801003 | ---- | ---- | ---- | ---- | ---- | 16.12 |
| 801008 | ---- | ---- | ---- | ---- | ---- | 14.00 |
| 801023 | ---- | ---- | ---- | 0.00 | ---- | 14.30 |
| 801104 | ---- | ---- | 2.15 | 1.16 | ---- | 14.50 |

PH

PLOT 50 1980

| DATE | DEPTH (cm) | | | | | |
|--------|------------|------|------|------|------|------|
| | 30 | 45 | 60 | 90 | 120 | 150 |
| 800820 | 8.15 | 8.25 | 8.00 | 8.30 | 8.59 | 8.35 |
| 800814 | 8.25 | 8.20 | 8.10 | ---- | ---- | ---- |
| 800829 | 8.17 | 8.26 | 8.02 | 8.06 | 8.09 | 8.28 |
| 800911 | ---- | ---- | ---- | 8.35 | ---- | ---- |
| 800917 | ---- | ---- | ---- | ---- | ---- | ---- |
| 800926 | 8.31 | ---- | 7.92 | 8.31 | ---- | ---- |
| 801003 | ---- | 8.15 | ---- | 8.19 | 8.31 | 8.43 |
| 801008 | 8.30 | 8.20 | 8.19 | ---- | 8.30 | 8.40 |
| 801023 | 8.16 | 8.28 | 8.50 | ---- | 8.25 | 8.36 |
| 801104 | 8.30 | ---- | 8.31 | ---- | 8.18 | ---- |

PH

PLOT 35G 1980

| DATE | DEPTH (cm) | | | | | |
|--------|------------|------|------|------|------|------|
| | 30 | 45 | 60 | 90 | 120 | 150 |
| 800820 | 8.60 | ---- | 8.04 | 8.05 | ---- | 8.13 |
| 800814 | ---- | ---- | ---- | ---- | ---- | ---- |
| 800829 | 7.58 | ---- | 7.82 | 8.04 | 8.38 | 8.16 |
| 800911 | ---- | ---- | 8.18 | 8.64 | 9.88 | 8.92 |
| 800917 | ---- | ---- | ---- | 7.61 | 8.19 | ---- |
| 800926 | 8.23 | 8.19 | 8.15 | 8.63 | ---- | ---- |
| 801003 | 8.25 | ---- | 8.09 | 8.40 | 8.89 | 8.90 |
| 801008 | 8.22 | ---- | 8.09 | 8.65 | ---- | 8.90 |
| 801023 | 8.51 | 8.12 | 8.00 | 8.59 | 8.80 | 8.85 |
| 801104 | ---- | 7.99 | ---- | 8.50 | 8.80 | 8.80 |

PH PLOT 35 1980

| DATE | DEPTH (cm) | | | | | |
|--------|------------|------|------|------|------|------|
| | 30 | 45 | 60 | 90 | 120 | 150 |
| 800820 | 7.90 | 8.50 | 8.12 | ---- | ---- | ---- |
| 800814 | ---- | ---- | ---- | ---- | ---- | ---- |
| 800829 | 8.00 | 7.30 | 7.89 | ---- | ---- | ---- |
| 800911 | ---- | ---- | ---- | ---- | ---- | ---- |
| 800917 | ---- | ---- | ---- | ---- | ---- | ---- |
| 800926 | ---- | ---- | ---- | 8.32 | 8.23 | ---- |
| 801003 | 8.30 | 8.10 | ---- | 8.23 | 8.30 | ---- |
| 801003 | ---- | 8.15 | 8.08 | 8.30 | 3.22 | ---- |
| 801023 | 8.01 | ---- | 7.92 | 8.30 | ---- | ---- |
| 801104 | 8.01 | ---- | 7.72 | 8.40 | ---- | ---- |

PH PLOT 20 1980

| DATE | DEPTH (cm) | | | | | |
|--------|------------|------|------|------|------|------|
| | 30 | 45 | 60 | 90 | 120 | 150 |
| 800820 | ---- | ---- | ---- | ---- | ---- | ---- |
| 800814 | ---- | ---- | ---- | ---- | ---- | ---- |
| 800829 | ---- | 8.04 | 8.30 | ---- | ---- | ---- |
| 800911 | ---- | ---- | ---- | ---- | ---- | ---- |
| 800917 | ---- | ---- | ---- | ---- | ---- | ---- |
| 800926 | ---- | ---- | ---- | ---- | ---- | 8.00 |
| 801003 | ---- | ---- | ---- | ---- | ---- | 8.12 |
| 801003 | ---- | ---- | ---- | ---- | ---- | 8.12 |
| 801023 | ---- | ---- | ---- | 8.55 | ---- | 3.13 |
| 801104 | ---- | ---- | 8.00 | 8.70 | ---- | 3.18 |

T-PO4 as P -ppm-

PLOT 50 1980

| DATE | DEPTH (cm) | | | | | |
|--------|------------|------|------|------|------|------|
| | 30 | 45 | 60 | 90 | 120 | 150 |
| 800820 | 0.03 | 0.02 | 0.04 | 0.30 | 0.05 | 0.03 |
| 800814 | 0.14 | 0.04 | 0.09 | ---- | ---- | ---- |
| 800829 | ---- | 0.01 | 0.02 | 0.10 | 0.03 | 0.01 |
| 800911 | ---- | ---- | ---- | ---- | ---- | ---- |
| 800917 | ---- | ---- | ---- | ---- | ---- | ---- |
| 800926 | 0.03 | ---- | 0.01 | 0.01 | ---- | ---- |
| 801003 | ---- | 0.02 | ---- | 0.01 | 0.02 | 0.00 |
| 801008 | ---- | 0.02 | ---- | ---- | 0.02 | 0.02 |
| 801023 | 0.02 | 0.23 | ---- | ---- | 0.00 | 0.01 |
| 801104 | 0.16 | ---- | ---- | ---- | 0.06 | ---- |

T-PO4 as P -ppm-

PLOT 35G 1980

| DATE | DEPTH (cm) | | | | | |
|--------|------------|------|------|------|------|------|
| | 30 | 45 | 60 | 90 | 120 | 150 |
| 800820 | 0.23 | ---- | 0.04 | 0.05 | ---- | 0.02 |
| 800814 | ---- | ---- | ---- | ---- | ---- | ---- |
| 800829 | 0.00 | ---- | 0.00 | 0.00 | ---- | 0.00 |
| 800911 | ---- | ---- | 0.01 | 0.00 | 0.01 | 0.00 |
| 800917 | ---- | ---- | ---- | ---- | 0.01 | ---- |
| 800926 | 0.04 | 0.02 | 0.05 | 0.00 | ---- | ---- |
| 801003 | ---- | ---- | 0.02 | 0.01 | 0.02 | 0.01 |
| 801008 | ---- | ---- | ---- | 0.03 | ---- | 0.02 |
| 801023 | ---- | 0.05 | 0.13 | 0.02 | 0.03 | 0.02 |
| 801104 | ---- | 0.04 | ---- | 0.03 | 0.03 | 0.03 |

T-PO4 as P -ppm-

PLOT 35 1980

| DATE | DEPTH (cm) | | | | | |
|--------|------------|------|------|------|------|------|
| | 30 | 45 | 60 | 90 | 120 | 150 |
| 800820 | 0.12 | 0.25 | 0.05 | ---- | ---- | ---- |
| 800814 | ---- | ---- | ---- | ---- | ---- | ---- |
| 800829 | 0.00 | 0.01 | 0.00 | ---- | ---- | ---- |
| 800911 | ---- | ---- | ---- | ---- | ---- | ---- |
| 800917 | ---- | ---- | ---- | ---- | ---- | ---- |
| 800926 | ---- | ---- | ---- | ---- | ---- | ---- |
| 801003 | ---- | ---- | ---- | ---- | 0.02 | ---- |
| 801008 | ---- | ---- | 0.02 | ---- | 0.07 | ---- |
| 801023 | 0.07 | ---- | 0.02 | 0.10 | ---- | ---- |
| 801104 | ---- | ---- | 0.05 | ---- | ---- | ---- |

T-PO4 as P -ppm-

PLOT 20 1980

| DATE | DEPTH (cm) | | | | | |
|--------|------------|------|------|------|------|------|
| | 30 | 45 | 60 | 90 | 120 | 150 |
| 800820 | ---- | ---- | ---- | ---- | ---- | ---- |
| 800814 | ---- | ---- | ---- | ---- | ---- | ---- |
| 800829 | ---- | ---- | ---- | ---- | ---- | ---- |
| 800911 | ---- | ---- | ---- | ---- | ---- | ---- |
| 800917 | ---- | ---- | ---- | ---- | ---- | ---- |
| 800926 | ---- | ---- | ---- | ---- | ---- | ---- |
| 801003 | ---- | ---- | ---- | ---- | ---- | 0.00 |
| 801008 | ---- | ---- | ---- | ---- | ---- | 0.04 |
| 801023 | ---- | ---- | ---- | ---- | ---- | ---- |
| 801104 | ---- | ---- | 0.05 | 0.07 | ---- | 0.05 |

NH3 as N -ppm-

PLOT 50 1980

| DATE | DEPTH (cm) | | | | | |
|--------|------------|------|------|------|------|------|
| | 30 | 45 | 60 | 90 | 120 | 150 |
| 800820 | 0.20 | 0.00 | 0.00 | 0.30 | 0.30 | 0.00 |
| 800814 | 0.40 | 0.50 | 0.00 | ---- | ---- | ---- |
| 800829 | 0.50 | 0.00 | 0.30 | 0.50 | 0.00 | 0.00 |
| 800911 | 0.00 | 0.00 | 0.00 | 0.10 | 0.00 | ---- |
| 800917 | ---- | ---- | ---- | ---- | ---- | ---- |
| 800926 | 0.50 | 0.00 | 0.00 | 0.00 | ---- | ---- |
| 801003 | 0.00 | 0.00 | ---- | 0.00 | 0.00 | 0.00 |
| 801008 | 0.00 | 0.00 | 0.40 | ---- | 0.00 | 0.00 |
| 801023 | 0.00 | 0.00 | 0.00 | ---- | 0.00 | 0.10 |
| 801104 | 0.00 | ---- | 0.00 | ---- | 0.00 | ---- |

NH3 as N -ppm-

PLOT 35G 1980

| DATE | DEPTH (cm) | | | | | |
|--------|------------|------|------|------|------|------|
| | 30 | 45 | 60 | 90 | 120 | 150 |
| 800820 | 0.50 | ---- | 0.40 | 0.10 | ---- | 0.00 |
| 800814 | ---- | ---- | ---- | ---- | ---- | ---- |
| 800829 | 0.50 | ---- | 0.30 | 0.20 | 0.00 | 0.00 |
| 800911 | 0.00 | 0.10 | 0.10 | 0.20 | 0.00 | 0.30 |
| 800917 | ---- | ---- | ---- | 0.70 | 0.00 | ---- |
| 800926 | 0.20 | 0.10 | 0.20 | 0.00 | ---- | ---- |
| 801003 | 0.10 | 0.00 | 0.10 | 0.10 | 0.00 | 0.10 |
| 801008 | 0.10 | ---- | 0.00 | 0.00 | ---- | 0.00 |
| 801023 | 0.20 | 0.00 | 0.00 | 0.00 | 0.00 | 0.20 |
| 801104 | ---- | 0.50 | ---- | 0.20 | 0.00 | 0.00 |

NH3 as N -ppm-

PLOT 35 1980

| DATE | DEPTH (cm) | | | | | |
|--------|------------|------|------|------|------|------|
| | 30 | 45 | 60 | 90 | 120 | 150 |
| 800820 | 0.40 | 1.00 | 1.00 | ---- | ---- | ---- |
| 800814 | ---- | ---- | ---- | ---- | ---- | ---- |
| 800829 | 0.10 | 1.00 | 1.20 | ---- | ---- | ---- |
| 800911 | 0.00 | 0.00 | 0.10 | ---- | ---- | ---- |
| 800917 | ---- | ---- | ---- | ---- | ---- | ---- |
| 800926 | ---- | ---- | ---- | 0.50 | 0.20 | ---- |
| 801003 | 0.10 | 0.00 | ---- | 0.00 | 0.10 | ---- |
| 801008 | 0.00 | 0.00 | 0.00 | 0.00 | 0.10 | ---- |
| 801023 | 0.00 | ---- | 0.00 | 0.00 | 0.00 | ---- |
| 801104 | 0.00 | ---- | 0.00 | 0.00 | ---- | ---- |

NH₃ as N -ppm-

PLOT 20 1980

| DATE | DEPTH (cm) | | | | | |
|--------|------------|------|------|------|------|------|
| | 30 | 45 | 60 | 90 | 120 | 150 |
| 800820 | ---- | ---- | ---- | ---- | ---- | ---- |
| 800814 | ---- | ---- | ---- | ---- | ---- | ---- |
| 800829 | ---- | 1.30 | 0.60 | ---- | ---- | ---- |
| 800911 | ---- | 0.00 | 0.00 | ---- | 0.00 | ---- |
| 800917 | ---- | ---- | ---- | ---- | ---- | ---- |
| 800926 | ---- | ---- | ---- | ---- | ---- | 0.00 |
| 801003 | ---- | ---- | ---- | ---- | ---- | 0.00 |
| 801008 | ---- | ---- | ---- | ---- | ---- | 0.00 |
| 801023 | ---- | 0.00 | ---- | 1.00 | ---- | 0.00 |
| 801104 | 0.00 | ---- | 0.10 | 0.20 | ---- | 0.00 |

SODIUM (Na) -ppm-

PLOT 50 1980

| DATE | DEPTH (cm) | | | | | |
|--------|------------|-------|--------|------|------|------|
| | 30 | 45 | 60 | 90 | 120 | 150 |
| 800820 | 185.0 | 91.0 | 186.0 | 24.0 | 38.0 | 21.0 |
| 800814 | 131.0 | 53.0 | 93.0 | ---- | ---- | ---- |
| 800829 | 170.0 | 118.0 | 195.0 | 10.0 | 35.0 | 11.0 |
| 800911 | 99.0 | 138.0 | 210.0 | 14.0 | 37.0 | ---- |
| 800917 | ---- | ---- | ---- | ---- | ---- | ---- |
| 800926 | 277.0 | 200.0 | 297.0 | 13.0 | ---- | ---- |
| 801003 | 253.0 | 261.0 | ---- | 26.0 | 73.0 | 24.0 |
| 801008 | 440.0 | 377.0 | 725.0 | ---- | 51.0 | 42.0 |
| 801023 | 330.0 | 239.0 | 430.0 | ---- | 53.0 | 46.0 |
| 801104 | 333.0 | ---- | 1620.0 | ---- | 61.0 | ---- |

SODIUM (Na) -ppm-

PLOT 35G 1980

| DATE | DEPTH (cm) | | | | | |
|--------|------------|-------|-------|------|------|------|
| | 30 | 45 | 60 | 90 | 120 | 150 |
| 800820 | 253.0 | ---- | 230.0 | 45.0 | ---- | 61.0 |
| 800814 | ---- | ---- | ---- | ---- | ---- | ---- |
| 800829 | 231.0 | ---- | 279.0 | 23.0 | 30.0 | 45.0 |
| 800911 | 224.0 | 224.0 | 294.0 | 17.0 | 27.0 | 52.0 |
| 800917 | ---- | ---- | ---- | 35.0 | 25.0 | ---- |
| 800926 | 353.0 | 254.0 | 449.0 | 45.0 | ---- | ---- |
| 801003 | 433.0 | 348.0 | 423.0 | 37.0 | 26.0 | 59.0 |
| 801008 | 430.0 | ---- | 460.0 | 47.0 | ---- | 35.0 |
| 801023 | 530.0 | 109.0 | 630.0 | 59.0 | 34.0 | 66.0 |
| 801104 | ---- | 420.0 | ---- | 53.0 | 39.0 | 52.0 |

SODIUM (Na) -ppm-

PLOT 35 1980

| DATE | DEPTH (cm) | | | | | |
|--------|------------|-------|-------|------|-------|------|
| | 30 | 45 | 60 | 90 | 120 | 150 |
| 800820 | 237.0 | 196.0 | 147.0 | ---- | ---- | ---- |
| 800814 | ---- | ---- | ---- | ---- | ---- | ---- |
| 800829 | 303.0 | 190.0 | 167.0 | ---- | ---- | ---- |
| 800911 | 243.0 | 210.0 | 205.0 | ---- | ---- | ---- |
| 800917 | ---- | ---- | ---- | ---- | ---- | ---- |
| 800926 | ---- | ---- | ---- | 42.0 | 28.0 | ---- |
| 801003 | ---- | 251.0 | ---- | 30.0 | 24.0 | ---- |
| 801003 | ---- | 640.0 | 322.0 | 35.0 | 42.0 | ---- |
| 801023 | 540.0 | ---- | 321.0 | 45.0 | 150.0 | ---- |
| 801104 | 1030.0 | ---- | 450.0 | 34.0 | ---- | ---- |

SODIUM (Na) -ppm-

PLOT 20 1980

| DATE | DEPTH (cm) | | | | | |
|--------|------------|------|-------|-------|-------|--------|
| | 30 | 45 | 60 | 90 | 120 | 150 |
| 800820 | ---- | ---- | ---- | ---- | ---- | ---- |
| 800814 | ---- | ---- | ---- | ---- | ---- | ---- |
| 800829 | ---- | 40.0 | 25.0 | ---- | ---- | ---- |
| 800911 | ---- | 53.0 | 35.0 | ---- | 130.0 | ---- |
| 800917 | ---- | ---- | ---- | ---- | ---- | ---- |
| 800926 | ---- | ---- | ---- | ---- | ---- | 690.0 |
| 801003 | ---- | ---- | ---- | ---- | ---- | 780.0 |
| 801003 | ---- | ---- | ---- | ---- | ---- | 2360.0 |
| 801023 | ---- | ---- | ---- | 137.0 | ---- | 1530.0 |
| 801104 | 12200.0 | ---- | 450.0 | 109.0 | ---- | 1350.0 |

CHLORIDE (Cl) -ppm-

PLOT 50 1980

| DATE | DEPTH (cm) | | | | | |
|--------|------------|--------|--------|-------|-------|-------|
| | 30 | 45 | 60 | 90 | 120 | 150 |
| 800820 | 440.0 | 435.0 | 670.0 | 370.0 | 405.0 | 480.0 |
| 800814 | 505.0 | 418.0 | 340.0 | ---- | ---- | ---- |
| 800829 | 315.0 | 305.0 | 388.0 | 432.0 | 415.0 | 385.0 |
| 800911 | ---- | 525.0 | ---- | 600.0 | ---- | ---- |
| 800917 | ---- | ---- | ---- | ---- | ---- | ---- |
| 800926 | 700.0 | 1075.0 | 1050.0 | 550.0 | ---- | ---- |
| 801003 | ---- | 710.0 | ---- | 630.0 | 680.0 | 620.0 |
| 801003 | 690.0 | 550.0 | 1060.0 | ---- | 770.0 | 530.0 |
| 801023 | 510.0 | 480.0 | 805.0 | ---- | 750.0 | 570.0 |
| 801104 | 540.0 | ---- | 1630.0 | ---- | 720.0 | ---- |

CHLORIDE (Cl) -ppm-

PLOT 35G 1980

| DATE | DEPTH (cm) | | | | | |
|--------|------------|-------|--------|-------|-------|-------|
| | 30 | 45 | 60 | 90 | 120 | 150 |
| 800820 | 635.0 | ---- | 590.0 | 505.0 | ---- | 415.0 |
| 800814 | ---- | ---- | ---- | ---- | ---- | ---- |
| 800829 | 305.0 | ---- | 522.0 | 325.0 | 340.0 | 222.0 |
| 800911 | ---- | 900.0 | 625.0 | 338.0 | 412.0 | 300.0 |
| 800917 | ---- | ---- | ---- | 400.0 | 575.0 | ---- |
| 800926 | 535.0 | 675.0 | 875.0 | 400.0 | ---- | ---- |
| 801003 | 700.0 | ---- | 990.0 | 460.0 | 510.0 | 390.0 |
| 801008 | 530.0 | ---- | 1050.0 | 520.0 | ---- | 430.0 |
| 801023 | 710.0 | 710.0 | 1160.0 | 540.0 | 570.0 | 560.0 |
| 801104 | ---- | 760.0 | ---- | 545.0 | 550.0 | 480.0 |

CHLORIDE (Cl) -ppm-

PLOT 35 1980

| DATE | DEPTH (cm) | | | | | |
|--------|------------|-------|-------|-------|--------|------|
| | 30 | 45 | 60 | 90 | 120 | 150 |
| 800820 | 438.0 | 615.0 | 540.0 | ---- | ---- | ---- |
| 800814 | ---- | ---- | ---- | ---- | ---- | ---- |
| 800829 | 335.0 | 365.0 | 408.0 | ---- | ---- | ---- |
| 800911 | ---- | ---- | 575.0 | ---- | ---- | ---- |
| 800917 | ---- | ---- | ---- | ---- | ---- | ---- |
| 800926 | ---- | ---- | ---- | 475.0 | 625.0 | ---- |
| 801003 | 1140.0 | 910.0 | ---- | 530.0 | 505.0 | ---- |
| 801008 | 2220.0 | 900.0 | 710.0 | 530.0 | 710.0 | ---- |
| 801023 | 1000.0 | ---- | 830.0 | 420.0 | 1850.0 | ---- |
| 801104 | 1130.0 | ---- | 780.0 | 390.0 | ---- | ---- |

CHLORIDE (Cl) -ppm-

PLOT 20 1980

| DATE | DEPTH (cm) | | | | | |
|--------|------------|-------|--------|-------|-------|-------|
| | 30 | 45 | 60 | 90 | 120 | 150 |
| 800820 | ---- | ---- | ---- | ---- | ---- | ---- |
| 800814 | ---- | ---- | ---- | ---- | ---- | ---- |
| 800829 | ---- | 715.0 | ---- | ---- | ---- | ---- |
| 800911 | ---- | ---- | 2100.0 | ---- | 250.0 | ---- |
| 800917 | ---- | ---- | ---- | ---- | ---- | ---- |
| 800926 | ---- | ---- | ---- | ---- | ---- | 177.5 |
| 801003 | ---- | ---- | ---- | ---- | ---- | 180.0 |
| 801008 | ---- | ---- | ---- | ---- | ---- | 120.0 |
| 801023 | ---- | ---- | ---- | 505.0 | ---- | 145.0 |
| 801104 | ---- | ---- | 1600.0 | 635.0 | ---- | 118.0 |

BICARBONATE (HCO₃) -ppm- PLOT 50 1980

| DATE | DEPTH (cm) | | | | | |
|--------|------------|-------|-------|-------|-------|-------|
| | 30 | 45 | 60 | 90 | 120 | 150 |
| 800820 | 100.0 | 102.0 | 137.0 | 244.0 | 93.0 | 461.0 |
| 800814 | 49.0 | 56.0 | 117.0 | ---- | ---- | ---- |
| 800829 | 33.0 | 102.0 | 168.0 | 177.0 | 289.0 | 402.0 |
| 800911 | ---- | 140.0 | ---- | ---- | ---- | ---- |
| 800917 | ---- | ---- | ---- | ---- | ---- | ---- |
| 800926 | 120.0 | ---- | 60.0 | 96.0 | ---- | ---- |
| 801003 | ---- | 60.0 | ---- | 38.0 | 112.0 | 123.0 |
| 801008 | 90.0 | 80.0 | 80.0 | ---- | 103.0 | 124.0 |
| 801023 | 60.0 | 136.0 | 210.0 | ---- | 103.0 | 128.0 |
| 801104 | 120.0 | ---- | 240.0 | ---- | 120.0 | ---- |

BICARBONATE (HCO₃) -ppm- PLOT 35G 1980

| DATE | DEPTH (cm) | | | | | |
|--------|------------|-------|-------|-------|-------|-------|
| | 30 | 45 | 60 | 90 | 120 | 150 |
| 800820 | 288.0 | ---- | 532.0 | 535.0 | ---- | 839.0 |
| 800814 | ---- | ---- | ---- | ---- | ---- | ---- |
| 800829 | 77.0 | ---- | 334.0 | 482.0 | 562.0 | 648.0 |
| 800911 | ---- | 100.0 | 30.0 | 180.0 | 403.0 | 454.0 |
| 800917 | ---- | ---- | ---- | 535.0 | 608.0 | ---- |
| 800926 | 96.0 | 33.0 | 34.0 | 172.0 | ---- | ---- |
| 801003 | 90.0 | ---- | 100.0 | 130.0 | 332.0 | 360.0 |
| 801008 | 80.0 | ---- | 90.0 | 174.0 | ---- | 354.0 |
| 801023 | 240.0 | 92.0 | 100.0 | 134.0 | 295.0 | 332.0 |
| 801104 | ---- | 100.0 | ---- | 172.0 | 304.0 | 303.0 |

BICARBONATE (HCO₃) -ppm- PLOT 35 1980

| DATE | DEPTH (cm) | | | | | |
|--------|------------|-------|-------|-------|-------|------|
| | 30 | 45 | 60 | 90 | 120 | 150 |
| 800820 | 146.0 | 232.0 | 101.0 | ---- | ---- | ---- |
| 800814 | ---- | ---- | ---- | ---- | ---- | ---- |
| 800829 | 233.0 | 244.0 | 195.0 | ---- | ---- | ---- |
| 800911 | ---- | ---- | ---- | ---- | ---- | ---- |
| 800917 | ---- | ---- | ---- | ---- | ---- | ---- |
| 800926 | ---- | ---- | ---- | 148.0 | 105.0 | ---- |
| 801003 | 120.0 | 100.0 | ---- | 120.0 | 100.0 | ---- |
| 801008 | ---- | 60.0 | 60.0 | 120.0 | 100.0 | ---- |
| 801023 | 80.0 | ---- | 74.0 | 110.0 | ---- | ---- |
| 801104 | 120.0 | ---- | 80.0 | 220.0 | ---- | ---- |

BICARBONATE (HCO₃) -ppm-

PLOT 20 1930

| DATE | DEPTH (cm) | | | | | |
|--------|------------|-------|-------|-------|------|-------|
| | 30 | 45 | 60 | 90 | 120 | 150 |
| 800820 | ---- | ---- | ---- | ---- | ---- | ---- |
| 800814 | ---- | ---- | ---- | ---- | ---- | ---- |
| 800829 | ---- | 200.0 | 150.0 | ---- | ---- | ---- |
| 800911 | ---- | ---- | ---- | ---- | ---- | ---- |
| 800917 | ---- | ---- | ---- | ---- | ---- | ---- |
| 800926 | ---- | ---- | ---- | ---- | ---- | 104.0 |
| 801003 | ---- | ---- | ---- | ---- | ---- | 40.0 |
| 801008 | ---- | ---- | ---- | ---- | ---- | 120.0 |
| 801023 | ---- | ---- | ---- | ---- | ---- | 103.0 |
| 801104 | ---- | ---- | 100.0 | 235.0 | ---- | 140.0 |

CONDUCTIVITY -mS/cm-

PLOT 50 1930

| DATE | DEPTH (cm) | | | | | |
|--------|------------|------|------|------|------|------|
| | 30 | 45 | 60 | 90 | 120 | 150 |
| 800820 | 2.1 | 1.9 | 2.9 | 2.1 | 1.3 | 2.3 |
| 800814 | 2.1 | 2.0 | 3.7 | ---- | ---- | ---- |
| 800829 | 1.9 | 1.9 | 2.4 | 2.4 | 2.4 | 2.5 |
| 800911 | ---- | 3.4 | ---- | 3.1 | ---- | ---- |
| 800917 | ---- | ---- | ---- | ---- | ---- | ---- |
| 800926 | 2.4 | ---- | 3.6 | 2.1 | ---- | ---- |
| 801003 | ---- | 2.6 | ---- | 2.6 | 2.5 | 1.7 |
| 801008 | 2.3 | 2.4 | 3.5 | ---- | 2.9 | 2.5 |
| 801023 | 2.3 | 2.4 | 3.6 | ---- | 3.0 | 2.5 |
| 801104 | 2.5 | ---- | 3.7 | ---- | 2.9 | ---- |

CONDUCTIVITY -mS/cm-

PLOT 35G 1980

| DATE | DEPTH (cm) | | | | | |
|--------|------------|------|------|------|------|------|
| | 30 | 45 | 60 | 90 | 120 | 150 |
| 800820 | 2.1 | ---- | 3.4 | 2.5 | ---- | 2.3 |
| 800814 | ---- | ---- | ---- | ---- | ---- | ---- |
| 800829 | 1.9 | ---- | 3.5 | 2.4 | 2.5 | 2.0 |
| 800911 | ---- | ---- | 3.7 | 2.0 | 2.5 | 2.2 |
| 800917 | ---- | ---- | ---- | 2.6 | 2.6 | ---- |
| 800926 | 3.5 | 3.1 | 3.9 | 2.0 | ---- | ---- |
| 801003 | ---- | ---- | 4.4 | 1.9 | 2.3 | 2.1 |
| 801008 | 2.3 | ---- | 4.5 | 2.2 | ---- | 2.1 |
| 801023 | 3.1 | 3.4 | 4.8 | 2.2 | 2.5 | 2.2 |
| 801104 | ---- | 3.5 | ---- | 2.5 | 2.6 | 2.2 |

SOIL EXTRACT ANALYSIS 1980-1982

CONDUCTIVITY -mS/cm-

PLOT 35 1980

| DATE | DEPTH (cm) | | | | | |
|--------|------------|------|------|------|------|------|
| | 30 | 45 | 60 | 90 | 120 | 150 |
| 800820 | 2.8 | 3.5 | 3.1 | ---- | ---- | ---- |
| 800814 | ---- | ---- | ---- | ---- | ---- | ---- |
| 800829 | 2.5 | 2.9 | 2.3 | ---- | ---- | ---- |
| 800911 | ---- | ---- | 3.9 | ---- | ---- | ---- |
| 800917 | ---- | ---- | ---- | ---- | ---- | ---- |
| 800926 | ---- | ---- | ---- | 1.9 | 2.4 | ---- |
| 801003 | 3.4 | ---- | ---- | 2.5 | 2.2 | ---- |
| 801008 | 5.4 | 3.6 | 3.1 | 2.5 | 2.7 | ---- |
| 801023 | 3.5 | ---- | 3.5 | 1.7 | 2.5 | ---- |
| 801104 | 4.8 | ---- | 3.5 | ---- | ---- | ---- |

CONDUCTIVITY -mS/cm-

PLOT 20 1980

| DATE | DEPTH (cm) | | | | | |
|--------|------------|------|------|------|------|------|
| | 30 | 45 | 60 | 90 | 120 | 150 |
| 800820 | ---- | ---- | ---- | ---- | ---- | ---- |
| 800814 | ---- | ---- | ---- | ---- | ---- | ---- |
| 800829 | ---- | 3.1 | 3.4 | ---- | ---- | ---- |
| 800911 | ---- | ---- | 7.0 | ---- | 5.2 | ---- |
| 800917 | ---- | ---- | ---- | ---- | ---- | ---- |
| 800926 | ---- | ---- | ---- | ---- | ---- | 7.7 |
| 801003 | ---- | ---- | ---- | ---- | ---- | 3.3 |
| 801008 | ---- | ---- | ---- | ---- | ---- | 9.5 |
| 801023 | ---- | ---- | ---- | 1.6 | ---- | 9.8 |
| 801104 | ---- | ---- | 4.9 | 2.2 | ---- | 9.5 |

Appendix B. Laboratory-determined parameters of field soil water
extracts 1981.

Sodium
Chloride
Bicarbonate
Electrical Conductivity
Nitrate
pH
Total Phosphate
Ammonia

SOIL EXTRACT ANALYSIS 1980-1982

SODIUM (Na) -ppm-

PLOT 50A 1981

| DATE | DEPTH (cm) | | | | | |
|--------|------------|------|-------|-------|-------|--------|
| | 30 | 45 | 60 | 90 | 120 | 150 |
| 810615 | ---- | ---- | ---- | ---- | ---- | 72.00 |
| 810622 | ---- | ---- | ---- | ---- | ---- | 82.00 |
| 810629 | ---- | ---- | ---- | ---- | ---- | 86.00 |
| 810708 | ---- | ---- | ---- | ---- | ---- | 72.00 |
| 810715 | ---- | ---- | ---- | ---- | ---- | 115.00 |
| 810722 | ---- | ---- | ---- | ---- | ---- | 121.00 |
| 810728 | ---- | ---- | ---- | ---- | ---- | 106.00 |
| 810805 | ---- | ---- | ---- | 660.0 | 110.0 | 105.00 |
| 810812 | ---- | ---- | ---- | 540.0 | 106.0 | 113.00 |
| 810819 | 470.0 | ---- | 550.0 | 540.0 | 140.0 | 113.00 |
| 810827 | 590.0 | ---- | 640.0 | 840.0 | 177.0 | 150.00 |
| 810904 | 920.0 | ---- | 600.0 | 650.0 | 176.0 | 105.00 |
| 810929 | ---- | ---- | ---- | ---- | 250.0 | 92.00 |
| 811007 | 570.0 | ---- | ---- | 690.0 | 232.0 | 96.00 |
| 811015 | ---- | ---- | ---- | 360.0 | 190.0 | 88.00 |

SODIUM (Na) -ppm-

PLOT 50 1981

| DATE | DEPTH (cm) | | | | | |
|--------|------------|-------|-------|-------|-------|--------|
| | 30 | 45 | 60 | 90 | 120 | 150 |
| 810615 | 373.0 | 312.0 | 452.0 | 183.0 | 51.0 | 66.00 |
| 810622 | 630.0 | 394.0 | ---- | 220.0 | 109.0 | 262.00 |
| 810629 | ---- | 540.0 | 468.0 | 293.0 | 95.0 | 234.00 |
| 810708 | 531.0 | 480.0 | ---- | 342.0 | 90.0 | 180.00 |
| 810715 | ---- | 460.0 | ---- | 430.0 | 71.0 | 158.00 |
| 810722 | 570.0 | 590.0 | 580.0 | 382.0 | 76.0 | 170.00 |
| 810728 | 650.0 | 650.0 | ---- | 470.0 | 149.0 | 213.00 |
| 810805 | 445.0 | ---- | ---- | 510.0 | 193.0 | 220.00 |
| 810812 | 366.0 | 610.0 | ---- | 427.0 | 186.0 | 251.00 |
| 810819 | 310.0 | 429.0 | ---- | 450.0 | 151.0 | 218.00 |
| 810827 | 317.0 | 570.0 | ---- | ---- | 149.0 | 235.00 |
| 810904 | 388.0 | 520.0 | ---- | ---- | 124.0 | 244.00 |
| 810929 | 530.0 | ---- | ---- | ---- | ---- | ---- |
| 811007 | 450.0 | ---- | ---- | 530.0 | ---- | ---- |
| 811015 | 540.0 | 670.0 | ---- | ---- | 340.0 | ---- |

SOIL EXTRACT ANALYSIS 1980-1982

SODIUM (Na) -ppm-

PLOT 35G 1981

| DATE | DEPTH (cm) | | | | | |
|--------|------------|-------|--------|-------|-------|-------|
| | 30 | 45 | 60 | 90 | 120 | 150 |
| 810615 | ---- | 345.0 | ---- | 62.0 | 25.0 | ---- |
| 810622 | ---- | 560.0 | ---- | 76.0 | 39.0 | 61.00 |
| 810629 | ---- | 435.0 | ---- | 109.0 | 46.0 | ---- |
| 810708 | ---- | 490.0 | 1480.0 | 106.0 | 40.0 | ---- |
| 810715 | 740.0 | 540.0 | 900.0 | 153.0 | 62.0 | ---- |
| 810722 | ---- | 740.0 | 1090.0 | ---- | 65.0 | 52.00 |
| 810728 | 560.0 | 780.0 | 1030.0 | 90.0 | 60.0 | 77.00 |
| 810805 | 340.0 | 335.0 | 610.0 | 223.0 | 106.0 | 54.00 |
| 810812 | ---- | ---- | 730.0 | 293.0 | 106.0 | 68.00 |
| 810819 | ---- | 365.0 | 720.0 | 336.0 | 102.0 | 78.00 |
| 810827 | 490.0 | 530.0 | 600.0 | 520.0 | 143.0 | 71.00 |
| 810904 | 380.0 | 420.0 | 540.0 | 380.0 | 126.0 | 70.00 |
| 810929 | ---- | ---- | ---- | ---- | 120.0 | 86.00 |
| 811007 | ---- | 500.0 | 820.0 | 580.0 | 148.0 | ---- |
| 811015 | ---- | 530.0 | 580.0 | 450.0 | 170.0 | 80.00 |

SODIUM (Na) -ppm-

PLOT 35 1981

| DATE | DEPTH (cm) | | | | | |
|--------|------------|-------|-------|------|------|------|
| | 30 | 45 | 60 | 90 | 120 | 150 |
| 810615 | ---- | 740.0 | 372.0 | ---- | ---- | ---- |
| 810622 | ---- | 750.0 | 414.0 | ---- | ---- | ---- |
| 810629 | 520.0 | 670.0 | 560.0 | ---- | ---- | ---- |
| 810708 | ---- | 780.0 | ---- | ---- | ---- | ---- |
| 810715 | ---- | 540.0 | ---- | ---- | ---- | ---- |
| 810722 | ---- | ---- | ---- | ---- | ---- | ---- |
| 810728 | 700.0 | 730.0 | 650.0 | ---- | ---- | ---- |
| 810805 | ---- | 467.0 | 470.0 | ---- | ---- | ---- |
| 810812 | ---- | ---- | ---- | ---- | ---- | ---- |
| 810819 | 760.0 | 640.0 | 770.0 | ---- | ---- | ---- |
| 810827 | ---- | 870.0 | 920.0 | ---- | ---- | ---- |
| 810904 | 750.0 | 670.0 | 780.0 | ---- | ---- | ---- |
| 810929 | ---- | ---- | ---- | ---- | ---- | ---- |
| 811007 | ---- | ---- | ---- | ---- | ---- | ---- |
| 811015 | ---- | ---- | ---- | ---- | ---- | ---- |

SOIL EXTRACT ANALYSIS 1980-1982

CHLORIDE (Cl) -ppm- PLOT 50A 1981

| DATE | DEPTH (cm) | | | | | |
|--------|------------|------|-------|--------|-------|--------|
| | 30 | 45 | 60 | 90 | 120 | 150 |
| 810615 | ---- | ---- | ---- | ---- | ---- | 625.00 |
| 810622 | ---- | ---- | ---- | ---- | ---- | 660.00 |
| 810629 | ---- | ---- | ---- | ---- | ---- | 575.00 |
| 810708 | ---- | ---- | ---- | ---- | ---- | 610.00 |
| 810715 | ---- | ---- | ---- | ---- | ---- | 630.00 |
| 810722 | ---- | ---- | ---- | ---- | ---- | 610.00 |
| 810728 | ---- | ---- | ---- | ---- | ---- | 555.00 |
| 810805 | ---- | ---- | ---- | 940.0 | 310.0 | 570.00 |
| 810812 | ---- | ---- | ---- | 930.0 | 840.0 | 570.00 |
| 810819 | 520.0 | ---- | 910.0 | 925.0 | 840.0 | 550.00 |
| 810827 | 525.0 | ---- | 800.0 | 940.0 | 370.0 | 560.00 |
| 810904 | 505.0 | ---- | 580.0 | 740.0 | 860.0 | 530.00 |
| 810929 | ---- | ---- | ---- | ---- | ---- | ---- |
| 811007 | 790.0 | ---- | ---- | 1070.0 | 360.0 | 460.00 |
| 811015 | ---- | ---- | ---- | 1212.0 | 940.0 | 490.00 |

CHLORIDE (Cl) -ppm- PLOT 50 1981

| DATE | DEPTH (cm) | | | | | |
|--------|------------|-------|--------|--------|-------|--------|
| | 30 | 45 | 60 | 90 | 120 | 150 |
| 810615 | 500.0 | 515.0 | 496.0 | 635.0 | 635.0 | 655.00 |
| 810622 | 610.0 | 707.0 | ---- | 700.0 | 690.0 | 770.00 |
| 810629 | ---- | 750.0 | 562.0 | 745.0 | 720.0 | 770.00 |
| 810708 | 530.0 | 710.0 | ---- | 840.0 | 830.0 | 330.00 |
| 810715 | ---- | 710.0 | ---- | 910.0 | 820.0 | 830.00 |
| 810722 | 500.0 | 700.0 | 1000.0 | 950.0 | 790.0 | 370.00 |
| 810728 | 740.0 | 900.0 | ---- | 965.0 | 718.0 | 940.00 |
| 810805 | 550.0 | ---- | ---- | 970.0 | 770.0 | 950.00 |
| 810812 | 295.0 | 590.0 | ---- | 1030.0 | 730.0 | 810.00 |
| 810819 | 240.0 | 395.0 | ---- | 1035.0 | 760.0 | 915.00 |
| 810827 | 245.0 | 410.0 | ---- | ---- | 770.0 | 820.00 |
| 810904 | 480.0 | 660.0 | ---- | ---- | 790.0 | 690.00 |
| 810929 | ---- | ---- | ---- | ---- | ---- | ---- |
| 811007 | 715.0 | ---- | ---- | 1115.0 | ---- | ---- |
| 811015 | 740.0 | 990.0 | ---- | ---- | 780.0 | ---- |

SOIL EXTRACT ANALYSIS 1980-1982

| DATE | CHLORIDE (Cl) -ppm- | | | | | | PLOT 35G 1981 | | | | | |
|--------|---------------------|--------|------------|--------|------------|---------|---------------|--|------------|--|------------|--|
| | DEPTH (cm) | | DEPTH (cm) | | DEPTH (cm) | | DEPTH (cm) | | DEPTH (cm) | | DEPTH (cm) | |
| | 30 | 45 | 60 | 90 | 120 | 150 | | | | | | |
| 810615 | ---- | 502.0 | ---- | 300.0 | 705.0 | ---- | | | | | | |
| 810622 | ---- | 790.0 | ---- | 390.0 | 860.0 | 600.00 | | | | | | |
| 810629 | ---- | 1000.0 | ---- | 970.0 | 1040.0 | ---- | | | | | | |
| 810708 | ---- | 1130.0 | 1680.0 | 1060.0 | 1170.0 | ---- | | | | | | |
| 810715 | 800.0 | 880.0 | 1145.0 | 1120.0 | 1450.0 | ---- | | | | | | |
| 810722 | ---- | 1130.0 | 1310.0 | ---- | 1590.0 | 750.00 | | | | | | |
| 810728 | 625.0 | 1030.0 | 1100.0 | 900.0 | 1715.0 | 780.00 | | | | | | |
| 810805 | 415.0 | 550.0 | 780.0 | 1012.0 | 1680.0 | 890.00 | | | | | | |
| 810812 | ---- | ---- | 880.0 | 880.0 | 1690.0 | 950.00 | | | | | | |
| 810819 | ---- | 450.0 | 830.0 | 1170.0 | 1650.0 | 930.00 | | | | | | |
| 810827 | 465.0 | 555.0 | 680.0 | 920.0 | 1670.0 | 955.00 | | | | | | |
| 810904 | 450.0 | 455.0 | 548.0 | 762.0 | 1640.0 | 1050.00 | | | | | | |
| 810929 | ---- | ---- | ---- | ---- | ---- | ---- | | | | | | |
| 811007 | ---- | 585.0 | 640.0 | 970.0 | 1650.0 | ---- | | | | | | |
| 811015 | ---- | 750.0 | 770.0 | 1010.0 | 1630.0 | 1100.00 | | | | | | |

| DATE | CHLORIDE (Cl) -ppm- | | | | | | PLOT 35 1981 | | | | | |
|--------|---------------------|--------|------------|------|------------|------|--------------|--|------------|--|------------|--|
| | DEPTH (cm) | | DEPTH (cm) | | DEPTH (cm) | | DEPTH (cm) | | DEPTH (cm) | | DEPTH (cm) | |
| | 30 | 45 | 60 | 90 | 120 | 150 | | | | | | |
| 810615 | ---- | 805.0 | 690.0 | ---- | ---- | ---- | | | | | | |
| 810622 | ---- | 935.0 | 805.0 | ---- | ---- | ---- | | | | | | |
| 810629 | 700.0 | 1090.0 | 965.0 | ---- | ---- | ---- | | | | | | |
| 810708 | ---- | 1020.0 | ---- | ---- | ---- | ---- | | | | | | |
| 810715 | ---- | 675.0 | ---- | ---- | ---- | ---- | | | | | | |
| 810722 | ---- | ---- | ---- | ---- | ---- | ---- | | | | | | |
| 810728 | 100.0 | 765.0 | 1100.0 | ---- | ---- | ---- | | | | | | |
| 810805 | ---- | 880.0 | 1220.0 | ---- | ---- | ---- | | | | | | |
| 810812 | ---- | ---- | ---- | ---- | ---- | ---- | | | | | | |
| 810819 | 930.0 | 865.0 | 1020.0 | ---- | ---- | ---- | | | | | | |
| 810827 | ---- | 780.0 | 1080.0 | ---- | ---- | ---- | | | | | | |
| 810904 | 800.0 | 640.0 | 990.0 | ---- | ---- | ---- | | | | | | |
| 810929 | ---- | ---- | ---- | ---- | ---- | ---- | | | | | | |
| 811007 | ---- | ---- | ---- | ---- | ---- | ---- | | | | | | |
| 811015 | ---- | ---- | ---- | ---- | ---- | ---- | | | | | | |

SOIL EXTRACT ANALYSIS 1980-1982

| BICARBONATE (HCO ₃) -ppm- | | PLOT 50A 1981 | | | | |
|---------------------------------------|------------|---------------|-------|-------|-------|--------|
| DATE | DEPTH (cm) | | | | | |
| | 30 | 45 | 60 | 90 | 120 | 150 |
| 810615 | ---- | ---- | ---- | ---- | ---- | 800.00 |
| 810622 | ---- | ---- | ---- | ---- | ---- | 112.00 |
| 810629 | ---- | ---- | ---- | ---- | ---- | 910.00 |
| 810708 | ---- | ---- | ---- | ---- | ---- | 659.00 |
| 810715 | ---- | ---- | ---- | ---- | ---- | 391.00 |
| 810722 | ---- | ---- | ---- | ---- | ---- | 708.00 |
| 810728 | ---- | ---- | ---- | ---- | ---- | 921.00 |
| 810805 | ---- | ---- | ---- | 610.0 | 725.0 | 927.00 |
| 810812 | ---- | ---- | ---- | 494.0 | 396.0 | 952.00 |
| 810819 | 317.0 | ---- | 354.0 | 559.0 | 610.0 | 975.00 |
| 810827 | 231.0 | ---- | 171.0 | 659.0 | 647.0 | ---- |
| 810904 | 122.0 | ---- | 146.0 | 671.0 | 494.0 | 330.00 |
| 810929 | ---- | ---- | ---- | ---- | 379.0 | 932.00 |
| 811007 | 214.0 | ---- | ---- | 537.0 | 671.0 | 775.00 |
| 811015 | ---- | ---- | ---- | 360.0 | 403.0 | 586.00 |

| BICARBONATE (HCO ₃) -ppm- | | PLOT 50 1981 | | | | |
|---------------------------------------|------------|--------------|-------|-------|-------|--------|
| DATE | DEPTH (cm) | | | | | |
| | 30 | 45 | 60 | 90 | 120 | 150 |
| 810615 | 244.0 | 190.0 | 229.0 | 512.0 | 566.0 | 664.00 |
| 810622 | 234.0 | 176.0 | ---- | 537.0 | 571.0 | 664.00 |
| 810629 | ---- | 127.0 | 190.0 | 517.0 | 576.0 | 678.00 |
| 810708 | 146.0 | 232.0 | ---- | 366.0 | 451.0 | 537.00 |
| 810715 | ---- | 146.0 | ---- | 427.0 | 537.0 | 586.00 |
| 810722 | 195.0 | 146.0 | 146.0 | 464.0 | 438.0 | 390.00 |
| 810728 | 183.0 | 165.0 | ---- | 427.0 | 525.0 | 708.00 |
| 810805 | 189.0 | ---- | ---- | 231.0 | 438.0 | 725.00 |
| 810812 | 207.0 | 116.0 | ---- | 451.0 | 354.0 | 665.00 |
| 810819 | 232.0 | 214.0 | ---- | 476.0 | 360.0 | 769.00 |
| 810827 | 281.0 | 146.0 | ---- | ---- | 256.0 | 695.00 |
| 810904 | 165.0 | 159.0 | ---- | ---- | 183.0 | 671.00 |
| 810929 | 159.0 | ---- | ---- | ---- | ---- | ---- |
| 811007 | 232.0 | ---- | ---- | 134.0 | ---- | ---- |
| 811015 | 195.0 | 122.0 | ---- | ---- | 214.0 | ---- |

SOIL EXTRACT ANALYSIS 1980-1982

| BICARBONATE (HCO ₃) -ppm- | | PLOT 35G 1981 | | | | |
|---------------------------------------|------------|---------------|-------|-------|-------|--------|
| DATE | DEPTH (cm) | | | | | |
| | 30 | 45 | 60 | 90 | 120 | 150 |
| 810615 | ---- | 300.0 | ---- | 649.0 | 771.0 | ---- |
| 810622 | ---- | 293.0 | ---- | 822.0 | 839.0 | 717.0 |
| 810629 | ---- | 238.0 | ---- | 917.0 | 985.0 | ---- |
| 810708 | ---- | 220.0 | 354.0 | 952.0 | 927.0 | ---- |
| 810715 | 220.0 | 451.0 | 439.0 | 927.0 | 927.0 | ---- |
| 810722 | ---- | 329.0 | 299.0 | ---- | 854.0 | 927.0 |
| 810728 | 232.0 | 366.0 | 427.0 | 427.0 | 595.0 | 1013.0 |
| 810805 | 231.0 | 598.0 | 476.0 | 350.0 | 366.0 | 1051.0 |
| 810812 | ---- | ---- | 244.0 | 703.0 | 366.0 | 1037.0 |
| 810819 | ---- | 439.0 | 403.0 | 805.0 | 610.0 | 1013.0 |
| 810827 | 220.0 | 354.0 | 403.0 | 595.0 | 708.0 | 1000.0 |
| 810904 | 269.0 | 342.0 | 415.0 | 522.0 | 573.0 | 988.0 |
| 810929 | ---- | ---- | ---- | ---- | 622.0 | 847.0 |
| 811007 | ---- | 220.0 | 232.0 | 732.0 | 610.0 | ---- |
| 811015 | ---- | 183.0 | 366.0 | 708.0 | 366.0 | 1025.0 |

| BICARBONATE (HCO ₃) -ppm- | | PLOT 35 1981 | | | | |
|---------------------------------------|------------|--------------|-------|------|------|------|
| DATE | DEPTH (cm) | | | | | |
| | 30 | 45 | 60 | 90 | 120 | 150 |
| 810615 | ---- | 368.0 | 283.0 | ---- | ---- | ---- |
| 810622 | ---- | 337.0 | 251.0 | ---- | ---- | ---- |
| 810629 | 185.0 | 342.0 | 264.0 | ---- | ---- | ---- |
| 810708 | ---- | 171.0 | ---- | ---- | ---- | ---- |
| 810715 | ---- | 317.0 | ---- | ---- | ---- | ---- |
| 810722 | ---- | ---- | ---- | ---- | ---- | ---- |
| 810728 | 116.0 | 482.0 | 171.0 | ---- | ---- | ---- |
| 810805 | ---- | 354.0 | 263.0 | ---- | ---- | ---- |
| 810812 | ---- | ---- | ---- | ---- | ---- | ---- |
| 810819 | 171.0 | 366.0 | 195.0 | ---- | ---- | ---- |
| 810827 | ---- | 342.0 | 244.0 | ---- | ---- | ---- |
| 810904 | 153.0 | 195.0 | 153.0 | ---- | ---- | ---- |
| 810929 | ---- | ---- | ---- | ---- | ---- | ---- |
| 811007 | ---- | ---- | ---- | ---- | ---- | ---- |
| 811015 | ---- | ---- | ---- | ---- | ---- | ---- |

SOIL EXTRACT ANALYSIS 1980-1982

| DATE | CONDUCTIVITY -mS/cm- | | | | | 150 |
|--------|----------------------|------|------------|------|------|------|
| | 30 | 45 | DEPTH (cm) | | | |
| | | | 60 | 90 | 120 | |
| 810615 | ---- | ---- | ---- | ---- | ---- | 3.2 |
| 810622 | ---- | ---- | ---- | ---- | ---- | 3.3 |
| 810629 | ---- | ---- | ---- | ---- | ---- | 3.2 |
| 810708 | ---- | ---- | ---- | ---- | ---- | 3.3 |
| 810715 | ---- | ---- | ---- | ---- | ---- | 3.5 |
| 810722 | ---- | ---- | ---- | ---- | ---- | 3.2 |
| 810728 | ---- | ---- | ---- | ---- | ---- | 4.1 |
| 810805 | ---- | ---- | ---- | 5.3 | 4.5 | 3.6 |
| 810812 | ---- | ---- | ---- | 5.5 | 4.3 | 3.7 |
| 810819 | 3.2 | ---- | 5.3 | 5.6 | 4.6 | 3.7 |
| 810827 | 3.2 | ---- | 4.0 | 5.8 | 4.3 | ---- |
| 810904 | 2.8 | ---- | 3.7 | 5.1 | 4.5 | 3.6 |
| 810929 | ---- | ---- | ---- | ---- | 4.7 | 3.3 |
| 811007 | 4.2 | ---- | ---- | 5.7 | 4.5 | 3.3 |
| 811015 | ---- | ---- | ---- | 5.9 | 4.6 | 3.4 |

| DATE | CONDUCTIVITY -mS/cm- | | | | | 150 |
|--------|----------------------|------|------------|------|------|------|
| | 30 | 45 | DEPTH (cm) | | | |
| | | | 60 | 90 | 120 | |
| 810615 | 2.8 | 2.6 | 3.4 | 3.3 | 3.1 | 3.2 |
| 810622 | 2.8 | 3.4 | ---- | 3.5 | 3.4 | 3.6 |
| 810629 | ---- | 3.6 | 3.0 | 3.6 | 3.5 | 3.6 |
| 810708 | 3.1 | 3.7 | ---- | 4.3 | 3.9 | 3.9 |
| 810715 | ---- | 3.7 | ---- | 4.5 | 3.8 | 3.9 |
| 810722 | 3.3 | 3.7 | 3.8 | 4.8 | 3.6 | 3.3 |
| 810728 | 4.1 | 4.5 | ---- | 5.9 | 4.0 | 5.3 |
| 810805 | 3.3 | ---- | ---- | 4.7 | 3.7 | 4.5 |
| 810812 | 2.2 | 4.1 | ---- | 5.7 | 3.8 | 4.4 |
| 810819 | ---- | 3.0 | ---- | 7.0 | 3.6 | 4.5 |
| 810827 | 2.0 | 2.6 | ---- | ---- | 3.9 | 4.4 |
| 810904 | 3.3 | 3.6 | ---- | ---- | 3.7 | 4.1 |
| 810929 | 3.2 | ---- | ---- | ---- | ---- | ---- |
| 811007 | 3.5 | ---- | ---- | 5.5 | ---- | ---- |
| 811015 | 3.7 | 4.5 | ---- | 2.5 | 2.6 | ---- |

SOIL EXTRACT ANALYSIS 1980-1982

NITRATE (as N) -ppm-

PLOT 50A 1981

| DATE | DEPTH (cm) | | | | | |
|--------|------------|------|------|------|------|------|
| | 30 | 45 | 60 | 90 | 120 | 150 |
| 810615 | ---- | ---- | ---- | ---- | ---- | 1.25 |
| 810622 | ---- | ---- | ---- | ---- | ---- | 1.09 |
| 810629 | ---- | ---- | ---- | ---- | ---- | 1.55 |
| 810708 | ---- | ---- | ---- | ---- | ---- | 3.52 |
| 810715 | ---- | ---- | ---- | ---- | ---- | 1.06 |
| 810722 | ---- | ---- | ---- | ---- | ---- | 0.91 |
| 810728 | ---- | ---- | ---- | ---- | ---- | 1.14 |
| 810805 | ---- | ---- | ---- | 0.34 | 0.06 | 0.59 |
| 810812 | ---- | ---- | ---- | 0.14 | 0.04 | 0.65 |
| 810819 | 4.40 | ---- | 2.70 | 0.06 | 0.04 | 0.41 |
| 810827 | 0.10 | ---- | 2.33 | 0.04 | 0.02 | 0.45 |
| 810904 | 0.09 | ---- | 2.85 | 0.77 | 0.02 | 0.79 |
| 810929 | ---- | ---- | ---- | ---- | 0.03 | 0.12 |
| 811007 | 3.12 | ---- | ---- | 0.06 | 0.05 | 0.63 |
| 811015 | ---- | ---- | ---- | 0.02 | ---- | 0.53 |

NITRATE (as N) -ppm-

PLOT 50 1981

| DATE | DEPTH (cm) | | | | | |
|--------|------------|--------|-------|-------|------|------|
| | 30 | 45 | 60 | 90 | 120 | 150 |
| 810615 | 1.53 | 11.38 | 0.67 | 0.04 | 0.16 | ---- |
| 810622 | 23.50 | 63.00 | ---- | 0.04 | 0.06 | 0.02 |
| 810629 | ---- | 147.50 | 51.50 | 1.32 | 0.07 | 0.04 |
| 810708 | 64.00 | 53.75 | ---- | 24.75 | 0.26 | 0.04 |
| 810715 | ---- | 20.50 | ---- | 43.00 | 0.06 | 0.02 |
| 810722 | 47.00 | 24.75 | 5.20 | 22.00 | 0.13 | 0.10 |
| 810728 | 32.00 | 23.00 | ---- | 20.25 | 0.10 | 0.06 |
| 810805 | 10.00 | ---- | ---- | 23.25 | 0.57 | 0.04 |
| 810812 | 6.50 | 3.90 | ---- | 22.75 | 0.35 | 0.06 |
| 810819 | 6.63 | 0.94 | ---- | 11.12 | 0.42 | 0.04 |
| 810827 | 3.75 | 3.02 | ---- | ---- | 0.14 | 0.06 |
| 810904 | 7.12 | 2.34 | ---- | ---- | 0.07 | 0.04 |
| 810929 | 6.25 | ---- | ---- | ---- | ---- | ---- |
| 811007 | 2.72 | ---- | ---- | 0.08 | ---- | ---- |
| 811015 | 2.42 | 3.30 | ---- | ---- | 0.12 | ---- |

SOIL EXTRACT ANALYSIS 1980-1982

| DATE | NITRATE (as N) -ppm- | | | | | |
|--------|----------------------|-------|-------|------|------|------|
| | PLOT 35G 1981 | | | | | |
| | DEPTH (cm) | | | | | |
| | 30 | 45 | 60 | 90 | 120 | 150 |
| 810615 | ---- | 0.14 | ---- | 0.04 | 0.03 | ---- |
| 810622 | ---- | 0.09 | ---- | 0.05 | 0.05 | 2.05 |
| 810629 | ---- | 0.17 | ---- | 0.02 | 0.02 | ---- |
| 810703 | ---- | 1.50 | 0.60 | 0.05 | 0.03 | ---- |
| 810715 | 10.52 | 13.75 | 10.75 | 0.05 | 0.06 | ---- |
| 810722 | ---- | 3.75 | 5.35 | ---- | 0.04 | 0.45 |
| 810723 | 16.50 | 5.00 | 5.00 | 0.14 | 0.05 | 0.26 |
| 810805 | 9.75 | 2.60 | 3.50 | 0.49 | 0.04 | 0.19 |
| 810812 | ---- | ---- | 1.30 | 0.86 | 0.05 | 0.27 |
| 810819 | ---- | 3.70 | 2.65 | 0.05 | 0.06 | 0.13 |
| 810827 | 1.33 | 2.30 | 6.70 | 0.10 | 0.02 | 0.13 |
| 810904 | 3.70 | 4.35 | 10.12 | 0.04 | 0.04 | 0.06 |
| 810929 | ---- | ---- | ---- | ---- | 0.05 | 0.22 |
| 811007 | ---- | 2.50 | 3.75 | 0.15 | 0.03 | ---- |
| 811015 | ---- | 2.42 | 5.30 | 0.05 | 0.04 | 0.03 |

| DATE | NITRATE (as N) -ppm- | | | | | |
|--------|----------------------|-------|-------|------|------|------|
| | PLOT 35 1981 | | | | | |
| | DEPTH (cm) | | | | | |
| | 30 | 45 | 60 | 90 | 120 | 150 |
| 810615 | ---- | 0.04 | 0.10 | ---- | ---- | ---- |
| 810622 | ---- | 0.03 | 0.12 | ---- | ---- | ---- |
| 810629 | 1.80 | 0.32 | 2.00 | ---- | ---- | ---- |
| 810703 | ---- | 3.50 | ---- | ---- | ---- | ---- |
| 810715 | ---- | 15.38 | ---- | ---- | ---- | ---- |
| 810722 | ---- | ---- | ---- | ---- | ---- | ---- |
| 810723 | 11.50 | 26.50 | 0.60 | ---- | ---- | ---- |
| 810805 | ---- | 5.40 | 10.50 | ---- | ---- | ---- |
| 810812 | ---- | ---- | ---- | ---- | ---- | ---- |
| 810819 | 16.25 | 6.50 | 5.52 | ---- | ---- | ---- |
| 810827 | ---- | 14.25 | 4.55 | ---- | ---- | ---- |
| 810904 | 2.34 | 11.50 | 3.00 | ---- | ---- | ---- |
| 810929 | ---- | ---- | ---- | ---- | ---- | ---- |
| 811007 | ---- | ---- | ---- | ---- | ---- | ---- |
| 811015 | ---- | ---- | ---- | ---- | ---- | ---- |

SOIL EXTRACT ANALYSIS 1980-1982

| DATE | PH | | PLOT 50A 1981 | | | |
|--------|------------|------|---------------|------|------|------|
| | DEPTH (cm) | | | | | |
| | 30 | 45 | 60 | 90 | 120' | 150 |
| 810615 | ---- | ---- | ---- | ---- | ---- | 8.00 |
| 810622 | ---- | ---- | ---- | ---- | ---- | 7.90 |
| 810629 | ---- | ---- | ---- | ---- | ---- | 7.50 |
| 810708 | ---- | ---- | ---- | ---- | ---- | 8.08 |
| 810715 | ---- | ---- | ---- | ---- | ---- | 7.25 |
| 810722 | ---- | ---- | ---- | ---- | ---- | 8.05 |
| 810728 | ---- | ---- | ---- | ---- | ---- | 8.00 |
| 810805 | ---- | ---- | ---- | 7.48 | 8.21 | 7.70 |
| 810812 | ---- | ---- | ---- | 7.82 | 8.18 | 7.65 |
| 810819 | 8.29 | ---- | 7.75 | 7.15 | 7.73 | 7.45 |
| 810827 | 8.13 | ---- | 7.99 | 7.45 | 7.56 | 7.50 |
| 810904 | 7.80 | ---- | 8.20 | 7.41 | 7.99 | 8.00 |
| 810929 | ---- | ---- | ---- | ---- | 7.60 | 8.23 |
| 811007 | 8.22 | ---- | ---- | 7.82 | 7.89 | 8.40 |
| 811015 | ---- | ---- | ---- | 7.88 | 8.19 | 8.88 |

| DATE | PH | | PLOT 50 1981 | | | |
|--------|------------|------|--------------|------|------|------|
| | DEPTH (cm) | | | | | |
| | 30 | 45 | 60 | 90 | 120 | 150 |
| 810615 | 8.31 | 8.10 | 7.91 | 7.80 | 7.30 | 7.35 |
| 810622 | 8.28 | 8.00 | ---- | 7.30 | 7.28 | 7.40 |
| 810629 | ---- | 8.01 | 8.23 | 7.05 | 7.21 | 7.20 |
| 810708 | 8.48 | 8.15 | ---- | 7.58 | 7.77 | 7.60 |
| 810715 | ---- | 7.95 | ---- | 7.20 | 7.62 | 7.51 |
| 810722 | 8.28 | 8.13 | 8.42 | 7.32 | 7.68 | 7.89 |
| 810728 | 8.30 | 8.15 | ---- | 7.49 | 7.70 | 7.58 |
| 810805 | 8.40 | ---- | ---- | 7.81 | 7.81 | 7.37 |
| 810812 | 8.50 | 8.30 | ---- | 7.61 | 7.91 | 7.70 |
| 810819 | 8.42 | 8.22 | ---- | 7.49 | 8.10 | 7.35 |
| 810827 | 8.25 | 8.23 | ---- | ---- | 7.38 | 7.48 |
| 810904 | 8.22 | 8.45 | ---- | ---- | 8.22 | 8.08 |
| 810929 | 8.51 | ---- | ---- | ---- | ---- | ---- |
| 811007 | 8.32 | ---- | ---- | 8.10 | ---- | ---- |
| 811015 | 8.35 | 8.09 | ---- | ---- | 8.50 | ---- |

SOIL EXTRACT ANALYSIS 1980-1982

T-PO4-P (HCO3) -mg-

PLOT 50A 1981

| DATE | DEPTH (cm) | | | | | |
|--------|------------|------|------|------|------|------|
| | 30 | 45 | 60 | 90 | 120 | 150 |
| 810615 | ---- | ---- | ---- | ---- | ---- | 0.03 |
| 810622 | ---- | ---- | ---- | ---- | ---- | 0.02 |
| 810629 | ---- | ---- | ---- | ---- | ---- | 0.02 |
| 810708 | ---- | ---- | ---- | ---- | ---- | 0.05 |
| 810715 | ---- | ---- | ---- | ---- | ---- | 0.02 |
| 810722 | ---- | ---- | ---- | ---- | ---- | 0.01 |
| 810728 | ---- | ---- | ---- | ---- | ---- | 0.05 |
| 810805 | ---- | ---- | ---- | 0.15 | 0.25 | 0.01 |
| 810812 | ---- | ---- | ---- | 0.01 | 0.01 | ---- |
| 810819 | ---- | ---- | ---- | ---- | 0.01 | ---- |
| 810827 | 0.15 | ---- | ---- | ---- | ---- | ---- |
| 810904 | 0.05 | ---- | ---- | ---- | ---- | ---- |
| 810929 | ---- | ---- | ---- | ---- | ---- | ---- |
| 811007 | ---- | ---- | ---- | 0.01 | ---- | ---- |
| 811015 | ---- | ---- | ---- | ---- | ---- | ---- |

T-PO4 as P -ppm-

PLOT 50 1981

| DATE | DEPTH (cm) | | | | | |
|--------|------------|------|------|------|------|------|
| | 30 | 45 | 60 | 90 | 120 | 150 |
| 810615 | 0.23 | 0.02 | 0.02 | 0.04 | 0.01 | 0.07 |
| 810622 | 0.14 | 0.03 | ---- | 0.05 | 0.10 | 0.09 |
| 810629 | ---- | 0.05 | 0.13 | 0.02 | 0.01 | 0.03 |
| 810708 | 0.21 | 0.02 | ---- | 0.02 | 0.04 | 0.04 |
| 810715 | ---- | 0.03 | ---- | 0.08 | 0.02 | 0.04 |
| 810722 | 0.14 | 0.02 | ---- | 0.05 | 0.03 | 0.03 |
| 810728 | 0.04 | 0.08 | ---- | 0.04 | 0.02 | 0.04 |
| 810805 | 0.05 | ---- | ---- | 0.04 | 0.02 | 0.02 |
| 810812 | ---- | ---- | ---- | ---- | ---- | ---- |
| 810819 | ---- | 0.10 | ---- | 0.01 | ---- | ---- |
| 810827 | ---- | 0.02 | ---- | ---- | ---- | ---- |
| 810904 | ---- | ---- | ---- | ---- | ---- | ---- |
| 810929 | ---- | ---- | ---- | ---- | ---- | ---- |
| 811007 | ---- | ---- | ---- | ---- | ---- | ---- |
| 811015 | ---- | ---- | ---- | ---- | ---- | ---- |

SOIL EXTRACT ANALYSIS 1980-1982

| DATE | NH3 -ppm- | | PLOT 50A 1981 | | | |
|--------|------------|------|---------------|------|------|------|
| | DEPTH (cm) | | | | | |
| | 30 | 45 | 60 | 90 | 120 | 150 |
| 810615 | ---- | ---- | ---- | ---- | ---- | ---- |
| 810622 | ---- | ---- | ---- | ---- | ---- | ---- |
| 810629 | ---- | ---- | ---- | ---- | ---- | 0.30 |
| 810708 | ---- | ---- | ---- | ---- | ---- | 0.20 |
| 810715 | ---- | ---- | ---- | ---- | ---- | 1.40 |
| 810722 | ---- | ---- | ---- | ---- | ---- | ---- |
| 810728 | ---- | ---- | ---- | ---- | ---- | 0.60 |
| 810805 | ---- | ---- | ---- | 1.00 | 2.20 | 0.10 |
| 810812 | ---- | ---- | ---- | 0.10 | 0.10 | ---- |
| 810819 | 1.10 | ---- | 1.10 | 0.10 | ---- | ---- |
| 810827 | 0.80 | ---- | 1.00 | ---- | ---- | ---- |
| 810904 | 1.50 | ---- | 1.10 | 0.10 | 0.10 | 0.90 |
| 810929 | ---- | ---- | ---- | ---- | 0.00 | 0.30 |
| 811007 | 0.80 | ---- | ---- | ---- | ---- | ---- |
| 811015 | ---- | ---- | ---- | ---- | 0.50 | 0.30 |

| DATE | NH3 -ppm- | | PLOT 50 1981 | | | |
|--------|------------|------|--------------|------|------|------|
| | DEPTH (cm) | | | | | |
| | 30 | 45 | 60 | 90 | 120 | 150 |
| 810615 | 1.90 | 0.80 | 1.10 | 0.20 | 1.10 | 0.40 |
| 810622 | 0.50 | 0.30 | ---- | 0.30 | 0.30 | 1.40 |
| 810629 | ---- | 0.20 | 0.30 | 0.20 | 0.20 | 0.30 |
| 810708 | 0.30 | 0.50 | ---- | ---- | 0.30 | 0.70 |
| 810715 | ---- | 3.00 | ---- | 0.80 | 0.80 | 1.40 |
| 810722 | 0.50 | 0.60 | 0.60 | 0.50 | 0.50 | 1.20 |
| 810728 | 2.40 | 1.80 | ---- | ---- | 0.60 | 1.00 |
| 810805 | 0.30 | ---- | ---- | 0.20 | 0.70 | 1.40 |
| 810812 | 0.10 | 0.60 | ---- | 0.10 | 0.10 | 3.00 |
| 810819 | 0.10 | 0.04 | ---- | 0.10 | 0.10 | 0.60 |
| 810827 | 0.20 | 0.20 | ---- | ---- | 0.20 | 1.20 |
| 810904 | 0.10 | 0.10 | ---- | ---- | 0.10 | 0.80 |
| 810929 | ---- | ---- | ---- | ---- | ---- | ---- |
| 811007 | ---- | ---- | ---- | 0.80 | ---- | ---- |
| 811015 | 0.20 | ---- | ---- | ---- | 0.70 | ---- |

Appendix C. Laboratory-determined parameters of field soil water extracts 1982.

Sodium
Chloride
Bicarbonate
Electrical Conductivity
Nitrate
P
Total Phosphates
Ammonia

SOIL EXTRACT ANALYSIS 1980-1982

SODIUM (Na) -ppm- PLOT 50A 1982

| DATE | DEPTH (cm) | | | | | |
|--------|------------|------|-------|--------|-------|-------|
| | 30 | 45 | 60 | 90 | 120 | 150 |
| 820618 | ---- | ---- | ---- | ---- | 185.0 | ---- |
| 820625 | 332.0 | ---- | ---- | 1010.0 | 218.0 | 133.0 |
| 820630 | 233.0 | ---- | ---- | 870.0 | 174.0 | 71.0 |
| 820708 | 353.0 | ---- | 409.0 | 650.0 | 307.0 | 103.0 |
| 820725 | 392.0 | ---- | 450.0 | 590.0 | 330.0 | 103.0 |
| 820804 | 426.0 | ---- | 630.0 | 590.0 | 343.0 | 103.0 |
| 820810 | 425.0 | ---- | 510.0 | 530.0 | 367.0 | 103.0 |
| 820820 | 440.0 | ---- | 530.0 | 540.0 | 332.0 | 101.0 |
| 820825 | 400.0 | ---- | 370.0 | 460.0 | 404.0 | 99.0 |

SODIUM (Na) -ppm- PLOT 50 1982

| DATE | DEPTH (cm) | | | | | |
|--------|------------|-------|-------|-------|-------|-------|
| | 30 | 45 | 60 | 90 | 120 | 150 |
| 820618 | 400.0 | ---- | ---- | 121.0 | 204.0 | 127.0 |
| 820625 | 263.0 | ---- | ---- | 540.0 | 268.0 | 167.0 |
| 820630 | ---- | ---- | ---- | ---- | ---- | ---- |
| 820708 | 239.0 | 410.0 | 394.0 | 460.0 | 271.0 | 217.0 |
| 820725 | 368.0 | 366.0 | 420.0 | 530.0 | 294.0 | 222.0 |
| 820804 | 454.0 | 468.0 | 560.0 | 550.0 | 342.0 | 365.0 |
| 820810 | 500.0 | ---- | 450.0 | 480.0 | 266.0 | 375.0 |
| 820820 | 360.0 | 500.0 | 390.0 | 500.0 | 280.0 | ---- |
| 820825 | 410.0 | 630.0 | 370.0 | 520.0 | 333.0 | ---- |

SODIUM (Na) -ppm- PLOT 35G 1982

| DATE | DEPTH (cm) | | | | | |
|--------|------------|-------|-------|-------|-------|-------|
| | 30 | 45 | 60 | 90 | 120 | 150 |
| 820618 | ---- | ---- | ---- | ---- | ---- | ---- |
| 820625 | ---- | 375.0 | 440.0 | 510.0 | ---- | 124.0 |
| 820630 | ---- | ---- | ---- | ---- | 258.0 | 133.0 |
| 820708 | ---- | ---- | 510.0 | ---- | 301.0 | 122.0 |
| 820725 | 303.0 | ---- | 353.0 | 440.0 | 272.0 | 114.0 |
| 820804 | 342.0 | ---- | 327.0 | 530.0 | 322.0 | 86.0 |
| 820810 | ---- | ---- | ---- | 431.0 | 251.0 | 134.0 |
| 820820 | 279.0 | 400.0 | 410.0 | 390.0 | 318.0 | 160.0 |
| 820825 | ---- | 390.0 | 380.0 | 435.0 | 319.0 | 185.0 |

SOIL EXTRACT ANALYSIS 1980-1982

SODIUM (Na) -ppm-

PLOT 35 1982

| DATE | DEPTH (cm) | | | | | |
|--------|------------|-------|-------|------|-------|------|
| | 30 | 45 | 60 | 90 | 120 | 150 |
| 820518 | ---- | 560.0 | ---- | ---- | ---- | ---- |
| 820625 | ---- | 400.0 | 610.0 | ---- | ---- | ---- |
| 820630 | ---- | ---- | ---- | ---- | ---- | ---- |
| 820708 | ---- | 520.0 | 600.0 | ---- | ---- | ---- |
| 820725 | 403.0 | 550.0 | 540.0 | ---- | 315.0 | ---- |
| 820804 | ---- | 550.0 | 540.0 | ---- | ---- | ---- |
| 820810 | ---- | 600.0 | ---- | ---- | 293.0 | ---- |
| 820820 | 620.0 | 520.0 | 610.0 | ---- | 331.0 | ---- |
| 820825 | ---- | 700.0 | 710.0 | ---- | 378.0 | ---- |

CHLORIDE (Cl) -ppm-

PLOT 50A 1982

| DATE | DEPTH (cm) | | | | | |
|--------|------------|------|-------|--------|--------|-------|
| | 30 | 45 | 60 | 90 | 120 | 150 |
| 820618 | ---- | ---- | ---- | ---- | 965.0 | ---- |
| 820625 | 200.0 | ---- | ---- | 1500.0 | 1010.0 | 407.0 |
| 820630 | 260.0 | ---- | ---- | 905.0 | 2180.0 | 430.0 |
| 820708 | 360.0 | ---- | 380.0 | 430.0 | 1065.0 | 430.0 |
| 820725 | 380.0 | ---- | 420.0 | 440.0 | 1010.0 | 450.0 |
| 820804 | 390.0 | ---- | 530.0 | 495.0 | 846.0 | 410.0 |
| 820810 | 395.0 | ---- | 490.0 | 450.0 | 745.0 | 420.0 |
| 820820 | 470.0 | ---- | 495.0 | 400.0 | 740.0 | 465.0 |
| 820825 | 500.0 | ---- | 462.0 | 335.0 | 670.0 | 440.0 |

CHLORIDE (Cl) -ppm-

PLOT 50 1982

| DATE | DEPTH (cm) | | | | | |
|--------|------------|-------|-------|-------|-------|-------|
| | 30 | 45 | 60 | 90 | 120 | 150 |
| 820618 | 465.0 | ---- | ---- | 355.0 | 765.0 | 875.0 |
| 820625 | 120.0 | ---- | ---- | 865.0 | 800.0 | 770.0 |
| 820630 | ---- | ---- | ---- | ---- | ---- | ---- |
| 820708 | 210.0 | 450.0 | 260.0 | 505.0 | 820.0 | 710.0 |
| 820725 | 380.0 | 325.0 | 375.0 | 705.0 | 940.0 | 760.0 |
| 820804 | 450.0 | 530.0 | 425.0 | 540.0 | 895.0 | 605.0 |
| 820810 | 580.0 | ---- | 400.0 | 510.0 | 820.0 | 610.0 |
| 820820 | 430.0 | 580.0 | 430.0 | 510.0 | 860.0 | ---- |
| 820825 | 480.0 | 565.0 | 415.0 | 520.0 | 875.0 | ---- |

CHLORIDE (Cl) -ppm-

PLOT 35G 1982

| DATE | DEPTH (cm) | | | | | |
|--------|------------|-------|-------|--------|--------|-------|
| | 30 | 45 | 60 | 90 | 120 | 150 |
| 820618 | ---- | ---- | ---- | ---- | ---- | ---- |
| 820625 | ---- | 230.0 | 350.0 | 1115.0 | ---- | 970.0 |
| 820630 | ---- | ---- | ---- | ---- | 930.0 | 990.0 |
| 820703 | ---- | ---- | 275.0 | ---- | 1050.0 | 955.0 |
| 820725 | 295.0 | ---- | 230.0 | 375.0 | 1000.0 | 990.0 |
| 820804 | 200.0 | ---- | 220.0 | 315.0 | 960.0 | 920.0 |
| 820810 | ---- | ---- | ---- | 310.0 | 975.0 | 875.0 |
| 820820 | 230.0 | 378.0 | 335.0 | 725.0 | 1025.0 | 330.0 |
| 820825 | ---- | 375.0 | 335.0 | 670.0 | 1025.0 | 755.0 |

CHLORIDE (Cl) -ppm-

PLOT 35 1982

| DATE | DEPTH (cm) | | | | | |
|--------|------------|-------|-------|------|--------|------|
| | 30 | 45 | 60 | 90 | 120 | 150 |
| 820618 | ---- | 290.0 | ---- | ---- | ---- | ---- |
| 820625 | ---- | 70.0 | 370.0 | ---- | ---- | ---- |
| 820630 | ---- | ---- | ---- | ---- | ---- | ---- |
| 820708 | ---- | 200.0 | 200.0 | ---- | ---- | ---- |
| 820725 | 140.0 | 455.0 | 298.0 | ---- | 1550.0 | ---- |
| 820804 | ---- | 440.0 | 410.0 | ---- | ---- | ---- |
| 820810 | ---- | 440.0 | ---- | ---- | 1390.0 | ---- |
| 820820 | 515.0 | 400.0 | 505.0 | ---- | 1410.0 | ---- |
| 820825 | ---- | 455.0 | 585.0 | ---- | 1420.0 | ---- |

BICARBONATE (HCO3) -ppm-

PLOT 50A 1982

| DATE | DEPTH (cm) | | | | | |
|--------|------------|------|-------|-------|-------|-------|
| | 30 | 45 | 60 | 90 | 120 | 150 |
| 820618 | ---- | ---- | ---- | ---- | 515.0 | ---- |
| 820625 | 216.0 | ---- | ---- | 80.0 | 248.0 | 475.0 |
| 820630 | 172.0 | ---- | ---- | 444.0 | 348.0 | 538.0 |
| 820703 | 210.0 | ---- | 252.0 | 525.0 | 230.0 | 630.0 |
| 820725 | 200.0 | ---- | 420.0 | 756.0 | 590.0 | 792.0 |
| 820804 | 145.0 | ---- | 170.0 | 280.0 | 110.0 | 330.0 |
| 820810 | 210.0 | ---- | 330.0 | 720.0 | 405.0 | 420.0 |
| 820820 | 130.0 | ---- | 250.0 | 460.0 | 380.0 | 400.0 |
| 820825 | 220.0 | ---- | 240.0 | 440.0 | 260.0 | 350.0 |

SOIL EXTRACT ANALYSIS 1980-1982

BICARBONATE (HCO₃) -ppm- PLOT 50 1982

| DATE | DEPTH (cm) | | | | | |
|--------|------------|-------|-------|-------|-------|-------|
| | 30 | 45 | 60 | 90 | 120 | 150 |
| 820618 | 140.0 | ---- | ---- | 72.0 | 388.0 | 468.0 |
| 820625 | 146.0 | ---- | ---- | 248.0 | 336.0 | 382.0 |
| 820630 | ---- | ---- | ---- | ---- | ---- | ---- |
| 820708 | 153.0 | 150.0 | 402.0 | 344.0 | 350.0 | 372.0 |
| 820725 | 192.0 | 200.0 | 435.0 | 460.0 | 420.0 | 544.0 |
| 820804 | 120.0 | 180.0 | 140.0 | 135.0 | 110.0 | 150.0 |
| 820810 | 230.0 | ---- | 390.0 | 430.0 | 460.0 | 180.0 |
| 820820 | 200.0 | 260.0 | 220.0 | 230.0 | 320.0 | ---- |
| 820825 | 160.0 | 160.0 | 200.0 | 140.0 | 200.0 | ---- |

BICARBONATE (HCO₃) -ppm- PLOT 35G 1982

| DATE | DEPTH (cm) | | | | | |
|--------|------------|-------|-------|-------|-------|-------|
| | 30 | 45 | 60 | 90 | 120 | 150 |
| 820618 | ---- | ---- | ---- | ---- | ---- | ---- |
| 820625 | ---- | 208.0 | 120.0 | 140.0 | ---- | 556.0 |
| 820630 | ---- | ---- | ---- | ---- | 200.0 | 672.0 |
| 820708 | ---- | ---- | 155.0 | ---- | 428.0 | 622.0 |
| 820725 | 272.0 | ---- | 380.0 | 640.0 | 635.0 | 664.0 |
| 820804 | 250.0 | ---- | 200.0 | 120.0 | 220.0 | 140.0 |
| 820810 | ---- | ---- | ---- | 620.0 | 420.0 | 650.0 |
| 820820 | 230.0 | 240.0 | 260.0 | 440.0 | 350.0 | 460.0 |
| 820825 | ---- | 220.0 | 170.0 | 180.0 | 160.0 | 260.0 |

BICARBONATE (HCO₃) -ppm- PLOT 35 1982

| DATE | DEPTH (cm) | | | | | |
|--------|------------|-------|-------|------|-------|------|
| | 30 | 45 | 60 | 90 | 120 | 150 |
| 820618 | ---- | 468.0 | ---- | ---- | ---- | ---- |
| 820625 | ---- | 344.0 | 144.0 | ---- | ---- | ---- |
| 820630 | ---- | ---- | ---- | ---- | ---- | ---- |
| 820708 | ---- | 375.0 | 210.0 | ---- | ---- | ---- |
| 820725 | 476.0 | 496.0 | 420.0 | ---- | 160.0 | ---- |
| 820804 | ---- | 270.0 | 290.0 | ---- | ---- | ---- |
| 820810 | ---- | 240.0 | ---- | ---- | 90.0 | ---- |
| 820820 | 280.0 | 280.0 | 200.0 | ---- | 100.0 | ---- |
| 820825 | ---- | 400.0 | 260.0 | ---- | 100.0 | ---- |

SOIL EXTRACT ANALYSIS 1980-1982

| CONDUCTIVITY -mS/cm- | | PLOT 50A 1982 | | | | |
|----------------------|------------|---------------|------|------|-----|------|
| DATE | DEPTH (cm) | | | | | |
| | 30 | 45 | 60 | 90 | 120 | 150 |
| 820618 | ---- | ---- | ---- | ---- | 4.8 | ---- |
| 820625 | 1.9 | ---- | ---- | 7.1 | 5.2 | 3.2 |
| 820630 | 2.0 | ---- | ---- | 6.2 | 5.2 | 3.3 |
| 820708 | 2.3 | ---- | 2.9 | 4.6 | 5.7 | 3.3 |
| 820725 | 2.4 | ---- | 2.8 | 3.9 | 5.2 | 3.3 |
| 820804 | 3.0 | ---- | 3.9 | 4.4 | 5.4 | 3.6 |
| 820810 | 3.0 | ---- | 3.9 | 4.0 | 5.1 | 3.6 |
| 820820 | 2.7 | ---- | 3.3 | 3.6 | 4.5 | 3.1 |
| 820825 | 2.8 | ---- | 2.8 | 2.6 | 3.3 | 2.7 |

| CONDUCTIVITY -mS/cm- | | PLOT 50 1982 | | | | |
|----------------------|------------|--------------|------|------|------|------|
| DATE | DEPTH (cm) | | | | | |
| | 30 | 45 | 60 | 90 | 120 | 150 |
| 820618 | 3.0 | ---- | ---- | 1.9 | 4.2 | 4.2 |
| 820625 | 1.6 | ---- | ---- | 5.0 | 4.5 | 4.3 |
| 820630 | ---- | ---- | ---- | ---- | ---- | ---- |
| 820708 | 1.9 | 2.9 | 2.4 | 3.7 | 4.5 | 3.8 |
| 820725 | 2.4 | 2.0 | 2.7 | 4.5 | 4.5 | 4.1 |
| 820804 | 3.2 | 3.2 | 3.3 | 4.1 | 4.7 | 3.9 |
| 820810 | 4.0 | ---- | 3.5 | 4.1 | 5.2 | 4.0 |
| 820820 | 3.0 | 3.7 | 3.0 | 3.6 | 4.7 | ---- |
| 820825 | 2.5 | 2.8 | 2.5 | 2.9 | 3.9 | ---- |

| CONDUCTIVITY -mS/cm- | | PLOT 35G 1982 | | | | |
|----------------------|------------|---------------|------|------|------|------|
| DATE | DEPTH (cm) | | | | | |
| | 30 | 45 | 60 | 90 | 120 | 150 |
| 820618 | ---- | ---- | ---- | ---- | ---- | ---- |
| 820625 | ---- | 3.1 | 3.2 | 5.1 | ---- | 5.5 |
| 820630 | ---- | ---- | ---- | ---- | 4.9 | 5.9 |
| 820708 | ---- | ---- | 2.9 | ---- | 5.5 | 5.8 |
| 820725 | 2.5 | ---- | 2.5 | 5.0 | 5.0 | 5.4 |
| 820804 | 1.8 | ---- | 2.0 | 5.4 | 6.0 | 5.3 |
| 820810 | ---- | ---- | ---- | 6.0 | 6.6 | 5.9 |
| 820820 | 1.8 | 2.7 | 2.4 | 4.7 | 5.5 | 5.2 |
| 820825 | ---- | 2.8 | 2.5 | 3.7 | 4.6 | 4.1 |

SOIL EXTRACT ANALYSIS 1980-1982

| DATE | CONDUCTIVITY -mS/cm- | | | | | |
|--------|----------------------|------|------|------|------|------|
| | PLOT 35 1982 | | | | | |
| | DEPTH (cm) | | | | | |
| | 30 | 45 | 60 | 90 | 120 | 150 |
| 820618 | ---- | 3.1 | ---- | ---- | ---- | ---- |
| 820625 | ---- | 2.2 | 3.6 | ---- | ---- | ---- |
| 820630 | ---- | ---- | ---- | ---- | ---- | ---- |
| 820708 | ---- | 2.4 | 3.0 | ---- | ---- | ---- |
| 820725 | 2.3 | 3.1 | 2.9 | ---- | 5.7 | ---- |
| 820804 | ---- | 3.8 | 3.2 | ---- | ---- | ---- |
| 820810 | ---- | 3.7 | ---- | ---- | 7.1 | ---- |
| 820820 | 3.0 | 2.9 | 2.5 | ---- | 6.4 | ---- |
| 820825 | ---- | 2.8 | 3.8 | ---- | 5.1 | ---- |

| DATE | NITRATE (as N) -ppm- | | | | | |
|--------|----------------------|------|------|------|------|------|
| | PLOT 50A 1982 | | | | | |
| | DEPTH (cm) | | | | | |
| | 30 | 45 | 60 | 90 | 120 | 150 |
| 820618 | ---- | ---- | ---- | ---- | 1.82 | ---- |
| 820625 | 13.40 | ---- | ---- | ---- | 1.68 | 1.76 |
| 820630 | 5.50 | ---- | ---- | ---- | ---- | 1.50 |
| 820708 | 1.25 | ---- | 5.65 | 0.16 | 0.92 | 2.20 |
| 820725 | 0.04 | ---- | 0.05 | 0.04 | 0.45 | 2.00 |
| 820804 | 0.06 | ---- | 0.24 | 0.03 | 0.43 | 1.75 |
| 820810 | 0.06 | ---- | 0.03 | 0.01 | 0.09 | 1.70 |
| 820820 | 0.05 | ---- | 0.05 | 0.02 | 0.01 | 1.65 |
| 820825 | 0.07 | ---- | 0.05 | 0.03 | 0.03 | 1.65 |

| DATE | NITRATE (as N) -ppm- | | | | | |
|--------|----------------------|------|------|-------|------|------|
| | PLOT 50 1982 | | | | | |
| | DEPTH (cm) | | | | | |
| | 30 | 45 | 60 | 90 | 120 | 150 |
| 820618 | 8.75 | ---- | ---- | ---- | 1.98 | 3.23 |
| 820625 | 36.10 | ---- | ---- | 6.40 | 2.35 | 2.25 |
| 820630 | ---- | ---- | ---- | ---- | ---- | ---- |
| 820708 | 18.60 | 4.75 | 4.12 | 35.90 | 1.30 | 5.48 |
| 820725 | 2.65 | 2.00 | 2.13 | 12.20 | 0.46 | 1.14 |
| 820804 | 0.54 | 1.65 | 0.82 | 4.85 | 0.20 | 0.10 |
| 820810 | 0.62 | ---- | 0.66 | 0.03 | 0.03 | 0.03 |
| 820820 | 0.72 | 0.32 | 0.61 | 0.04 | 0.01 | ---- |
| 820825 | 0.46 | 0.53 | 0.40 | 0.02 | 0.02 | ---- |

SOIL EXTRACT ANALYSIS 1980-1982

| DATE | NITRATE (as N) -ppm- | | | | | |
|--------|----------------------|-------|------|------|------|------|
| | PLOT 35G 1982 | | | | | |
| | DEPTH (cm) | | | | | |
| | 30 | 45 | 60 | 90 | 120 | 150 |
| 820618 | ---- | ---- | ---- | ---- | ---- | ---- |
| 820625 | ---- | 13.20 | 1.78 | 0.06 | ---- | 1.14 |
| 820630 | ---- | ---- | ---- | ---- | 0.27 | 0.82 |
| 820708 | ---- | ---- | 1.75 | ---- | 0.40 | 0.98 |
| 820725 | 20.60 | ---- | 1.93 | 0.08 | 0.06 | 1.80 |
| 820804 | 8.35 | ---- | 3.16 | 0.13 | 0.21 | 1.31 |
| 820810 | ---- | ---- | ---- | 0.01 | 0.10 | 0.65 |
| 820820 | 7.85 | 12.80 | 3.58 | 0.04 | 0.06 | 0.60 |
| 820825 | ---- | 3.75 | 3.20 | 0.32 | 0.23 | 0.31 |

| DATE | NITRATE (as N) -ppm- | | | | | |
|--------|----------------------|-------|------|------|------|------|
| | PLOT 35 1982 | | | | | |
| | DEPTH (cm) | | | | | |
| | 30 | 45 | 60 | 90 | 120 | 150 |
| 820618 | ---- | 15.50 | ---- | ---- | ---- | ---- |
| 820625 | ---- | 21.20 | 5.42 | ---- | ---- | ---- |
| 820630 | ---- | ---- | ---- | ---- | ---- | ---- |
| 820708 | ---- | 13.00 | 5.00 | ---- | ---- | ---- |
| 820725 | 2.45 | 3.75 | 3.10 | ---- | 0.22 | ---- |
| 820804 | ---- | 1.53 | 1.45 | ---- | ---- | ---- |
| 820810 | ---- | 1.28 | ---- | ---- | 0.06 | ---- |
| 820820 | 0.33 | 0.79 | 0.65 | ---- | 0.07 | ---- |
| 820825 | ---- | 0.96 | 1.10 | ---- | 0.05 | ---- |

| DATE | PH | | | | | |
|--------|---------------|------|------|------|------|------|
| | PLOT 50A 1982 | | | | | |
| | DEPTH (cm) | | | | | |
| | 30 | 45 | 60 | 90 | 120 | 150 |
| 820618 | ---- | ---- | ---- | ---- | 7.70 | ---- |
| 820625 | 8.50 | ---- | ---- | 7.88 | 7.90 | 8.70 |
| 820630 | 8.54 | ---- | ---- | 7.49 | 7.58 | 8.27 |
| 820708 | 8.40 | ---- | 8.05 | 7.51 | 7.61 | 8.14 |
| 820725 | 8.27 | ---- | 7.81 | 7.30 | 7.53 | 8.00 |
| 820804 | 8.60 | ---- | 8.55 | 8.85 | 8.38 | 9.00 |
| 820810 | 8.58 | ---- | 8.19 | 8.02 | 8.09 | 8.80 |
| 820820 | 8.50 | ---- | 8.49 | 8.60 | 8.15 | 8.85 |
| 820825 | 8.51 | ---- | 8.61 | 8.99 | 8.60 | 9.02 |

SOIL EXTRACT ANALYSIS 1980-1982

| DATE | PH PLOT 50 1982 | | | | | |
|--------|-----------------|------|------|------|------|------|
| | DEPTH (cm) | | | | | |
| | 30 | 45 | 60 | 90 | 120 | 150 |
| 820618 | 7.73 | ---- | ---- | 7.73 | 7.30 | 7.30 |
| 820625 | 8.55 | ---- | ---- | 7.78 | 7.89 | 7.69 |
| 820630 | ---- | ---- | ---- | ---- | ---- | ---- |
| 820708 | 8.34 | 8.32 | 8.51 | 7.48 | 7.62 | 7.60 |
| 820725 | 8.32 | 8.50 | 7.87 | 7.60 | 7.61 | 7.70 |
| 820804 | 8.40 | 8.61 | 8.56 | 8.38 | 8.20 | 8.52 |
| 820810 | 8.50 | ---- | 7.99 | 8.19 | 7.85 | 8.60 |
| 820820 | 3.48 | 8.45 | 8.42 | 8.20 | 8.02 | ---- |
| 820825 | 3.48 | 8.42 | 8.52 | 8.32 | 8.53 | ---- |

| DATE | PH PLOT 35G 1982 | | | | | |
|--------|------------------|------|------|------|------|------|
| | DEPTH (cm) | | | | | |
| | 30 | 45 | 60 | 90 | 120 | 150 |
| 820618 | ---- | ---- | ---- | ---- | ---- | ---- |
| 820625 | ---- | 8.53 | 8.30 | 8.22 | ---- | 7.88 |
| 820630 | ---- | ---- | ---- | ---- | 8.42 | 8.08 |
| 820708 | ---- | ---- | 8.33 | ---- | 8.36 | 7.48 |
| 820725 | 8.29 | ---- | 7.98 | 7.30 | 7.89 | 7.85 |
| 820804 | 8.72 | ---- | 8.70 | 8.35 | 8.52 | 8.46 |
| 820810 | ---- | ---- | ---- | 7.60 | 8.21 | 7.82 |
| 820820 | 8.70 | 8.70 | 8.52 | 8.01 | 8.48 | 8.30 |
| 820825 | ---- | 8.62 | 8.58 | 8.49 | 8.72 | 8.62 |

| DATE | PH PLOT 35 1982 | | | | | |
|--------|-----------------|------|------|------|------|------|
| | DEPTH (cm) | | | | | |
| | 30 | 45 | 60 | 90 | 120 | 150 |
| 820618 | ---- | 7.70 | ---- | ---- | ---- | ---- |
| 820625 | ---- | 8.92 | 8.31 | ---- | ---- | ---- |
| 820630 | ---- | ---- | ---- | ---- | ---- | ---- |
| 820708 | ---- | 8.51 | 8.80 | ---- | ---- | ---- |
| 820725 | 8.70 | 7.90 | 8.41 | ---- | 7.83 | ---- |
| 820804 | ---- | 8.78 | 8.89 | ---- | ---- | ---- |
| 820810 | ---- | 8.61 | ---- | ---- | 8.00 | ---- |
| 820820 | 8.70 | 8.78 | 8.79 | ---- | 8.13 | ---- |
| 820825 | ---- | 8.57 | 8.70 | ---- | 8.07 | ---- |

SOIL EXTRACT ANALYSIS 1980-1982

T-PO4 as P -ppm-

PLOT 50A 1982

| DATE | DEPTH (cm) | | | | | |
|--------|------------|------|------|------|------|------|
| | 30 | 45 | 60 | 90 | 120 | 150 |
| 820618 | ---- | ---- | ---- | ---- | 0.04 | ---- |
| 820625 | 0.06 | ---- | ---- | ---- | 0.01 | ---- |
| 820630 | ---- | ---- | ---- | ---- | 0.04 | 0.03 |
| 820708 | 0.03 | ---- | 0.03 | ---- | ---- | 0.01 |
| 820725 | 0.03 | ---- | 0.04 | 0.05 | 0.02 | ---- |
| 820804 | 0.02 | ---- | 0.02 | 0.01 | ---- | 0.03 |
| 820810 | 0.01 | ---- | 0.03 | 0.03 | 0.04 | 0.08 |
| 820820 | 0.14 | ---- | 0.06 | 0.01 | 0.10 | ---- |
| 820825 | 0.05 | ---- | 0.02 | 0.09 | ---- | ---- |

T-PO4 as P -ppm-

PLOT 50 1982

| DATE | DEPTH (cm) | | | | | |
|--------|------------|------|------|------|------|------|
| | 30 | 45 | 60 | 90 | 120 | 150 |
| 820618 | 0.13 | ---- | ---- | ---- | 0.01 | 0.09 |
| 820625 | ---- | ---- | ---- | 0.04 | 0.05 | 0.01 |
| 820630 | ---- | ---- | ---- | ---- | ---- | ---- |
| 820708 | 0.02 | 0.22 | 0.04 | 0.04 | 0.04 | 0.02 |
| 820725 | 0.12 | ---- | 0.02 | 0.04 | ---- | 0.02 |
| 820804 | ---- | ---- | 0.02 | ---- | ---- | ---- |
| 820810 | ---- | ---- | ---- | ---- | 0.01 | ---- |
| 820820 | ---- | 0.06 | ---- | ---- | ---- | ---- |
| 820825 | 0.01 | ---- | 0.06 | 0.05 | 0.01 | ---- |

T-PO4 as P -ppm-

PLOT 35G 1982

| DATE | DEPTH (cm) | | | | | |
|--------|------------|------|------|------|------|------|
| | 30 | 45 | 60 | 90 | 120 | 150 |
| 820618 | ---- | ---- | ---- | ---- | ---- | ---- |
| 820625 | ---- | ---- | ---- | ---- | ---- | 0.02 |
| 820630 | ---- | ---- | ---- | ---- | 0.05 | 0.08 |
| 820708 | ---- | ---- | ---- | ---- | 0.11 | 0.03 |
| 820725 | ---- | ---- | ---- | ---- | 0.06 | 0.02 |
| 820804 | ---- | ---- | ---- | ---- | 0.02 | 0.01 |
| 820810 | ---- | ---- | ---- | 0.03 | 0.03 | 0.07 |
| 820820 | ---- | ---- | ---- | ---- | ---- | 0.20 |
| 820825 | ---- | 0.05 | 0.02 | ---- | ---- | 0.05 |

SOIL EXTRACT ANALYSIS 1980-1982

T-PO4 as P -ppm-

PLOT 35 1982

| DATE | DEPTH (cm) | | | | | |
|--------|------------|------|------|------|------|------|
| | 30 | 45 | 60 | 90 | 120 | 150 |
| 820618 | ---- | 0.13 | ---- | ---- | ---- | ---- |
| 820625 | ---- | 0.01 | ---- | ---- | ---- | ---- |
| 820630 | ---- | ---- | ---- | ---- | ---- | ---- |
| 820708 | ---- | ---- | 0.70 | ---- | ---- | ---- |
| 820725 | ---- | 0.01 | ---- | ---- | ---- | ---- |
| 820804 | ---- | ---- | ---- | ---- | ---- | ---- |
| 820810 | ---- | ---- | ---- | ---- | ---- | ---- |
| 820820 | ---- | ---- | ---- | ---- | ---- | ---- |
| 820825 | ---- | ---- | ---- | ---- | ---- | ---- |

NH3 as N -ppm-

PLOT 50A 1982

| DATE | DEPTH (cm) | | | | | |
|--------|------------|------|------|------|------|------|
| | 30 | 45 | 60 | 90 | 120 | 150 |
| 820618 | ---- | ---- | ---- | ---- | 0.60 | ---- |
| 820625 | 1.20 | ---- | ---- | ---- | 0.14 | 0.90 |
| 820630 | 0.20 | ---- | ---- | 0.39 | 2.31 | 0.51 |
| 820708 | 0.40 | ---- | 0.72 | 0.65 | 0.45 | 0.49 |
| 820725 | 0.22 | ---- | 0.23 | 0.18 | 0.10 | 0.10 |
| 820804 | 0.30 | ---- | 0.11 | ---- | ---- | ---- |
| 820810 | 0.20 | ---- | 0.21 | 0.18 | 0.01 | 0.19 |
| 820820 | 0.70 | ---- | 0.01 | ---- | ---- | ---- |
| 820825 | 0.20 | ---- | 0.09 | 0.11 | 0.05 | ---- |

NH3 as N -ppm-

PLOT 50 1982

| DATE | DEPTH (cm) | | | | | |
|--------|------------|------|------|------|------|------|
| | 30 | 45 | 60 | 90 | 120 | 150 |
| 820618 | 0.06 | ---- | ---- | ---- | 0.53 | 0.02 |
| 820625 | 0.20 | ---- | ---- | 0.07 | 0.20 | 0.10 |
| 820630 | ---- | ---- | ---- | ---- | ---- | ---- |
| 820708 | 0.21 | ---- | 0.24 | 0.58 | 0.46 | 0.66 |
| 820725 | 0.14 | 1.38 | 0.22 | 0.19 | 0.21 | 0.26 |
| 820804 | 0.10 | 0.20 | 0.01 | 0.04 | ---- | 0.41 |
| 820810 | 0.16 | ---- | 0.04 | 0.15 | 0.15 | 0.50 |
| 820820 | 0.16 | 0.19 | ---- | 0.20 | 0.24 | ---- |
| 820825 | 0.26 | 0.01 | 0.06 | 0.13 | 0.20 | ---- |

SOIL EXTRACT ANALYSIS 1980-1982

NH₃ as N -ppm-

PLOT 35G 1982

| DATE | DEPTH (cm) | | | | | |
|--------|------------|------|------|------|------|------|
| | 30 | 45 | 60 | 90 | 120 | 150 |
| 820618 | ---- | ---- | ---- | ---- | ---- | ---- |
| 820625 | ---- | 0.60 | 0.50 | 4.00 | ---- | 0.09 |
| 820630 | ---- | ---- | ---- | ---- | 0.30 | 0.71 |
| 820708 | ---- | ---- | ---- | ---- | 0.44 | 0.93 |
| 820725 | 0.18 | ---- | 0.33 | 0.33 | 0.15 | 0.14 |
| 820804 | 0.30 | ---- | 0.15 | 0.19 | 0.06 | 0.04 |
| 820810 | ---- | ---- | ---- | 0.15 | ---- | 0.08 |
| 820820 | 0.30 | 0.80 | 0.01 | 0.01 | 0.30 | 0.14 |
| 820825 | ---- | 0.20 | 0.09 | 0.04 | ---- | ---- |

NH₃ as N -ppm-

PLOT 35 1982

| DATE | DEPTH (cm) | | | | | |
|--------|------------|------|------|------|------|------|
| | 30 | 45 | 60 | 90 | 120 | 150 |
| 820618 | ---- | 0.20 | ---- | ---- | ---- | ---- |
| 820625 | ---- | 0.50 | 2.00 | ---- | ---- | ---- |
| 820630 | ---- | ---- | ---- | ---- | ---- | ---- |
| 820703 | ---- | 0.60 | 0.50 | ---- | ---- | ---- |
| 820725 | 5.00 | 1.38 | 0.60 | ---- | 2.20 | ---- |
| 820804 | ---- | 0.27 | 0.50 | ---- | ---- | ---- |
| 820810 | ---- | 0.40 | ---- | ---- | ---- | ---- |
| 820820 | 2.00 | 0.70 | 0.70 | ---- | 0.80 | ---- |
| 820825 | ---- | ---- | 0.70 | ---- | ---- | ---- |

Appendix D. Soil chemical characteristics 1980-1982. Data by treatments, depth, and sampling date for:

Exchangeable sodium
Exchangeable Sodium Percentage (ESP)
Cation Exchange Capacity
Exchangeable Magnesium
Exchangeable Calcium
Electrical Conductivity of Saturation Extract
pH of Saturated Soil Paste
Sodium Adsorption Ratio (SAR) of Soil Solution

Exchangeable Sodium, me/100g

PLOT 50

| DATE | SITE | DEPTH (cm) | | | | | | |
|--------|------|------------|------|-------|------|-------|-------|--------|
| | | 0-3 | 0-15 | 15-30 | 0-30 | 30-60 | 60-90 | 90-120 |
| 800519 | 1 | --- | --- | --- | 0.8 | 0.4 | 0.3 | 0.3 |
| 800519 | 2 | --- | --- | --- | 0.8 | 0.4 | 0.1 | 0.1 |
| 800519 | 3 | --- | --- | --- | 0.9 | 0.4 | 0.1 | 0.1 |
| 801104 | 1 | --- | --- | --- | 1.3 | 0.4 | 0.4 | 0.4 |
| 801104 | 2 | --- | --- | --- | 1.5 | 0.8 | 0.6 | 0.2 |
| 801104 | 3 | --- | --- | --- | 1.6 | 0.6 | 0.3 | 0.1 |
| 811009 | 1 | --- | --- | --- | 2.0 | 1.1 | 1.4 | 0.8 |
| 811009 | 2 | --- | --- | --- | 1.7 | 1.4 | 0.8 | 0.7 |
| 811009 | 3 | --- | --- | --- | 1.8 | 1.6 | 0.9 | 0.3 |
| 820426 | 1 | --- | 1.9 | 2.4 | --- | --- | --- | --- |
| 820426 | 3 | --- | 1.9 | 2.1 | --- | --- | --- | --- |
| 820426 | 5 | --- | 1.8 | 2.1 | --- | --- | --- | --- |
| 820426 | 6 | --- | 2.2 | 2.2 | --- | --- | --- | --- |
| 820911 | 1 | 1.3 | 1.7 | 1.7 | --- | 1.6 | 1.7 | 2.2 |
| 820911 | 2 | 1.7 | 1.8 | 2.2 | --- | 1.8 | 1.2 | 1.4 |

Exchangeable Sodium, me/100g

PLOT 35

| DATE | SITE | DEPTH (cm) | | | | | | |
|--------|------|------------|------|-------|------|-------|-------|--------|
| | | 0-3 | 0-15 | 15-30 | 0-30 | 30-60 | 60-90 | 90-120 |
| 800519 | 1 | --- | --- | --- | 0.7 | 0.2 | 0.1 | 0.1 |
| 800519 | 2 | --- | --- | --- | 0.5 | 0.1 | 0.1 | 0.2 |
| 800519 | 3 | --- | --- | --- | 0.4 | 0.2 | 0.3 | 0.5 |
| 801104 | 1 | --- | --- | --- | --- | 0.9 | 0.3 | --- |
| 801104 | 2 | --- | --- | --- | 1.1 | 0.2 | 0.4 | 0.4 |
| 801104 | 3 | --- | --- | --- | 1.6 | 0.4 | 0.7 | 0.8 |
| 811009 | 1 | --- | --- | --- | 1.9 | 1.6 | --- | --- |
| 811009 | 2 | --- | --- | --- | 1.5 | 1.3 | 0.8 | 0.6 |
| 811009 | 3 | --- | --- | --- | 1.7 | 1.4 | --- | --- |
| 820426 | 1 | --- | 1.7 | 2.2 | --- | --- | --- | --- |
| 820426 | 3 | --- | 1.5 | 2.1 | --- | --- | --- | --- |
| 820426 | 5 | --- | 1.9 | 2.1 | --- | --- | --- | --- |
| 820426 | 6 | --- | 1.8 | 2.1 | --- | --- | --- | --- |
| 820911 | 1 | 1.2 | 1.6 | 1.7 | --- | 1.8 | --- | --- |
| 820911 | 2 | 1.3 | 1.5 | 1.8 | --- | 1.6 | 1.9 | 1.0 |

| Exchangeable Sodium, me/100g | | | | PLOT 35G | | | | |
|------------------------------|------|------------|------|----------|------|-------|-------|--------|
| DATE | SITE | DEPTH (cm) | | | | | | |
| | | 0-3 | 0-15 | 15-30 | 0-30 | 30-60 | 60-90 | 90-120 |
| 800519 | 1 | --- | --- | --- | 0.4 | 0.1 | 0.1 | --- |
| 800519 | 2 | --- | --- | --- | 0.5 | 0.2 | 0.6 | 1.3 |
| 800519 | 3 | --- | --- | --- | 0.5 | 0.4 | 0.5 | --- |
| 801104 | 3 | --- | --- | --- | --- | --- | 0.3 | --- |
| 811009 | 1 | --- | --- | --- | 2.2 | 1.1 | 0.9 | 0.5 |
| 811009 | 2 | --- | --- | --- | 2.0 | 1.4 | 0.7 | 0.4 |
| 811009 | 3 | --- | --- | --- | 2.3 | 1.2 | 0.5 | 0.7 |
| 820426 | 1 | --- | 1.6 | 2.0 | --- | --- | --- | --- |
| 820426 | 3 | --- | 1.7 | 2.4 | --- | --- | --- | --- |
| 820426 | 4 | --- | 1.7 | 2.2 | --- | --- | --- | --- |
| 820426 | 5 | --- | 1.4 | 2.2 | --- | --- | --- | --- |
| 820911 | 1 | 0.8 | 1.7 | 1.8 | --- | 1.8 | 1.9 | 1.2 |
| 820911 | 2 | 1.3 | 1.4 | 2.0 | --- | 1.7 | 1.4 | 0.9 |

| Exchangeable Sodium, me/100g | | | | PLOT 20 | | | | |
|------------------------------|------|------------|------|---------|------|-------|-------|--------|
| DATE | SITE | DEPTH (cm) | | | | | | |
| | | 0-3 | 0-15 | 15-30 | 0-30 | 30-60 | 60-90 | 90-120 |
| 800519 | 1 | --- | --- | --- | 0.3 | 0.1 | 0.2 | 0.5 |
| 800519 | 2 | --- | --- | --- | 0.6 | 0.4 | 0.6 | --- |
| 800519 | 3 | --- | --- | --- | 0.4 | 0.1 | --- | --- |
| 801104 | 1 | --- | --- | --- | 1.4 | 0.5 | 0.3 | 1.1 |
| 801104 | 2 | --- | --- | --- | --- | --- | 0.6 | --- |
| 801104 | 3 | --- | --- | --- | --- | 0.6 | --- | --- |
| 811009 | 1 | --- | --- | --- | 3.3 | 1.4 | 1.7 | 1.1 |
| 811009 | 2 | --- | --- | --- | 3.3 | 1.5 | 1.5 | --- |
| 811009 | 3 | --- | --- | --- | 2.9 | 1.5 | --- | --- |
| 820426 | 1 | --- | 2.3 | 2.7 | --- | --- | --- | --- |
| 820426 | 3 | --- | 2.5 | 2.6 | --- | --- | --- | --- |
| 820911 | 1 | 0.8 | 1.5 | 2.6 | --- | 1.6 | 0.9 | 0.8 |
| 820911 | 2 | 1.2 | 1.6 | 2.0 | --- | 1.2 | 0.6 | 0.7 |

Exchangeable Sodium Percentage ESP

PLOT 50

| DATE | SITE | DEPTH (cm) | | | | | | |
|--------|------|------------|------|-------|------|-------|-------|--------|
| | | 0-3 | 0-15 | 15-30 | 0-30 | 30-60 | 60-90 | 90-120 |
| 800519 | 1 | --- | --- | --- | 4.6 | 2.5 | 2.3 | 1.4 |
| 800519 | 2 | --- | --- | --- | 4.0 | 2.3 | 1.3 | 1.3 |
| 800519 | 3 | --- | --- | --- | 5.4 | 2.2 | 1.0 | 0.7 |
| 801104 | 1 | --- | --- | --- | 7.7 | 4.4 | 3.4 | 2.3 |
| 801104 | 2 | --- | --- | --- | 8.3 | 7.4 | 4.1 | 1.4 |
| 801104 | 3 | --- | --- | --- | 7.4 | 4.4 | 4.9 | 1.5 |
| 811009 | 1 | --- | --- | --- | 12.0 | 8.3 | 13.2 | 4.7 |
| 811009 | 2 | --- | --- | --- | 9.0 | 10.5 | 6.5 | 6.0 |
| 811009 | 3 | --- | --- | --- | 9.7 | 10.5 | 11.0 | 3.7 |
| 820426 | 1 | --- | 7.9 | 11.3 | --- | --- | --- | --- |
| 820426 | 3 | --- | 9.0 | 10.8 | --- | --- | --- | --- |
| 820426 | 5 | --- | 8.1 | 11.5 | --- | --- | --- | --- |
| 820426 | 6 | --- | 10.1 | 10.7 | --- | --- | --- | --- |
| 820911 | 1 | 6.1 | 7.5 | 9.0 | --- | 9.4 | 10.3 | 12.8 |
| 820911 | 2 | 7.6 | 7.9 | 11.3 | --- | 10.6 | 7.5 | 8.1 |

Exchangeable Sodium Percentage ESP

PLOT 35

| DATE | SITE | DEPTH (cm) | | | | | | |
|--------|------|------------|------|-------|------|-------|-------|--------|
| | | 0-3 | 0-15 | 15-30 | 0-30 | 30-60 | 60-90 | 90-120 |
| 800519 | 1 | --- | --- | --- | 3.6 | 1.1 | 0.4 | 0.6 |
| 800519 | 2 | --- | --- | --- | 3.5 | 0.4 | 0.6 | 1.2 |
| 800519 | 3 | --- | --- | --- | 2.1 | 1.0 | 2.4 | 3.7 |
| 801104 | 1 | --- | --- | --- | --- | 5.9 | 2.3 | --- |
| 801104 | 2 | --- | --- | --- | 5.5 | 1.5 | 2.5 | 2.4 |
| 801104 | 3 | --- | --- | --- | 9.1 | 2.3 | 6.0 | 4.5 |
| 811009 | 1 | --- | --- | --- | 9.6 | 10.8 | --- | --- |
| 811009 | 2 | --- | --- | --- | 8.4 | 8.9 | 6.3 | 4.3 |
| 811009 | 3 | --- | --- | --- | 9.6 | 8.1 | --- | --- |
| 820426 | 1 | --- | 9.0 | 11.3 | --- | --- | --- | --- |
| 820426 | 3 | --- | 8.2 | 10.1 | --- | --- | --- | --- |
| 820426 | 5 | --- | 9.0 | 10.8 | --- | --- | --- | --- |
| 820426 | 6 | --- | 9.1 | 10.7 | --- | --- | --- | --- |
| 820911 | 1 | 5.5 | 7.6 | 8.0 | --- | 10.0 | --- | --- |
| 820911 | 2 | 6.1 | 7.1 | 8.3 | --- | 9.8 | 15.8 | 7.0 |

Exchangeable Sodium Percentage ESP

PLOT 35G

| DATE | SITE | DEPTH(cm) | | | | | | |
|--------|------|-----------|------|-------|------|-------|-------|--------|
| | | 0-3 | 0-15 | 15-30 | 0-30 | 30-60 | 60-90 | 90-120 |
| 800519 | 1 | --- | --- | --- | 1.9 | 0.3 | 1.2 | --- |
| 800519 | 2 | --- | --- | --- | 2.7 | 1.2 | 3.7 | 7.9 |
| 800519 | 3 | --- | --- | --- | 2.1 | 1.9 | 3.0 | --- |
| 801104 | 3 | --- | --- | --- | --- | --- | 1.6 | --- |
| 811009 | 1 | --- | --- | --- | 11.9 | 6.7 | 10.0 | 5.3 |
| 811009 | 2 | --- | --- | --- | 10.1 | 7.9 | 4.8 | 2.6 |
| 811009 | 3 | --- | --- | --- | 11.0 | 6.0 | 3.1 | 4.8 |
| 820426 | 1 | --- | 7.7 | 10.1 | --- | --- | --- | --- |
| 820426 | 3 | --- | 7.5 | 10.3 | --- | --- | --- | --- |
| 820426 | 4 | --- | 7.6 | 10.5 | --- | --- | --- | --- |
| 820426 | 5 | --- | 6.7 | 10.8 | --- | --- | --- | --- |
| 820911 | 1 | 3.0 | 8.2 | 8.5 | --- | 9.3 | 10.9 | 9.1 |
| 820911 | 2 | 5.1 | 6.7 | 9.5 | --- | 8.5 | 7.7 | 7.0 |

Exchangeable Sodium Percentage ESP

PLOT 20

| DATE | SITE | DEPTH(cm) | | | | | | |
|--------|------|-----------|------|-------|------|-------|-------|--------|
| | | 0-3 | 0-15 | 15-30 | 0-30 | 30-60 | 60-90 | 90-120 |
| 800519 | 1 | --- | --- | --- | 1.7 | 0.8 | 1.7 | 3.4 |
| 800519 | 2 | --- | --- | --- | 2.5 | 2.2 | 4.0 | --- |
| 800519 | 3 | --- | --- | --- | 1.9 | 0.4 | --- | --- |
| 801104 | 1 | --- | --- | --- | 6.7 | 3.4 | 2.9 | 8.1 |
| 801104 | 2 | --- | --- | --- | --- | --- | 5.0 | --- |
| 801104 | 3 | --- | --- | --- | --- | 3.3 | --- | --- |
| 811009 | 1 | --- | --- | --- | 16.6 | 9.5 | 13.7 | 8.1 |
| 811009 | 2 | --- | --- | --- | 14.9 | 7.7 | 10.3 | --- |
| 811009 | 3 | --- | --- | --- | 15.6 | 6.9 | --- | --- |
| 820426 | 1 | --- | 10.4 | 11.9 | --- | --- | --- | --- |
| 820426 | 3 | --- | 11.6 | 10.6 | --- | --- | --- | --- |
| 820911 | 1 | 3.3 | 6.5 | 11.5 | --- | 3.6 | 6.1 | 5.7 |
| 820911 | 2 | 4.8 | 7.3 | 8.8 | --- | 6.5 | 4.0 | 5.0 |

Cation Exch Capacity(CEC),me/100g

PLOT 50

| DATE | SITE | DEPTH (cm) | | | | | | |
|--------|------|------------|------|-------|------|-------|-------|--------|
| | | 0-3 | 0-15 | 15-30 | 0-30 | 30-60 | 60-90 | 90-120 |
| 800519 | 1 | --- | --- | --- | 16.8 | 16.8 | 11.5 | 18.2 |
| 800519 | 2 | --- | --- | --- | 19.9 | 15.8 | 9.4 | 10.4 |
| 800519 | 3 | --- | --- | --- | 15.7 | 17.2 | 9.9 | 9.1 |
| 801104 | 1 | --- | --- | --- | 17.0 | 9.8 | 10.3 | 17.4 |
| 801104 | 2 | --- | --- | --- | 16.9 | 10.9 | 14.8 | 12.2 |
| 801104 | 3 | --- | --- | --- | 21.2 | 13.0 | 6.3 | 9.1 |
| 811009 | 1 | --- | --- | --- | 16.9 | 13.3 | 10.9 | 17.8 |
| 811009 | 2 | --- | --- | --- | 18.4 | 13.4 | 12.1 | 11.3 |
| 811009 | 3 | --- | --- | --- | 18.4 | 15.1 | 8.1 | 9.1 |
| 820426 | 1 | --- | 23.6 | 21.2 | --- | --- | --- | --- |
| 820426 | 3 | --- | 20.5 | 19.4 | --- | --- | --- | --- |
| 820426 | 5 | --- | 21.8 | 18.2 | --- | --- | --- | --- |
| 820426 | 6 | --- | 21.8 | 21.0 | --- | --- | --- | --- |
| 820911 | 1 | 22.0 | 22.2 | 19.3 | --- | 16.9 | 16.0 | 17.5 |
| 820911 | 2 | 22.0 | 22.2 | 19.3 | --- | 17.0 | 16.0 | 17.5 |

Cation Exch Capacity(CEC),me/100g

PLOT 35

| DATE | SITE | DEPTH (cm) | | | | | | |
|--------|------|------------|------|-------|------|-------|-------|--------|
| | | 0-3 | 0-15 | 15-30 | 0-30 | 30-60 | 60-90 | 90-120 |
| 800519 | 1 | --- | --- | --- | 19.7 | 15.4 | 13.3 | 14.6 |
| 800519 | 2 | --- | --- | --- | 14.2 | 13.3 | 10.1 | 12.7 |
| 800519 | 3 | --- | --- | --- | 18.5 | 16.3 | 11.9 | 14.5 |
| 801104 | 1 | --- | --- | --- | --- | 14.7 | 11.7 | --- |
| 801104 | 2 | --- | --- | --- | 20.5 | 14.9 | 15.3 | 17.0 |
| 801104 | 3 | --- | --- | --- | 17.0 | 16.9 | 11.3 | 17.1 |
| 811009 | 1 | --- | --- | --- | 19.7 | 15.1 | --- | --- |
| 811009 | 2 | --- | --- | --- | 17.3 | 14.1 | 12.7 | 14.8 |
| 811009 | 3 | --- | --- | --- | 17.7 | 16.6 | --- | --- |
| 820426 | 1 | --- | 19.3 | 19.5 | --- | --- | --- | --- |
| 820426 | 3 | --- | 18.7 | 20.5 | --- | --- | --- | --- |
| 820426 | 5 | --- | 21.2 | 19.4 | --- | --- | --- | --- |
| 820426 | 6 | --- | 19.7 | 20.0 | --- | --- | --- | --- |
| 820911 | 1 | 21.0 | 21.5 | 21.3 | --- | 17.7 | --- | --- |
| 820911 | 2 | 21.0 | 21.5 | 21.3 | --- | 17.7 | 12.0 | 13.9 |

Chemical soil analysis 1980-1982

Exchangeable Magnesium, me/100g

PLOT 35G

| DATE | SITE | DEPTH (cm) | | | | | | |
|--------|------|------------|------|-------|------|-------|-------|--------|
| | | 0-3 | 0-15 | 15-30 | 0-30 | 30-60 | 60-90 | 90-120 |
| 800519 | 1 | --- | --- | --- | 4.6 | 5.7 | 3.4 | --- |
| 800519 | 2 | --- | --- | --- | 4.5 | 6.4 | 10.0 | 13.6 |
| 800519 | 3 | --- | --- | --- | 5.1 | 6.6 | 9.2 | --- |
| 801104 | 3 | --- | --- | --- | --- | --- | 7.8 | --- |
| 820426 | 1 | --- | 4.0 | 4.2 | --- | --- | --- | --- |
| 820426 | 3 | --- | 4.3 | 4.0 | --- | --- | --- | --- |
| 820426 | 4 | --- | 4.4 | 4.4 | --- | --- | --- | --- |
| 820426 | 5 | --- | 4.3 | 4.6 | --- | --- | --- | --- |
| 820911 | 1 | 4.6 | 6.1 | 6.9 | --- | 7.8 | 9.6 | 11.4 |
| 820911 | 2 | 5.8 | 5.7 | 4.1 | --- | 4.3 | 7.9 | 8.0 |

Exchangeable Magnesium, me/100g

PLOT 20

| DATE | SITE | DEPTH (cm) | | | | | | |
|--------|------|------------|------|-------|------|-------|-------|--------|
| | | 0-3 | 0-15 | 15-30 | 0-30 | 30-60 | 60-90 | 90-120 |
| 800519 | 1 | --- | --- | --- | 5.6 | 9.8 | 9.7 | 13.7 |
| 800519 | 2 | --- | --- | --- | 5.5 | 4.9 | 14.3 | --- |
| 800519 | 3 | --- | --- | --- | 4.8 | 4.9 | --- | --- |
| 801104 | 1 | --- | --- | --- | 6.8 | 10.9 | 4.0 | 13.8 |
| 801104 | 2 | --- | --- | --- | --- | --- | 13.6 | --- |
| 801104 | 3 | --- | --- | --- | --- | 6.9 | --- | --- |
| 820426 | 1 | --- | 5.4 | 5.5 | --- | --- | --- | --- |
| 820426 | 3 | --- | 4.9 | 5.3 | --- | --- | --- | --- |
| 820911 | 1 | 6.0 | 5.1 | 4.0 | --- | 5.3 | 11.2 | 14.2 |
| 820911 | 2 | 6.9 | 5.9 | 4.5 | --- | 5.4 | 6.6 | 9.2 |

Exchangeable Magnesium, me/100g

PLOT 50

| DATE | SITE | DEPTH (cm) | | | | | | |
|--------|------|------------|------|-------|------|-------|-------|--------|
| | | 0-3 | 0-15 | 15-30 | 0-30 | 30-60 | 60-90 | 90-120 |
| 800519 | 1 | --- | --- | --- | 4.4 | 4.6 | 8.1 | 17.2 |
| 800519 | 2 | --- | --- | --- | 3.3 | 1.9 | 2.7 | 6.8 |
| 800519 | 3 | --- | --- | --- | 3.7 | 5.5 | 4.1 | 4.4 |
| 801104 | 1 | --- | --- | --- | 4.3 | 4.7 | 5.7 | 17.0 |
| 801104 | 2 | --- | --- | --- | 4.7 | 3.9 | 6.7 | 10.4 |
| 801104 | 3 | --- | --- | --- | 4.0 | 3.6 | 2.9 | 5.7 |
| 820426 | 1 | --- | 6.3 | 6.7 | --- | --- | --- | --- |
| 820426 | 3 | --- | 5.1 | 4.9 | --- | --- | --- | --- |
| 820426 | 5 | --- | 5.0 | 4.3 | --- | --- | --- | --- |
| 820426 | 6 | --- | 5.0 | 4.6 | --- | --- | --- | --- |
| 820911 | 1 | 5.4 | 3.8 | 4.2 | --- | 3.7 | 4.9 | 9.0 |
| 820911 | 2 | 6.5 | 4.7 | 2.8 | --- | 2.6 | 2.6 | 6.8 |

Exchangeable Magnesium, me/100g

PLOT 35

| DATE | SITE | DEPTH (cm) | | | | | | |
|--------|------|------------|------|-------|------|-------|-------|--------|
| | | 0-3 | 0-15 | 15-30 | 0-30 | 30-60 | 60-90 | 90-120 |
| 800519 | 1 | --- | --- | --- | 3.3 | 4.8 | 6.9 | 8.3 |
| 800519 | 2 | --- | --- | --- | 2.9 | 2.7 | 3.7 | 4.4 |
| 800519 | 3 | --- | --- | --- | 5.4 | 6.6 | 6.4 | 12.0 |
| 801104 | 1 | --- | --- | --- | --- | 4.6 | 9.2 | --- |
| 801104 | 2 | --- | --- | --- | 6.2 | 9.0 | 12.3 | 12.1 |
| 801104 | 3 | --- | --- | --- | 4.5 | 10.7 | 10.8 | 12.5 |
| 820426 | 1 | --- | 4.6 | 5.1 | --- | --- | --- | --- |
| 820426 | 3 | --- | 5.2 | 4.4 | --- | --- | --- | --- |
| 820426 | 5 | --- | 4.9 | 4.2 | --- | --- | --- | --- |
| 820426 | 6 | --- | 4.1 | 4.4 | --- | --- | --- | --- |
| 820911 | 1 | 6.4 | 4.7 | 4.0 | --- | 4.8 | --- | --- |
| 820911 | 2 | 7.3 | 5.7 | 5.5 | --- | 5.6 | 8.6 | 13.2 |

Cation Exch Capacity(CEC),me/100g

PLOT 35G

| DATE | SITE | DEPTH(cm) | | | | | | |
|--------|------|-----------|------|-------|------|-------|-------|--------|
| | | 0-3 | 0-15 | 15-30 | 0-30 | 30-60 | 60-90 | 90-120 |
| 800519 | 1 | --- | --- | --- | 18.3 | 17.0 | 9.3 | --- |
| 800519 | 2 | --- | --- | --- | 19.4 | 18.1 | 15.5 | 16.2 |
| 800519 | 3 | --- | --- | --- | 21.1 | 20.2 | 15.8 | --- |
| 801104 | 3 | --- | --- | --- | --- | --- | 16.8 | --- |
| 811009 | 1 | --- | --- | --- | 18.3 | 17.0 | 9.3 | 8.5 |
| 811009 | 2 | --- | --- | --- | 19.4 | 18.1 | 15.5 | 16.2 |
| 811009 | 3 | --- | --- | --- | 21.1 | 20.2 | 15.8 | 14.0 |
| 820426 | 1 | --- | 20.5 | 19.5 | --- | --- | --- | --- |
| 820426 | 3 | --- | 22.8 | 22.7 | --- | --- | --- | --- |
| 820426 | 4 | --- | 21.6 | 20.9 | --- | --- | --- | --- |
| 820426 | 5 | --- | 20.6 | 20.0 | --- | --- | --- | --- |
| 820911 | 1 | 25.2 | 21.0 | 20.8 | --- | 19.6 | 17.8 | 12.9 |
| 820911 | 2 | 25.0 | 21.0 | 20.8 | --- | 19.6 | 17.8 | 12.9 |

Cation Exch Capacity(CEC),me/100g

PLOT 20

| DATE | SITE | DEPTH(cm) | | | | | | |
|--------|------|-----------|------|-------|------|-------|-------|--------|
| | | 0-3 | 0-15 | 15-30 | 0-30 | 30-60 | 60-90 | 90-120 |
| 800519 | 1 | --- | --- | --- | 19.0 | 15.8 | 13.4 | 13.7 |
| 800519 | 2 | --- | --- | --- | 22.2 | 18.9 | 14.8 | --- |
| 800519 | 3 | --- | --- | --- | 18.4 | 22.3 | --- | --- |
| 801104 | 1 | --- | --- | --- | 21.2 | 13.5 | 11.1 | 14.1 |
| 801104 | 2 | --- | --- | --- | --- | --- | 12.0 | --- |
| 801104 | 3 | --- | --- | --- | --- | 17.6 | --- | --- |
| 811009 | 1 | --- | --- | --- | 20.1 | 14.7 | 12.2 | 13.9 |
| 811009 | 2 | --- | --- | --- | 22.2 | 18.9 | 14.8 | --- |
| 811009 | 3 | --- | --- | --- | 18.4 | 22.3 | --- | --- |
| 820426 | 1 | --- | 21.7 | 23.0 | --- | --- | --- | --- |
| 820426 | 3 | --- | 21.6 | 24.1 | --- | --- | --- | --- |
| 820911 | 1 | 24.6 | 22.4 | 23.0 | --- | 19.0 | 14.0 | 13.5 |
| 820911 | 2 | 24.6 | 22.4 | 23.0 | --- | 19.0 | 14.0 | 13.5 |

Chemical soil analysis 1980-1982

Exchangeable Calcium, me/100g

PLOT 50

| DATE | SITE | DEPTH (cm) | | | | | | |
|--------|------|------------|------|-------|------|-------|-------|--------|
| | | 0-3 | 0-15 | 15-30 | 0-30 | 30-60 | 60-90 | 90-120 |
| 800519 | 1 | --- | --- | --- | 14.2 | 42.7 | 47.2 | 43.0 |
| 800519 | 2 | --- | --- | --- | 14.0 | 18.5 | 43.5 | 44.3 |
| 800519 | 3 | --- | --- | --- | 20.2 | 21.9 | 31.8 | 26.6 |
| 801104 | 1 | --- | --- | --- | 17.2 | 41.2 | 37.5 | 47.4 |
| 801104 | 2 | --- | --- | --- | 14.6 | 25.4 | 46.0 | 40.7 |
| 801104 | 3 | --- | --- | --- | 18.6 | 36.6 | 38.6 | 33.0 |
| 820426 | 1 | --- | 16.1 | 18.7 | --- | --- | --- | --- |
| 820426 | 3 | --- | 15.3 | 14.5 | --- | --- | --- | --- |
| 820426 | 5 | --- | 12.5 | 12.3 | --- | --- | --- | --- |
| 820426 | 6 | --- | 14.7 | 15.8 | --- | --- | --- | --- |
| 820911 | 1 | 15.7 | 12.8 | 18.3 | --- | 35.6 | 45.3 | 42.3 |
| 820911 | 2 | 15.1 | 15.6 | 10.8 | --- | 32.5 | 41.8 | 47.1 |

Exchangeable Calcium, me/100g

PLOT 35

| DATE | SITE | DEPTH (cm) | | | | | | |
|--------|------|------------|------|-------|------|-------|-------|--------|
| | | 0-3 | 0-15 | 15-30 | 0-30 | 30-60 | 60-90 | 90-120 |
| 800519 | 1 | --- | --- | --- | 15.4 | 42.3 | 42.8 | 35.4 |
| 800519 | 2 | --- | --- | --- | 12.5 | 13.4 | 42.1 | 32.5 |
| 800519 | 3 | --- | --- | --- | 24.1 | 48.4 | 47.3 | 47.6 |
| 801104 | 1 | --- | --- | --- | --- | 45.3 | 39.6 | --- |
| 801104 | 2 | --- | --- | --- | 42.2 | 62.6 | 69.5 | 44.9 |
| 801104 | 3 | --- | --- | --- | 15.1 | 47.1 | 55.2 | 52.0 |
| 820426 | 1 | --- | 14.9 | 17.4 | --- | --- | --- | --- |
| 820426 | 3 | --- | 13.5 | 14.5 | --- | --- | --- | --- |
| 820426 | 5 | --- | 15.7 | 15.2 | --- | --- | --- | --- |
| 820426 | 6 | --- | 12.9 | 14.9 | --- | --- | --- | --- |
| 820911 | 1 | 17.7 | 15.6 | 25.2 | --- | 43.3 | --- | --- |
| 820911 | 2 | 16.1 | 14.8 | 18.5 | --- | 49.2 | 46.9 | 45.0 |

Chemical soil analysis 1980-1982

| | | Exchangeable Calcium, me/100g | | | PLOT 35G | | | |
|--------|------|-------------------------------|------|-------|----------|-------|-------|--------|
| DATE | SITE | DEPTH (cm) | | | | | | |
| | | 0-3 | 0-15 | 15-30 | 0-30 | 30-60 | 60-90 | 90-120 |
| 800519 | 1 | --- | --- | --- | 34.3 | 29.9 | 31.3 | --- |
| 800519 | 2 | --- | --- | --- | 18.4 | 62.0 | 58.6 | 127.3 |
| 800519 | 3 | --- | --- | --- | 19.3 | 58.0 | 59.9 | --- |
| 801104 | 3 | --- | --- | --- | --- | --- | 22.4 | --- |
| 820426 | 1 | --- | 13.5 | 14.7 | --- | --- | --- | --- |
| 820426 | 3 | --- | 15.6 | 14.4 | --- | --- | --- | --- |
| 820426 | 4 | --- | 17.5 | 17.2 | --- | --- | --- | --- |
| 820426 | 5 | --- | 18.1 | 18.6 | --- | --- | --- | --- |
| 820911 | 1 | 22.0 | 17.1 | 19.6 | --- | 4.4 | 47.0 | 42.1 |
| 820911 | 2 | 20.1 | 19.9 | 24.1 | --- | 41.4 | 45.8 | 51.2 |

| | | Exchangeable Calcium, me/100g | | | PLOT 20 | | | |
|--------|------|-------------------------------|------|-------|---------|-------|-------|--------|
| DATE | SITE | DEPTH (cm) | | | | | | |
| | | 0-3 | 0-15 | 15-30 | 0-30 | 30-60 | 60-90 | 90-120 |
| 800519 | 1 | --- | --- | --- | 20.2 | 55.9 | 46.1 | 47.7 |
| 800519 | 2 | --- | --- | --- | 23.6 | 44.2 | 59.2 | --- |
| 800519 | 3 | --- | --- | --- | 18.7 | 19.0 | --- | --- |
| 801104 | 1 | --- | --- | --- | 39.5 | 48.0 | 36.3 | 39.9 |
| 801104 | 2 | --- | --- | --- | --- | --- | 44.5 | --- |
| 801104 | 3 | --- | --- | --- | --- | 42.0 | --- | --- |
| 820426 | 1 | --- | 15.2 | 15.2 | --- | --- | --- | --- |
| 820426 | 3 | --- | 11.9 | 14.8 | --- | --- | --- | --- |
| 820911 | 1 | 16.9 | 17.2 | 18.4 | --- | 46.3 | 43.9 | 46.4 |
| 820911 | 2 | 17.9 | 16.9 | 16.3 | --- | 44.4 | 47.8 | 42.2 |

EC of Sat Extract, uS/cm

PLOT 50

| DATE | SITE | DEPTH (cm) | | | | | | |
|--------|------|------------|------|-------|------|-------|-------|--------|
| | | 0-3 | 0-15 | 15-30 | 0-30 | 30-60 | 60-90 | 90-120 |
| 800519 | 1 | --- | --- | --- | 1291 | 1003 | 853 | 790 |
| 800519 | 2 | --- | --- | --- | 1229 | 827 | 853 | 940 |
| 800519 | 3 | --- | --- | --- | 1422 | 776 | 872 | 821 |
| 801104 | 1 | --- | --- | --- | 1782 | 1489 | 1349 | 1098 |
| 801104 | 2 | --- | --- | --- | 1782 | 1306 | 1440 | 1147 |
| 801104 | 3 | --- | --- | --- | 2075 | 1416 | 1233 | 1294 |
| 811009 | 1 | --- | --- | --- | 2097 | 2435 | 1823 | 2435 |
| 811009 | 2 | --- | --- | --- | 1575 | 1650 | 3358 | 1748 |
| 811009 | 3 | --- | --- | --- | 2102 | 2809 | 1650 | 2919 |
| 820426 | 1 | --- | 2016 | 2240 | --- | --- | --- | --- |
| 820426 | 2 | --- | 2240 | 2744 | --- | --- | --- | --- |
| 820426 | 3 | --- | 1736 | 1055 | --- | --- | --- | --- |
| 820426 | 4 | --- | 1497 | 1293 | --- | --- | --- | --- |
| 820426 | 5 | --- | 1542 | 1411 | --- | --- | --- | --- |
| 820426 | 6 | --- | 1815 | 1730 | --- | --- | --- | --- |
| 820911 | 1 | 2037 | 1652 | 1211 | --- | 1432 | 1211 | 1520 |
| 820911 | 2 | 2767 | 2019 | 2037 | --- | 2030 | 1927 | 1817 |

EC of Sat Extract, uS/cm

PLOT 20

| DATE | SITE | DEPTH (cm) | | | | | | |
|--------|------|------------|------|-------|------|-------|-------|--------|
| | | 0-3 | 0-15 | 15-30 | 0-30 | 30-60 | 60-90 | 90-120 |
| 800519 | 1 | --- | --- | --- | 785 | 617 | 492 | 2416 |
| 800519 | 2 | --- | --- | --- | 1379 | 804 | 5138 | --- |
| 800519 | 3 | --- | --- | --- | 716 | 1132 | --- | --- |
| 801104 | 1 | --- | --- | --- | 2148 | 1428 | 2288 | 3783 |
| 801104 | 2 | --- | --- | --- | --- | --- | 3204 | --- |
| 801104 | 3 | --- | --- | --- | --- | 1477 | --- | --- |
| 811009 | 1 | --- | --- | --- | 3179 | 3688 | 2098 | 1169 |
| 811009 | 2 | --- | --- | --- | 2988 | 3306 | 2416 | --- |
| 811009 | 3 | --- | --- | --- | 3306 | 4578 | --- | --- |
| 820426 | 1 | --- | 1804 | 1804 | --- | --- | --- | --- |
| 820426 | 2 | --- | 1775 | 1443 | --- | --- | --- | --- |
| 820426 | 3 | --- | 1513 | 2909 | --- | --- | --- | --- |
| 820426 | 4 | --- | 1804 | 2211 | --- | --- | --- | --- |
| 820911 | 1 | 562 | 980 | 694 | --- | 1652 | 1982 | 5286 |
| 820911 | 2 | 595 | 595 | 1057 | --- | 1652 | 3304 | 4626 |

EC of Sat Extract, uS/cm

PLOT 35G

| DATE | SITE | DEPTH (cm) | | | | | | |
|--------|------|------------|------|-------|------|-------|-------|--------|
| | | 0-3 | 0-15 | 15-30 | 0-30 | 30-60 | 60-90 | 90-120 |
| 800519 | 1 | --- | --- | --- | 1079 | 741 | 399 | --- |
| 800519 | 2 | --- | --- | --- | 1344 | 669 | 4027 | 8332 |
| 800519 | 3 | --- | --- | --- | 1277 | 556 | 1577 | --- |
| 801104 | 3 | --- | --- | --- | --- | --- | 1684 | --- |
| 811009 | 1 | --- | --- | --- | 3433 | 2990 | 3051 | 3306 |
| 811009 | 2 | --- | --- | --- | 3688 | 4451 | 2098 | 5023 |
| 811009 | 3 | --- | --- | --- | 4578 | 3306 | 3560 | 5099 |
| 820426 | 1 | --- | 2688 | 2128 | --- | --- | --- | --- |
| 820426 | 2 | --- | 2912 | 2408 | --- | --- | --- | --- |
| 820426 | 3 | --- | 3472 | 2800 | --- | --- | --- | --- |
| 820426 | 4 | --- | 2632 | 2240 | --- | --- | --- | --- |
| 820426 | 5 | --- | 3024 | 1848 | --- | --- | --- | --- |
| 820426 | 6 | --- | 1792 | 1523 | --- | --- | --- | --- |
| 820911 | 1 | 1432 | 1630 | 1410 | --- | 1652 | 2423 | 2643 |
| 820911 | 2 | 1253 | 1769 | 2200 | --- | 1656 | 2183 | 4367 |

EC of Sat Extract, uS/cm

PLOT 35

| DATE | SITE | DEPTH (cm) | | | | | | |
|--------|------|------------|------|-------|------|-------|-------|--------|
| | | 0-3 | 0-15 | 15-30 | 0-30 | 30-60 | 60-90 | 90-120 |
| 800519 | 1 | --- | --- | --- | 1329 | 1010 | 895 | 869 |
| 800519 | 2 | --- | --- | --- | 1344 | 984 | 933 | 882 |
| 800519 | 3 | --- | --- | --- | 2103 | 1203 | 535 | 368 |
| 801104 | 1 | --- | --- | --- | --- | 2209 | 1965 | --- |
| 801104 | 2 | --- | --- | --- | 1495 | 3753 | 4271 | 5004 |
| 801104 | 3 | --- | --- | --- | 1892 | 1324 | 4515 | 5370 |
| 811009 | 1 | --- | --- | --- | 3014 | 4393 | --- | --- |
| 811009 | 2 | --- | --- | --- | 2438 | 2480 | 2798 | 5086 |
| 811009 | 3 | --- | --- | --- | 2543 | 3306 | --- | --- |
| 820426 | 1 | --- | 1270 | 1316 | --- | --- | --- | --- |
| 820426 | 2 | --- | 1470 | 1327 | --- | --- | --- | --- |
| 820426 | 3 | --- | 1746 | 1117 | --- | --- | --- | --- |
| 820426 | 4 | --- | 1513 | 977 | --- | --- | --- | --- |
| 820426 | 5 | --- | 1629 | 1327 | --- | --- | --- | --- |
| 820426 | 6 | --- | 1804 | 1920 | --- | --- | --- | --- |
| 820911 | 1 | 826 | 1145 | 1338 | --- | 1586 | --- | --- |
| 820911 | 2 | 980 | 1652 | 1476 | --- | 1356 | 1927 | 2836 |

pH of Saturated Soil Paste

PLOT 50

| DATE | SITE | DEPTH (cm) | | | | | | |
|--------|------|------------|------|-------|------|-------|-------|--------|
| | | 0-3 | 0-15 | 15-30 | 0-30 | 30-60 | 60-90 | 90-120 |
| 800519 | 1 | --- | --- | --- | 6.9 | 7.7 | 8.1 | 8.1 |
| 800519 | 2 | --- | --- | --- | 6.6 | 7.4 | 8.0 | 8.1 |
| 800519 | 3 | --- | --- | --- | 7.5 | 8.2 | 8.1 | 8.1 |
| 801104 | 1 | --- | --- | --- | 7.0 | 7.6 | 7.8 | 7.8 |
| 801104 | 2 | --- | --- | --- | 6.9 | 7.5 | 7.6 | 7.7 |
| 801104 | 3 | --- | --- | --- | 6.8 | 7.5 | 7.7 | 7.8 |
| 811009 | 1 | --- | --- | --- | 7.1 | 7.5 | 8.0 | 7.7 |
| 811009 | 2 | --- | --- | --- | 7.2 | 7.4 | 7.3 | 7.7 |
| 811009 | 3 | --- | --- | --- | 7.3 | 7.5 | 7.8 | 7.8 |
| 820426 | 1 | --- | 6.3 | 6.3 | --- | --- | --- | --- |
| 820426 | 2 | --- | 6.8 | 7.3 | --- | --- | --- | --- |
| 820426 | 3 | --- | 7.0 | 6.7 | --- | --- | --- | --- |
| 820426 | 4 | --- | 7.3 | 6.8 | --- | --- | --- | --- |
| 820426 | 5 | --- | 6.6 | 6.7 | --- | --- | --- | --- |
| 820426 | 6 | --- | 6.4 | 6.2 | --- | --- | --- | --- |
| 820911 | 1 | 7.1 | 7.2 | 7.3 | --- | 7.6 | 7.8 | 7.8 |
| 820911 | 2 | 7.4 | 7.2 | 7.4 | --- | 7.7 | 8.1 | 7.9 |

pH of Saturated Soil Paste

PLOT 20

| DATE | SITE | DEPTH (cm) | | | | | | |
|--------|------|------------|------|-------|------|-------|-------|--------|
| | | 0-3 | 0-15 | 15-30 | 0-30 | 30-60 | 60-90 | 90-120 |
| 800519 | 1 | --- | --- | --- | 7.0 | 7.7 | 8.0 | 7.7 |
| 800519 | 2 | --- | --- | --- | 7.4 | 7.6 | 7.9 | --- |
| 800519 | 3 | --- | --- | --- | 6.5 | 6.6 | --- | --- |
| 801104 | 1 | --- | --- | --- | 7.5 | 7.8 | 7.5 | 8.0 |
| 801104 | 2 | --- | --- | --- | --- | --- | 7.3 | --- |
| 801104 | 3 | --- | --- | --- | --- | 7.4 | --- | --- |
| 811009 | 1 | --- | --- | --- | 7.6 | 8.0 | 7.9 | 8.0 |
| 811009 | 2 | --- | --- | --- | 7.0 | 7.8 | 7.8 | --- |
| 811009 | 3 | --- | --- | --- | 7.1 | 7.0 | --- | --- |
| 820426 | 1 | --- | 6.7 | 6.2 | --- | --- | --- | --- |
| 820426 | 2 | --- | 5.8 | 6.9 | --- | --- | --- | --- |
| 820426 | 3 | --- | 6.7 | 6.0 | --- | --- | --- | --- |
| 820426 | 4 | --- | 6.6 | 6.3 | --- | --- | --- | --- |
| 820911 | 1 | 6.8 | 7.2 | 7.4 | --- | 7.6 | 7.8 | 7.6 |
| 820911 | 2 | 7.4 | 7.4 | 7.3 | --- | 7.6 | 7.7 | 7.7 |

pH of Saturated Soil Paste

PLOT 35G

| DATE | SITE | DEPTH (cm) | | | | | | |
|--------|------|------------|------|-------|------|-------|-------|--------|
| | | 0-3 | 0-15 | 15-30 | 0-30 | 30-60 | 60-90 | 90-120 |
| 800519 | 1 | --- | --- | --- | 7.1 | 7.0 | 7.5 | --- |
| 800519 | 2 | --- | --- | --- | 6.9 | 7.5 | 8.3 | 7.9 |
| 800519 | 3 | --- | --- | --- | 6.9 | 7.4 | 7.9 | --- |
| 801104 | 3 | --- | --- | --- | --- | --- | 7.6 | --- |
| 811009 | 1 | --- | --- | --- | 7.3 | 7.4 | 7.6 | 7.8 |
| 811009 | 2 | --- | --- | --- | 7.3 | 7.6 | 7.7 | 7.7 |
| 811009 | 3 | --- | --- | --- | 6.8 | 7.2 | 7.6 | 7.8 |
| 820426 | 1 | --- | 6.6 | 6.0 | --- | --- | --- | --- |
| 820426 | 2 | --- | 6.6 | 6.0 | --- | --- | --- | --- |
| 820426 | 3 | --- | 6.6 | 6.3 | --- | --- | --- | --- |
| 820426 | 4 | --- | 6.4 | 5.8 | --- | --- | --- | --- |
| 820426 | 5 | --- | 6.9 | 7.0 | --- | --- | --- | --- |
| 820426 | 6 | --- | 7.2 | 6.4 | --- | --- | --- | --- |
| 820911 | 1 | 7.4 | 7.1 | 7.1 | --- | 7.6 | 7.7 | 7.8 |
| 820911 | 2 | 7.6 | 7.3 | 7.3 | --- | 7.8 | 7.6 | 7.7 |

pH of Saturated Soil Paste

PLOT 35

| DATE | SITE | DEPTH (cm) | | | | | | |
|--------|------|------------|------|-------|------|-------|-------|--------|
| | | 0-3 | 0-15 | 15-30 | 0-30 | 30-60 | 60-90 | 90-120 |
| 800519 | 1 | --- | --- | --- | 7.2 | 7.7 | 8.1 | 8.5 |
| 800519 | 2 | --- | --- | --- | 6.7 | 7.3 | 8.0 | 7.1 |
| 800519 | 3 | --- | --- | --- | 6.9 | 7.5 | 7.5 | 8.0 |
| 801104 | 1 | --- | --- | --- | --- | 7.6 | 7.5 | --- |
| 801104 | 2 | --- | --- | --- | 7.4 | 7.5 | 7.6 | 7.6 |
| 801104 | 3 | --- | --- | --- | 7.1 | 7.7 | 7.7 | 7.7 |
| 811009 | 1 | --- | --- | --- | 7.5 | 7.5 | --- | --- |
| 811009 | 2 | --- | --- | --- | 7.4 | 7.5 | 7.7 | 7.6 |
| 811009 | 3 | --- | --- | --- | 7.2 | 7.4 | --- | --- |
| 820426 | 1 | --- | 6.5 | 7.1 | --- | --- | --- | --- |
| 820426 | 2 | --- | 6.7 | 6.2 | --- | --- | --- | --- |
| 820426 | 3 | --- | 6.6 | 6.9 | --- | --- | --- | --- |
| 820426 | 4 | --- | 6.7 | 7.3 | --- | --- | --- | --- |
| 820426 | 5 | --- | 6.7 | 6.6 | --- | --- | --- | --- |
| 820426 | 6 | --- | 6.7 | 6.3 | --- | --- | --- | --- |
| 820911 | 1 | 7.6 | 7.3 | 7.5 | --- | 7.9 | --- | --- |
| 820911 | 2 | 7.5 | 7.1 | 7.4 | --- | 7.8 | 7.9 | 7.8 |

SAR of Soil Solution

PLOT 50

| DATE | SITE | DEPTH (cm) | | | | | | |
|--------|------|------------|------|-------|------|-------|-------|--------|
| | | 0-3 | 0-15 | 15-30 | 0-30 | 30-60 | 60-90 | 90-120 |
| 800519 | 1 | --- | --- | --- | 2.6 | 0.3 | 0.3 | 0.3 |
| 800519 | 2 | --- | --- | --- | 3.7 | 0.6 | 0.5 | 0.2 |
| 800519 | 3 | --- | --- | --- | 3.5 | 0.7 | 0.3 | 0.4 |
| 801104 | 1 | --- | --- | --- | 4.7 | 2.6 | 1.5 | 0.7 |
| 801104 | 2 | --- | --- | --- | 4.6 | 3.7 | 1.4 | 0.4 |
| 801104 | 3 | --- | --- | --- | 5.8 | 2.6 | 0.9 | 0.4 |
| 811009 | 1 | --- | --- | --- | 6.8 | 7.3 | 5.4 | 4.3 |
| 811009 | 2 | --- | --- | --- | 7.3 | 7.9 | 3.3 | 2.4 |
| 811009 | 3 | --- | --- | --- | 9.7 | 8.5 | 5.2 | 6.1 |
| 820426 | 1 | --- | 6.3 | 7.0 | --- | --- | --- | --- |
| 820426 | 2 | --- | 6.2 | 7.2 | --- | --- | --- | --- |
| 820426 | 3 | --- | 5.4 | 6.6 | --- | --- | --- | --- |
| 820426 | 4 | --- | 6.7 | 7.1 | --- | --- | --- | --- |
| 820426 | 5 | --- | 5.4 | 5.3 | --- | --- | --- | --- |
| 820426 | 6 | --- | 7.3 | 7.8 | --- | --- | --- | --- |
| 820911 | 1 | 4.6 | 4.9 | 5.9 | --- | 5.8 | 4.9 | 5.1 |
| 820911 | 2 | 6.6 | 6.4 | 7.6 | --- | 8.4 | 7.6 | 4.9 |

SAR of Soil Solution

PLOT 20

| DATE | SITE | DEPTH (cm) | | | | | | |
|--------|------|------------|------|-------|------|-------|-------|--------|
| | | 0-3 | 0-15 | 15-30 | 0-30 | 30-60 | 60-90 | 90-120 |
| 800519 | 1 | --- | --- | --- | 1.2 | 0.4 | 0.8 | 1.6 |
| 800519 | 2 | --- | --- | --- | 2.2 | 1.0 | 2.1 | --- |
| 800519 | 3 | --- | --- | --- | 0.7 | 1.9 | --- | --- |
| 801104 | 1 | --- | --- | --- | 3.5 | 0.3 | 0.8 | 2.5 |
| 801104 | 2 | --- | --- | --- | --- | --- | 1.0 | --- |
| 801104 | 3 | --- | --- | --- | --- | 0.5 | --- | --- |
| 811009 | 1 | --- | --- | --- | 5.9 | 2.6 | 0.8 | 2.2 |
| 811009 | 2 | --- | --- | --- | 6.8 | 1.4 | 1.9 | --- |
| 811009 | 3 | --- | --- | --- | 5.9 | 2.8 | --- | --- |
| 820426 | 1 | --- | 6.5 | 7.3 | --- | --- | --- | --- |
| 820426 | 2 | --- | 5.6 | 7.5 | --- | --- | --- | --- |
| 820426 | 3 | --- | 5.8 | 8.0 | --- | --- | --- | --- |
| 820426 | 4 | --- | 6.7 | 7.3 | --- | --- | --- | --- |
| 820911 | 1 | 2.1 | 7.8 | 5.0 | --- | 5.2 | 2.7 | 1.2 |
| 820911 | 2 | 2.4 | 4.6 | 7.4 | --- | 5.3 | 1.5 | 1.7 |

SAR of Soil Solution

PLOT 35G

| DATE | SITE | DEPTH(cm) | | | | | | |
|--------|------|-----------|------|-------|------|-------|-------|--------|
| | | 0-3 | 0-15 | 15-30 | 0-30 | 30-60 | 60-90 | 90-120 |
| 800519 | 1 | --- | --- | --- | 1.3 | 0.4 | 0.8 | --- |
| 800519 | 2 | --- | --- | --- | 1.5 | 0.3 | 0.7 | 2.4 |
| 800519 | 3 | --- | --- | --- | 1.9 | 0.4 | 1.6 | --- |
| 801104 | 3 | --- | --- | --- | --- | --- | 0.5 | --- |
| 811009 | 1 | --- | --- | --- | 5.9 | 6.9 | 3.2 | 1.0 |
| 811009 | 2 | --- | --- | --- | 6.7 | 6.0 | 5.8 | 1.0 |
| 811009 | 3 | --- | --- | --- | 7.8 | 4.0 | 1.5 | 0.8 |
| 820426 | 1 | --- | 5.0 | 6.7 | --- | --- | --- | --- |
| 820426 | 2 | --- | 5.7 | 6.8 | --- | --- | --- | --- |
| 820426 | 3 | --- | 5.9 | 7.6 | --- | --- | --- | --- |
| 820426 | 4 | --- | 5.9 | 6.8 | --- | --- | --- | --- |
| 820426 | 5 | --- | 4.2 | 6.2 | --- | --- | --- | --- |
| 820426 | 6 | --- | 5.4 | 5.6 | --- | --- | --- | --- |
| 820911 | 1 | 3.9 | 4.4 | 4.9 | --- | 5.6 | 4.6 | 3.5 |
| 820911 | 2 | 4.0 | 4.9 | 6.7 | --- | 6.6 | 4.5 | 2.9 |

SAR of Soil Solution

PLOT 35

| DATE | SITE | DEPTH(cm) | | | | | | |
|--------|------|-----------|------|-------|------|-------|-------|--------|
| | | 0-3 | 0-15 | 15-30 | 0-30 | 30-60 | 60-90 | 90-120 |
| 800519 | 1 | --- | --- | --- | 3.1 | 0.7 | 0.3 | 0.4 |
| 800519 | 2 | --- | --- | --- | 2.6 | 0.4 | 0.4 | 0.4 |
| 800519 | 3 | --- | --- | --- | 1.4 | 0.3 | 0.4 | 0.7 |
| 801104 | 1 | --- | --- | --- | --- | 2.1 | 0.9 | --- |
| 801104 | 2 | --- | --- | --- | 4.1 | 0.7 | 0.9 | 1.7 |
| 801104 | 3 | --- | --- | --- | 4.5 | 1.0 | 1.0 | 1.6 |
| 811009 | 1 | --- | --- | --- | 8.4 | 8.6 | --- | --- |
| 811009 | 2 | --- | --- | --- | 6.9 | 5.3 | 2.7 | 0.8 |
| 811009 | 3 | --- | --- | --- | 8.1 | 5.3 | --- | --- |
| 820426 | 1 | --- | 5.6 | 7.4 | --- | --- | --- | --- |
| 820426 | 2 | --- | 6.8 | 7.8 | --- | --- | --- | --- |
| 820426 | 3 | --- | 4.9 | 5.7 | --- | --- | --- | --- |
| 820426 | 4 | --- | 5.7 | 4.8 | --- | --- | --- | --- |
| 820426 | 5 | --- | 6.4 | 6.9 | --- | --- | --- | --- |
| 820426 | 6 | --- | 6.5 | 7.6 | --- | --- | --- | --- |
| 820911 | 1 | 3.1 | 4.6 | 6.9 | --- | 8.3 | --- | --- |
| 820911 | 2 | 4.1 | 6.2 | 7.2 | --- | 7.1 | 4.9 | 2.3 |

Chemical soil analysis 1980-1982

Cation Exch Capacity(CEC),me/100g

PLOT 20G

| DATE | SITE | DEPTH(cm) | | | | | | |
|--------|------|-----------|------|-------|------|-------|-------|--------|
| | | 0-3 | 0-15 | 15-30 | 0-30 | 30-60 | 60-90 | 90-120 |
| 820426 | 1 | --- | 23.4 | 18.6 | --- | --- | --- | --- |
| 820426 | 2 | --- | 21.6 | 19.6 | --- | --- | --- | --- |
| 820911 | 1 | 24.5 | 22.4 | 22.9 | --- | 15.1 | 14.7 | 18.2 |
| 820911 | 2 | 24.6 | 22.4 | 22.9 | --- | 15.1 | 14.7 | 18.2 |

Exchangeable Sodium,me/100g

PLOT 20G

| DATE | SITE | DEPTH(cm) | | | | | | |
|--------|------|-----------|------|-------|------|-------|-------|--------|
| | | 0-3 | 0-15 | 15-30 | 0-30 | 30-60 | 60-90 | 90-120 |
| 820426 | 1 | --- | 1.7 | 2.1 | --- | --- | --- | --- |
| 820426 | 2 | --- | 2.3 | 1.9 | --- | --- | --- | --- |
| 820911 | 1 | 0.8 | 1.3 | 1.7 | --- | 1.2 | 1.3 | 1.0 |
| 820911 | 2 | 0.8 | 1.5 | 2.8 | --- | 1.7 | 0.7 | 1.0 |

Exchangeable Magnesium, me/100g

PLOT 20G

| DATE | SITE | DEPTH(cm) | | | | | | |
|--------|------|-----------|------|-------|------|-------|-------|--------|
| | | 0-3 | 0-15 | 15-30 | 0-30 | 30-60 | 60-90 | 90-120 |
| 820426 | 1 | --- | 5.4 | 4.5 | --- | --- | --- | --- |
| 820426 | 2 | --- | 5.5 | 3.5 | --- | --- | --- | --- |
| 820911 | 1 | 5.1 | 2.9 | 4.9 | --- | 4.9 | 7.2 | 14.9 |
| 820911 | 2 | 3.9 | 4.5 | 4.6 | --- | 6.6 | 11.9 | 14.2 |

Exchangeable Calcium, me/100g

PLOT 20G

| DATE | SITE | DEPTH(cm) | | | | | | |
|--------|------|-----------|------|-------|------|-------|-------|--------|
| | | 0-3 | 0-15 | 15-30 | 0-30 | 30-60 | 60-90 | 90-120 |
| 820426 | 1 | --- | 17.2 | 19.0 | --- | --- | --- | --- |
| 820426 | 2 | --- | 14.6 | 13.4 | --- | --- | --- | --- |
| 820911 | 1 | 23.7 | 12.7 | 15.7 | --- | 42.3 | 40.4 | 37.1 |
| 820911 | 2 | 20.3 | 18.1 | 16.5 | --- | 42.8 | 48.5 | 45.0 |

Chemical soil analysis 1980-1982

| | | EC of Sat Extract, uS/cm | | | | PLOT 20G | | | |
|--------|------|--------------------------|--------|--------|------|----------|--------|--------|--|
| DATE | SITE | DEPTH(cm) | | | | | | | |
| | | 0-3 | 0-15 | 15-30 | 0-30 | 30-60 | 60-90 | 90-120 | |
| 820426 | 1 | --- | 1676.0 | 1303.0 | --- | --- | --- | --- | |
| 820426 | 2 | --- | 1222.0 | 1684.0 | --- | --- | --- | --- | |
| 820911 | 1 | 1586.0 | 1432.0 | 1211.0 | --- | 1762.0 | 1735.0 | 1927.0 | |
| 820911 | 2 | 2093.0 | 1520.0 | 1927.0 | --- | 2753.0 | 3634.0 | 6718.0 | |

| | | pH of Saturated Soil Paste | | | | PLOT 20G | | | |
|--------|------|----------------------------|------|-------|------|----------|-------|--------|--|
| DATE | SITE | DEPTH(cm) | | | | | | | |
| | | 0-3 | 0-15 | 15-30 | 0-30 | 30-60 | 60-90 | 90-120 | |
| 820426 | 1 | --- | 7.0 | 6.4 | --- | --- | --- | --- | |
| 820426 | 2 | --- | 6.9 | 6.3 | --- | --- | --- | --- | |
| 820911 | 1 | 7.1 | 6.9 | 6.9 | --- | 6.9 | 7.7 | 7.8 | |
| 820911 | 2 | 7.3 | 7.1 | 7.0 | --- | 7.6 | 7.7 | 7.8 | |

| | | SAR of Soil Solution | | | | PLOT 20G | | | |
|--------|------|----------------------|------|-------|------|----------|-------|--------|--|
| DATE | SITE | DEPTH(cm) | | | | | | | |
| | | 0-3 | 0-15 | 15-30 | 0-30 | 30-60 | 60-90 | 90-120 | |
| 820426 | 1 | --- | 5.4 | 7.6 | --- | --- | --- | --- | |
| 820426 | 2 | --- | 7.2 | 7.7 | --- | --- | --- | --- | |
| 820911 | 1 | 1.7 | 2.9 | 4.7 | --- | 4.5 | 4.2 | 1.8 | |
| 820911 | 2 | 2.5 | 4.4 | 7.7 | --- | 4.5 | 1.0 | 2.1 | |

| | | Exchangeable Sodium Percentage ESP | | | | PLOT 20G | | | |
|--------|------|------------------------------------|------|-------|------|----------|-------|--------|--|
| DATE | SITE | DEPTH(cm) | | | | | | | |
| | | 0-3 | 0-15 | 15-30 | 0-30 | 30-60 | 60-90 | 90-120 | |
| 820426 | 1 | --- | 7.1 | 11.1 | --- | --- | --- | --- | |
| 820426 | 2 | --- | 10.5 | 9.8 | --- | --- | --- | --- | |
| 820911 | 1 | 3.2 | 5.6 | 7.3 | --- | 8.1 | 8.8 | 5.2 | |
| 820911 | 2 | 3.0 | 6.6 | 12.3 | --- | 11.0 | 4.6 | 5.7 | |

Appendix E. James River water quality data 1980-1982. This river supplies the town of Huron with water. (Taken from U.S.G.S. Water Quality Records 1979-1982.)

JAMES RIVER WATER QUALITY 1980-1982

| DATE | EC uS/cm | Ca ppm | Mg ppm | %Na | SAR | Alk(T) as CaCO3 | SO4 ppm | Cl ppm | NO3+NO2 as N ppm | Tot PO4 ppm |
|--------|-------------|-----------|-----------|------|-----|--------------------|------------|-----------|---------------------|----------------|
| 800331 | 830 | 68 | 30 | 31.0 | 1.6 | 220 | 180 | 25 | 0.01 | 0.16 |
| 800430 | 710 | 57 | 26 | 35.0 | 1.8 | 160 | 170 | 40 | 0.02 | 0.20 |
| 800528 | 970 | 78 | 38 | 32.0 | 1.8 | 270 | 190 | 39 | 0.04 | 0.28 |
| 800701 | 940 | 69 | 33 | 33.0 | 1.8 | 230 | 210 | 43 | 0.12 | 0.20 |
| 801229 | 1720 | 92 | 64 | 43.0 | 3.5 | 340 | 380 | 120 | 0.06 | 0.18 |
| 810123 | 1480 | 120 | 66 | 40.0 | 3.3 | 400 | 390 | 110 | 0.00 | 0.12 |
| 810224 | 1320 | 76 | 42 | 45.0 | 3.2 | 250 | 280 | 110 | 0.00 | 0.11 |
| 810323 | 1540 | 92 | 51 | 42.0 | 3.1 | 300 | 320 | 110 | 0.00 | 0.15 |
| 810504 | 1560 | 95 | 57 | 43.0 | 3.4 | 330 | 400 | 96 | 0.00 | 0.30 |
| 810803 | 1320 | 79 | 56 | 46.0 | 4.3 | 320 | 350 | 110 | 0.23 | 0.69 |
| 820226 | 700 | 52 | 27 | 37.0 | 2.2 | 160 | 180 | 38 | 1.30 | 0.55 |
| 820518 | 690 | 50 | 23 | 35.0 | 1.9 | 210 | 110 | 30 | 0.00 | 0.46 |
| 820611 | 690 | 53 | 25 | 33.0 | 1.7 | 222 | 100 | 26 | 0.00 | 0.32 |
| 820727 | 890 | 65 | 33 | 35.0 | 2.2 | 322 | 130 | 36 | 0.00 | 0.26 |
| 820903 | 966 | 70 | 38 | 36.0 | 2.4 | 302 | 160 | 50 | 0.56 | 0.21 |
| 820930 | 970 | 74 | 38 | 36.0 | 2.4 | 332 | 150 | 36 | 0.00 | 0.31 |
| 821101 | 960 | 62 | 35 | 37.0 | 2.4 | 290 | 180 | 33 | 0.15 | 0.21 |

Appendix F. Secondary-treated municipal effluent water quality at Huron 1980-1982. Samples were taken from the irrigation nozzles as the water was pumped from the last stage of the lagoon.

Electrical Conductivity
Sodium Adsorption Ratio
Adjusted Sodium Adsorption Ratio
Calcium
Magnesium
Sodium
Potassium
Chloride
Sulfate
Bicarbonate
Carbonate
Nitrate
Total Kjeldahl Nitrogen
Total Phosphate
pH

Huron's Secondary-Treated Effluent Water Quality 1980-1982

| DATE | EC uS/cm | SAR* | ASAR+ | Ca ppm | Mg ppm | Na ppm | K ppm | Cl ppm | SO4 ppm | HCO3 ppm | CO3 ppm | NO3N ppm | TKN ppm | T-PO4 ppm | pH |
|--------|-------------|------|-------|-----------|-----------|-----------|----------|-----------|------------|-------------|------------|-------------|------------|--------------|-----|
| 800513 | 1543 | 5.0 | 13.2 | 88 | 38 | 222 | 24 | 220 | 210 | 473 | 14 | 0.3 | 24.4 | 5.2 | 8.2 |
| 800523 | 1880 | 5.1 | 13.5 | 97 | 52 | 249 | 31 | 255 | 250 | 546 | 0 | 0.1 | 23.0 | 6.3 | 7.5 |
| 800710 | 1753 | 5.4 | 13.5 | 61 | 56 | 243 | 38 | 265 | 257 | 250 | 91 | 0.2 | 4.5 | 0.5 | 8.4 |
| 800722 | 1974 | 5.5 | 13.1 | 63 | 48 | 235 | 40 | 285 | 270 | 227 | 67 | 0.1 | 3.4 | 1.1 | 9.2 |
| 800731 | 2129 | 6.2 | 15.2 | 92 | 41 | 283 | 39 | 320 | 292 | 264 | 58 | 0.1 | 5.0 | 1.2 | 8.8 |
| 800813 | 2183 | 6.1 | 15.4 | 96 | 50 | 295 | 42 | 300 | 315 | 249 | 77 | 0.1 | 3.7 | 1.3 | 8.9 |
| 800911 | 2300 | 6.1 | 15.5 | 92 | 68 | 315 | 37 | 308 | 370 | 342 | 34 | 0.1 | 6.1 | 1.3 | 8.3 |
| 800925 | 2400 | 6.1 | 15.5 | 100 | 60 | 313 | 39 | 312 | 325 | 365 | 23 | 0.1 | 3.4 | 0.9 | 8.3 |
| 800930 | 2250 | 5.9 | 15.0 | 102 | 61 | 306 | 36 | 305 | 395 | 398 | 0 | 0.1 | 5.1 | 1.8 | 8.2 |
| 801007 | 2600 | 5.2 | 13.4 | 88 | 77 | 278 | 42 | 320 | 415 | 288 | 53 | 6.5 | 8.6 | 1.2 | 8.4 |
| 810430 | 1916 | 5.8 | 14.9 | 96 | 72 | 305 | 42 | 350 | 425 | 274 | 72 | 1.1 | 3.3 | 2.8 | 8.8 |
| 810519 | 2300 | 6.0 | 15.3 | 136 | 48 | 321 | 45 | 388 | 475 | 378 | 0 | 0.2 | 10.4 | 1.6 | 8.1 |
| 810501 | 2800 | 6.4 | 16.6 | 112 | 58 | 334 | 45 | 380 | 404 | 464 | 0 | 0.7 | 12.9 | 3.6 | 7.5 |
| 810612 | 2700 | 6.9 | 18.2 | 112 | 62 | 366 | 48 | 390 | 500 | 500 | 0 | 0.1 | 15.8 | 3.1 | 7.5 |
| 810619 | 2396 | 8.1 | 21.1 | 109 | 65 | 430 | 46 | 405 | 530 | 488 | 0 | 0.2 | 16.8 | 2.2 | 7.5 |
| 810701 | 2150 | 8.0 | 19.6 | 112 | 48 | 400 | 44 | 415 | 624 | 366 | 0 | 4.5 | 6.4 | 1.1 | 8.0 |
| 810706 | 2500 | 8.3 | 18.0 | 88 | 62 | 415 | 38 | 415 | 550 | 195 | 0 | 0.4 | 4.2 | 1.9 | 7.4 |
| 810714 | 2600 | 8.4 | 20.7 | 112 | 43 | 410 | 41 | 425 | 620 | 354 | 24 | 0.1 | 6.6 | 1.2 | 8.3 |
| 810721 | 2500 | 7.9 | 19.6 | 112 | 62 | 420 | 42 | 445 | 600 | 305 | 24 | 0.2 | 7.2 | 1.2 | 8.5 |
| 810811 | 2748 | 11.7 | 28.2 | 104 | 43 | 560 | 39 | 450 | 640 | 390 | 0 | 0.2 | 9.3 | 1.6 | 8.1 |
| 810818 | 2900 | 9.2 | 22.9 | 112 | 46 | 460 | 36 | 440 | 570 | 403 | 0 | 0.2 | 6.7 | 1.5 | 8.2 |
| 810903 | 2900 | 10.6 | 25.3 | 96 | 48 | 510 | 44 | 430 | 570 | 356 | 0 | 0.1 | 7.4 | 1.2 | 8.0 |
| 810917 | 3000 | 8.5 | 21.1 | 96 | 72 | 450 | 52 | 530 | 506 | 366 | 0 | 0.2 | 6.3 | 0.9 | 8.0 |
| 811008 | 2800 | 9.7 | 22.4 | 128 | 31 | 470 | 49 | 490 | 530 | 293 | 0 | 0.0 | 7.7 | 0.6 | 7.8 |

Huron's Secondary-Treated Effluent Water Quality 1980-1982

| DATE | EC uS/cm | SAR* | ASAR+ | Ca ppm | Mg ppm | Na ppm | K ppm | Cl ppm | SO4 ppm | HCO3 ppm | CO3 ppm | NO3N ppm | TKN ppm | T-PO4 ppm | pH |
|--------|-------------|------|-------|-----------|-----------|-----------|----------|-----------|------------|-------------|------------|-------------|------------|--------------|-----|
| 820603 | 2050 | 5.6 | 14.1 | 98 | 43 | 265 | 29 | 270 | 369 | 425 | 0 | 0.2 | 23.8 | 5.1 | 7.8 |
| 820524 | 2000 | 4.5 | 11.0 | 104 | 58 | 229 | 34 | 270 | 344 | 295 | 14 | 1.0 | 8.4 | 0.3 | 8.3 |
| 820630 | 2150 | 5.1 | 12.4 | 96 | 58 | 254 | 32 | 272 | 344 | 332 | 0 | 1.1 | 8.3 | 2.3 | 7.9 |
| 820707 | 2100 | 6.4 | 15.6 | 90 | 48 | 303 | 36 | 280 | 365 | 361 | 0 | 2.6 | 3.7 | 4.3 | 7.6 |
| 820723 | 2100 | 6.4 | 15.3 | 81 | 43 | 285 | 34 | 300 | 350 | 371 | 0 | 0.1 | 8.6 | 3.7 | 7.8 |
| 820804 | 2256 | 5.6 | 13.4 | 101 | 55 | 282 | 39 | 280 | 357 | 220 | 36 | 10.5 | 6.2 | 3.4 | 8.6 |
| 820810 | 2453 | 5.8 | 14.0 | 86 | 53 | 276 | 49 | 245 | 375 | 329 | 12 | 3.7 | 3.8 | 3.0 | 8.4 |
| 820820 | 2048 | 5.5 | 14.0 | 96 | 67 | 287 | 13 | 292 | 425 | 342 | 24 | 11.5 | 9.3 | 1.5 | 8.4 |
| 820826 | 2050 | 5.5 | 13.7 | 103 | 58 | 282 | 22 | 265 | 469 | 354 | 0 | 12.4 | 17.6 | 3.8 | 8.5 |
| 820907 | 2400 | 6.5 | 16.3 | 111 | 63 | 344 | 39 | 310 | 500 | 315 | 30 | 8.0 | 3.1 | 5.6 | 8.6 |

*=Sodium Adsorption Ratio

+ = Adjusted Sodium Adsorption Ratio

T-PO4 = Total Phosphates as P

NO3N = Nitrates as Nitrogen

Appendix G. Plot observation well water quality data 1981-1982.

Electrical Conductivity

Sodium

Chloride

Bicarbonate

Nitrate

NH₃

Total Phosphate

pH

PLOT OBSERVATION WELL WATER QUALITY 1981-1982

PLOT 20

| DATE | EC uS/cm | SAR* | ASAR+ | Ca ppm | Mg ppm | Na ppm | K ppm | Cl ppm | SO4 ppm | HCO3 ppm | CO3 ppm | NO3N ppm | NH3 ppm | T-PO4 ppm | pH |
|--------|-------------|------|-------|-----------|-----------|-----------|----------|-----------|------------|-------------|------------|-------------|------------|--------------|-----|
| 801104 | 3100 | 0.0 | 0.0 | 0 | 0 | 206 | 0 | 82 | 0 | 64 | 0 | 0.0 | 1.4 | 0.0 | 7.7 |
| 810527 | 3300 | 1.8 | 5.4 | 440 | 204 | 180 | 26 | 90 | 2085 | 395 | 0 | 0.0 | 0.0 | 0.1 | 7.8 |
| 810604 | 3900 | 1.5 | 4.8 | 560 | 204 | 163 | 25 | 100 | 2070 | 532 | 0 | 0.0 | 0.0 | 0.0 | 7.5 |
| 810629 | 3300 | 0.0 | 0.0 | 0 | 0 | 184 | 0 | 210 | 0 | 525 | 0 | 0.1 | 2.0 | 0.0 | 7.4 |
| 810715 | 3500 | 0.0 | 0.0 | 0 | 0 | 227 | 0 | 112 | 0 | 525 | 0 | 0.1 | 2.0 | 0.1 | 7.6 |
| 810805 | 4000 | 0.0 | 0.0 | 0 | 0 | 173 | 0 | 110 | 0 | 525 | 0 | 0.1 | 3.0 | 0.2 | 7.6 |
| 810812 | 3800 | 0.0 | 0.0 | 0 | 0 | 180 | 0 | 75 | 0 | 525 | 0 | 0.1 | 2.6 | 0.1 | 7.8 |
| 810819 | 3900 | 0.0 | 0.0 | 0 | 0 | 194 | 0 | 69 | 0 | 561 | 0 | 0.1 | 2.6 | 0.0 | 7.2 |
| 810917 | 3900 | 0.0 | 0.0 | 0 | 0 | 186 | 0 | --- | 0 | 425 | 0 | 0.0 | 2.2 | 0.0 | 7.6 |
| 811007 | 3300 | 0.0 | 0.0 | 0 | 0 | 156 | 0 | 115 | 0 | 476 | 0 | 0.1 | 3.2 | 0.1 | 7.4 |
| 820503 | 3500 | 0.0 | 0.0 | 0 | 0 | 152 | 0 | 61 | 0 | 761 | 0 | 0.1 | 13.5 | 1.5 | 7.7 |
| 820825 | 3000 | 2.3 | 7.2 | 480 | 162 | 230 | 0 | 80 | 2035 | 488 | 0 | 0.7 | 30.0 | 0.1 | 8.0 |

PLOT 50

| DATE | EC uS/cm | SAR* | ASAR+ | Ca ppm | Mg ppm | Na ppm | K ppm | Cl ppm | SO4 ppm | HCO3 ppm | CO3 ppm | NO3N ppm | NH3 ppm | T-PO4 ppm | pH |
|--------|-------------|------|-------|-----------|-----------|-----------|----------|-----------|------------|-------------|------------|-------------|------------|--------------|-----|
| 801104 | 3100 | 0.0 | 0.0 | 0 | 0 | 123 | 0 | 10 | 0 | 364 | 56 | 7.2 | 0.0 | 0.0 | 8.2 |
| 810527 | 3300 | 1.0 | 3.0 | 376 | 432 | 119 | 8 | 142 | 2600 | 283 | 0 | 0.0 | 0.0 | 0.1 | 7.8 |
| 810604 | 3400 | 1.1 | 3.3 | 340 | 360 | 125 | 14 | 165 | 2420 | 295 | 0 | 0.0 | 0.0 | 0.3 | 7.4 |
| 810715 | 3600 | 0.0 | 0.0 | 0 | 0 | 98 | 0 | 95 | 0 | 317 | 0 | 0.3 | 0.6 | 0.1 | 7.8 |
| 810805 | 4200 | 0.0 | 0.0 | 0 | 0 | 90 | 0 | 43 | 0 | 336 | 0 | 0.2 | 1.2 | 0.1 | 7.5 |
| 810812 | 4300 | 0.0 | 0.0 | 0 | 0 | 112 | 0 | 470 | 0 | 281 | 0 | 0.2 | 1.5 | 0.0 | 7.7 |
| 810917 | 4100 | 0.0 | 0.0 | 0 | 0 | 75 | 0 | 0 | 0 | 281 | 22 | 0.1 | 0.4 | 0.9 | 8.2 |
| 811007 | 4500 | 0.0 | 0.0 | 0 | 0 | 151 | 0 | 120 | 0 | 305 | 0 | 0.2 | 0.6 | 0.0 | 7.8 |
| 820503 | 3500 | 0.0 | 0.0 | 0 | 0 | 70 | 0 | 235 | 0 | 266 | 0 | 0.3 | 1.4 | 0.1 | 7.8 |
| 820630 | 3700 | 0.0 | 0.0 | 0 | 0 | 80 | 0 | 20 | 0 | 222 | 0 | 0.5 | 0.0 | 0.2 | 7.7 |
| 820825 | 3500 | 1.0 | 2.9 | 360 | 504 | 125 | 0 | 410 | 2370 | 195 | 0 | 1.3 | 0.4 | 0.0 | 8.4 |

PLOT 35G

| DATE | EC uS/cm | SAR* | ASAR+ | Ca ppm | Mg ppm | Na ppm | K ppm | Cl ppm | SO4 ppm | HCO3 ppm | CO3 ppm | NO3N ppm | NH3 ppm | T-PO4 ppm | pH |
|--------|-------------|------|-------|-----------|-----------|-----------|----------|-----------|------------|-------------|------------|-------------|------------|--------------|-----|
| 801104 | 9700 | 0.0 | 0.0 | 0 | 0 | 670 | 0 | 312 | 0 | 120 | 20 | 4.0 | 0.0 | 0.0 | 8.2 |
| 810527 | 8500 | 2.1 | 7.0 | 470 | 1674 | 423 | 32 | 290 | 9000 | 405 | 0 | 3.0 | 0.0 | 0.1 | 7.7 |
| 810604 | 9900 | 2.7 | 9.1 | 540 | 1644 | 550 | 31 | 295 | 17350 | 405 | 0 | 2.0 | 0.0 | 0.0 | 7.3 |
| 810629 | 10500 | 0.0 | 0.0 | 0 | 0 | 860 | 0 | 610 | 0 | 449 | 0 | 7.1 | 0.0 | 0.0 | 7.1 |
| 810715 | 12200 | 0.0 | 0.0 | 0 | 0 | 780 | 0 | 300 | 0 | 464 | 0 | 3.3 | 0.2 | 0.2 | 7.1 |
| 810805 | 12200 | 0.0 | 0.0 | 0 | 0 | 467 | 0 | 340 | 0 | 482 | 0 | 4.6 | 0.0 | 0.0 | 7.3 |
| 810812 | 12200 | 0.0 | 0.0 | 0 | 0 | 790 | 0 | 380 | 0 | 390 | 78 | 4.1 | 0.2 | 0.0 | 8.2 |
| 810819 | 12900 | 0.0 | 0.0 | 0 | 0 | 890 | 0 | 425 | 0 | 598 | 0 | 3.7 | 0.2 | 0.1 | 7.2 |
| 810917 | 12267 | 0.0 | 0.0 | 0 | 0 | 1040 | 0 | 0 | 0 | 351 | 91 | 3.3 | 0.1 | 0.2 | 8.5 |
| 811007 | 11600 | 0.0 | 0.0 | 0 | 0 | 760 | 0 | 412 | 0 | 390 | 84 | 4.7 | 0.1 | 0.0 | 8.3 |
| 820603 | 10100 | 0.0 | 0.0 | 0 | 0 | 600 | 0 | 292 | 0 | 481 | 0 | 0.1 | 3.0 | 0.2 | 7.7 |
| 820825 | 8500 | 2.5 | 8.3 | 500 | 1944 | 550 | 0 | 450 | 9675 | 244 | 24 | 2.8 | 0.0 | 0.1 | 8.4 |

PLOT 35

| DATE | EC uS/cm | SAR* | ASAR+ | Ca ppm | Mg ppm | Na ppm | K ppm | Cl ppm | SO4 ppm | HCO3 ppm | CO3 ppm | NO3N ppm | NH3 ppm | T-PO4 ppm | pH |
|--------|-------------|------|-------|-----------|-----------|-----------|----------|-----------|------------|-------------|------------|-------------|------------|--------------|-----|
| 801104 | 4500 | 0.0 | 0.0 | 0 | 0 | 211 | 0 | 25 | 0 | 240 | 0 | 2.3 | 0.0 | 0.0 | 7.7 |
| 810527 | 4000 | 1.8 | 5.4 | 440 | 450 | 220 | 13 | 160 | 3000 | 303 | 22 | 4.0 | 0.0 | 0.2 | 8.2 |
| 810604 | 4400 | 2.0 | 6.2 | 700 | 318 | 255 | 19 | 165 | 2850 | 354 | 0 | 5.0 | 0.0 | 0.2 | 7.7 |
| 810629 | 4600 | 0.0 | 0.0 | 0 | 0 | 195 | 0 | 240 | 0 | 346 | 0 | 7.4 | 0.0 | 0.0 | 7.3 |
| 810715 | 4500 | 0.0 | 0.0 | 0 | 0 | 354 | 0 | 115 | 0 | 329 | 0 | 7.4 | 0.4 | 0.0 | 7.3 |
| 810805 | 5300 | 0.0 | 0.0 | 0 | 0 | 206 | 0 | 190 | 0 | 366 | 0 | 10.1 | 0.0 | 0.0 | 7.6 |
| 810812 | 5200 | 0.0 | 0.0 | 0 | 0 | 198 | 0 | 102 | 0 | 268 | 0 | 9.0 | 0.0 | 0.0 | 7.8 |
| 810819 | 5200 | 0.0 | 0.0 | 0 | 0 | 169 | 0 | 106 | 0 | 366 | 0 | 6.4 | 0.2 | 0.0 | 7.4 |
| 810917 | 4870 | 0.0 | 0.0 | 0 | 0 | 180 | 0 | 0 | 0 | 278 | 10 | 9.3 | 0.0 | 0.0 | 8.2 |
| 811007 | 4700 | 0.0 | 0.0 | 0 | 0 | 223 | 0 | 155 | 0 | 293 | 12 | 9.6 | 0.0 | 0.0 | 8.1 |
| 820603 | 4700 | 0.0 | 0.0 | 0 | 0 | 162 | 0 | 945 | 0 | 307 | 0 | 9.6 | 0.0 | 0.0 | 7.9 |
| 820825 | 3800 | 1.2 | 3.4 | 720 | 504 | 168 | 0 | 100 | 4120 | 195 | 0 | 7.2 | 0.0 | 0.1 | 8.3 |

Appendix H. Dry matter yields of alfalfa by treatment, replication, year, and cutting.

Table H1. Yield of alfalfa plots 1980 kg/ha (tons/acre) dry matter.

| Treatment | Site | Cuttings | | | | | | | |
|-------------|------|----------|--------|------|--------|------|--------|---|--------|
| | | 1 | | 2 | | 3 | | 4 | |
| Plot 50 | 1 | 3212 | (1.43) | 1565 | (0.67) | 2381 | (1.00) | - | (--) |
| | 2 | 2514 | (1.03) | 896 | (0.31) | 2718 | (1.21) | - | (--) |
| | 3 | 1932 | (0.88) | 1797 | (0.80) | 2965 | (1.32) | - | (--) |
| Plot 35G | 1 | 2651 | (1.10) | 1752 | (0.78) | 3055 | (1.36) | - | (--) |
| | 2 | 2471 | (1.10) | 1664 | (0.69) | 2943 | (1.31) | - | (--) |
| | 3 | 2449 | (1.09) | 2224 | (0.99) | 2920 | (1.30) | - | (--) |
| Plot 35 | 1 | 2536 | (1.04) | 1730 | (0.77) | 2583 | (1.15) | - | (--) |
| | 2 | 2426 | (1.08) | 1640 | (0.73) | 2516 | (1.12) | - | (--) |
| | 3 | 2561 | (1.14) | 1483 | (0.66) | 2808 | (1.25) | - | (--) |
| Plot 20 | 1 | 1932 | (0.86) | 1864 | (0.83) | 2673 | (1.19) | - | (--) |
| | 2 | 1820 | (0.81) | 1662 | (0.74) | 2718 | (1.21) | - | (--) |
| | 3 | 2022 | (0.90) | 2201 | (0.96) | 2291 | (1.02) | - | (--) |
| 20 (gypsum) | 1 | - | (--) | - | (--) | - | (--) | - | (--) |
| | 2 | - | (--) | - | (--) | - | (--) | - | (--) |
| | 3 | - | (--) | - | (--) | - | (--) | - | (--) |
| Check | 1 | 674 | (0.30) | 1011 | (0.45) | 651 | (0.29) | - | (--) |
| | 2 | 741 | (0.33) | 1909 | (0.85) | 1280 | (0.57) | - | (--) |
| | 3 | 2224 | (0.99) | 1303 | (0.58) | 1258 | (0.56) | - | (--) |

Table H2. Yield of alfalfa plots 1981 kg/ha (tons/acre) dry matter.

| Treatment | Site | Cuttings | | | | | | | |
|-------------|------|----------|--------|------|--------|------|--------|------|--------|
| | | 1 | | 2 | | 3 | | 4 | |
| Plot 50 | 1 | 2988 | (1.33) | 2920 | (1.30) | 3145 | (1.40) | 1932 | (0.85) |
| | 2 | 2936 | (1.29) | 2965 | (1.32) | 2471 | (1.10) | 1864 | (0.83) |
| | 3 | 3122 | (1.39) | 3437 | (1.53) | 2765 | (1.24) | 1775 | (0.79) |
| Plot 35G | 1 | 1730 | (0.77) | 3325 | (1.46) | 2628 | (1.17) | 1999 | (0.89) |
| | 2 | 2381 | (1.06) | 2943 | (1.31) | 2608 | (1.25) | 2336 | (1.04) |
| | 3 | 2336 | (1.04) | 2291 | (1.02) | 2988 | (1.33) | 1757 | (0.80) |
| Plot 35 | 1 | 2858 | (1.29) | 3145 | (1.40) | 3166 | (1.38) | 1842 | (0.82) |
| | 2 | 2696 | (1.20) | 3260 | (1.46) | 3347 | (1.49) | 1820 | (0.81) |
| | 3 | 2336 | (1.04) | 2943 | (1.31) | 2943 | (1.31) | 2044 | (0.91) |
| Plot 20 | 1 | 1752 | (0.78) | 2808 | (1.25) | 2853 | (1.27) | 1572 | (0.70) |
| | 2 | 1820 | (0.81) | 2516 | (1.12) | 2606 | (1.16) | 1842 | (0.82) |
| | 3 | 1752 | (0.78) | 2763 | (1.23) | 2763 | (1.23) | 1820 | (0.81) |
| 20 (gypsum) | 1 | - | (--) | - | (--) | - | (--) | - | (--) |
| | 2 | - | (--) | - | (--) | - | (--) | - | (--) |
| | 3 | - | (--) | - | (--) | - | (--) | - | (--) |
| Check | 1 | - | (--) | - | (--) | - | (--) | - | (--) |
| | 2 | - | (--) | - | (--) | - | (--) | - | (--) |
| | 3 | - | (--) | - | (--) | - | (--) | - | (--) |

Table H3. Yield of alfalfa plots 1982 kg/ha (tons/acre) dry matter.

| Treatment | Site | Cuttings | | | | | | | |
|-------------|------|----------|--------|------|--------|------|--------|------|--------|
| | | 1 | | 2 | | 3 | | 4 | |
| Plot 50 | 1 | 3257 | (1.45) | 3122 | (1.39) | 2561 | (1.14) | 1752 | (0.76) |
| | 2 | 3729 | (1.66) | 2853 | (1.27) | 1602 | (0.74) | 2201 | (0.98) |
| | 3 | 3190 | (1.42) | 2361 | (1.06) | 2808 | (1.25) | 1864 | (0.83) |
| Plot 35G | 1 | 3122 | (1.39) | 3676 | (1.37) | 2675 | (1.28) | 2291 | (1.02) |
| | 2 | 3235 | (1.44) | 2808 | (1.25) | 2763 | (1.23) | 2300 | (1.16) |
| | 3 | 3482 | (1.55) | 2314 | (1.03) | 3033 | (1.35) | 2044 | (0.91) |
| Plot 35 | 1 | 3235 | (1.44) | 3145 | (1.40) | 2538 | (1.13) | 2112 | (0.94) |
| | 2 | 3664 | (1.64) | 2404 | (1.07) | 2426 | (1.08) | 1999 | (0.89) |
| | 3 | 3459 | (1.54) | 2404 | (1.07) | 2561 | (1.14) | 2875 | (1.26) |
| Plot 20 | 1 | 3190 | (1.42) | 2336 | (1.04) | 2561 | (1.14) | 2269 | (1.01) |
| | 2 | 3376 | (1.50) | 3122 | (1.39) | 2628 | (1.17) | 2157 | (0.96) |
| | 3 | 3370 | (1.50) | 2765 | (1.24) | 2361 | (1.06) | 1887 | (0.84) |
| 20 (gypsum) | 1 | - | (--) | 2201 | (0.98) | 2361 | (1.06) | 1820 | (0.81) |
| | 2 | - | (--) | 2361 | (1.06) | 2718 | (1.21) | 2471 | (1.10) |
| | 3 | - | (--) | 2606 | (1.16) | 2246 | (1.00) | 2201 | (0.98) |
| Check | 1 | 1191 | (0.53) | 1415 | (0.63) | 741 | (0.33) | - | (--) |
| | 2 | 1595 | (0.71) | 809 | (0.36) | 1213 | (0.54) | - | (--) |
| | 3 | 1909 | (0.85) | 719 | (0.32) | 1050 | (0.47) | - | (--) |

Appendix I. Rainfall and irrigation frequency and amounts, Huron,
S.D. 1980-1982.

Table II. Rainfall and irrigation dates and amounts (cm).

| May 1980 | | | | | June 1980 | | | | | | |
|-----------|----------|------------|-------|-------|-------------|------|----------|------------|------|------|------|
| Date | Rainfall | Irrigation | | | | Date | Rainfall | Irrigation | | | |
| | | 50 | 35G | 35 | 20 | | | 50 | 35G | 35 | 20 |
| 1 | | | | | | | | | | | |
| 2 | | | | | | 2 | 0.25 | | | | |
| 3 | | | | | | 3 | 1.88 | | | | |
| 4 | | | | | | 4 | 0.13 | | | | |
| 5 | | | | | | 5 | 1.09 | | | | |
| 6 | | | | | | 6 | | | | | |
| 7 | | | | | | 7 | | | | | |
| 8 | | | | | | 8 | | | | | |
| 9 | 0.03 | | | | | 9 | | | | | |
| 10 | 0.46 | | | | | 10 | | | | | |
| 11 | | | | | | 11 | 2.18 | | | | |
| 12 | 0.53 | | | | | 12 | | 2.62 | 2.72 | 5.77 | 2.72 |
| 13 | | 12.70 | 12.70 | 12.70 | 12.70 | 13 | | | | | |
| 14 | | | | | | 14 | 0.05 | | | | |
| 15 | | | | | | 15 | 0.05 | | | | |
| 16 | | | | | | 16 | | 1.80 | 2.82 | 1.80 | 2.82 |
| 17 | | | | | | 17 | | | | | |
| 18 | | | | | | 18 | | | | | |
| 19 | | 9.14 | 9.14 | 8.13 | 8.13 | 19 | | | | | |
| 20 | | | | | | 20 | | 1.27 | 1.78 | 1.27 | 1.78 |
| 21 | | | | | | 21 | 2.24 | | | | |
| 22 | | | | | | 22 | | | | | |
| 23 | | | | | | 23 | 0.15 | | | | |
| 24 | | | | | | 24 | 4.37 | | | | |
| 25 | 0.13 | | | | | 25 | 0.03 | | | | |
| 26 | 0.03 | | | | | 26 | | | | | |
| 27 | | | | | | 27 | | | | | |
| 28 | 0.18 | 5.84 | 4.32 | 3.56 | 2.03 | 28 | | | | | |
| 29 | 1.30 | | | | | 29 | | | | | |
| 30 | 0.46 | | | | | 30 | | | | | |
| 31 | 1.07 | | | | | | | | | | |
| July 1980 | | | | | August 1980 | | | | | | |
| Date | Rainfall | Irrigation | | | | Date | Rainfall | Irrigation | | | |
| | | 50 | 35G | 35 | 20 | | | 50 | 35G | 35 | 20 |
| 1 | | | | | | 1 | | | | | |
| 2 | 2.29 | 5.08 | 4.57 | 3.56 | 3.05 | 2 | | | | | |
| 3 | 0.08 | | | | | 3 | | | | | |
| 4 | 4.19 | | | | | 4 | | | | | |
| 5 | 0.30 | | | | | 5 | 0.08 | 5.59 | 4.01 | 4.06 | 2.44 |
| 6 | | | | | | 6 | 0.03 | | | | |
| 7 | 0.20 | | | | | 7 | 0.41 | | | | |
| 8 | | | | | | 8 | 1.12 | 5.18 | 3.66 | 3.66 | 2.13 |
| 9 | | | | | | 9 | 3.30 | | | | |
| 10 | | 5.33 | 3.91 | 3.81 | 2.39 | 10 | | | | | |
| 11 | | | | | | 11 | | | | | |
| 12 | 0.46 | | | | | 12 | 0.23 | | | | |
| 13 | | | | | | 13 | | 7.87 | 5.33 | 5.33 | 3.05 |
| 14 | 0.18 | | | | | 14 | 0.81 | | | | |
| 15 | | | | | | 15 | 1.78 | | | | |
| 16 | 0.10 | | | | | 16 | | | | | |
| 17 | | | | | | 17 | 1.35 | | | | |
| 18 | 0.30 | | | | | 18 | 0.58 | | | | |
| 19 | 0.05 | | | | | 19 | 0.13 | | | | |
| 20 | | | | | | 20 | | | | | |
| 21 | | | | | | 21 | 0.08 | | | | |
| 22 | | 7.62 | 5.33 | 5.33 | 3.05 | 22 | | 8.23 | 5.69 | 5.69 | 3.28 |
| 23 | | | | | | 23 | | | | | |
| 24 | | | | | | 24 | 0.08 | | | | |
| 25 | | 4.65 | 3.66 | 3.38 | 2.39 | 25 | | | | | |
| 26 | | | | | | 26 | | | | | |
| 27 | | | | | | 27 | | | | | |
| 28 | | | | | | 28 | | | | | |
| 29 | | | | | | 29 | | | | | |
| 30 | | | | | | 30 | | | | | |
| 31 | 0.03 | 6.91 | 4.37 | 5.08 | 2.54 | 31 | 0.03 | | | | |

Table 13. Rainfall and irrigation dates and amounts (cm).

| July 1981 | | | | | August 1981 | | | | | | |
|----------------|----------|------------|------|------|--------------|------|----------|------------|------|------|------|
| Date | Rainfall | Irrigation | | | | Date | Rainfall | Irrigation | | | |
| | | 50 | 35G | 35 | 20 | | | 50 | 35G | 35 | 20 |
| 1 | | | | | | | | | | | |
| 2 | | | | | | 1 | 7.32 | | | | |
| 3 | | | | | | 2 | 0.74 | | | | |
| 4 | | | | | | 3 | 1.42 | | | | |
| 5 | | | | | | 4 | | | | | |
| 6 | | 8.23 | 5.87 | 5.87 | 3.58 | 5 | | | | | |
| 7 | | | | | | 6 | | | | | |
| 8 | | | | | | 7 | | | | | |
| 9 | | | | | | 8 | | | | | |
| 10 | | | | | | 9 | | | | | |
| 11 | | | | | | 10 | | | | | |
| 12 | | | | | | 11 | | 7.57 | 5.28 | 5.28 | 3.00 |
| 13 | 0.10 | | | | | 12 | | | | | |
| 14 | 0.13 | 7.87 | 5.59 | 5.59 | 3.30 | 13 | | | | | |
| 15 | | | | | | 14 | 0.91 | | | | |
| 16 | | | | | | 15 | | | | | |
| 17 | | | | | | 16 | | | | | |
| 18 | | | | | | 17 | | | | | |
| 19 | | | | | | 18 | | 7.75 | 5.46 | 5.46 | 3.18 |
| 20 | | | | | | 19 | | | | | |
| 21 | 0.41 | 7.92 | 5.33 | 5.33 | 3.05 | 20 | | | | | |
| 22 | 1.85 | | | | | 21 | | | | | |
| 23 | 0.13 | | | | | 22 | | | | | |
| 24 | 0.25 | | | | | 23 | 0.91 | | | | |
| 25 | 0.41 | | | | | 24 | | | | | |
| 26 | 0.58 | | | | | 25 | 0.15 | | | | |
| 27 | 0.20 | | | | | 26 | 0.30 | 4.93 | 3.40 | 3.40 | 1.88 |
| 28 | | | | | | 27 | | | | | |
| 29 | | | | | | 28 | | | | | |
| 30 | | | | | | 29 | | | | | |
| 31 | | | | | | 30 | | | | | |
| | | | | | | 31 | | | | | |
| September 1981 | | | | | October 1981 | | | | | | |
| Date | Rainfall | Irrigation | | | | Date | Rainfall | Irrigation | | | |
| | | 50 | 35G | 35 | 20 | | | 50 | 35G | 35 | 20 |
| 1 | | | | | | 1 | | | | | |
| 2 | | | | | | 2 | | | | | |
| 3 | | | | | | 3 | 0.43 | | | | |
| 4 | | | | | | 4 | | | | | |
| 5 | | | | | | 5 | 1.40 | | | | |
| 6 | | | | | | 6 | | | | | |
| 7 | | | | | | 7 | | | | | |
| 8 | | | | | | 8 | | | | | |
| 9 | | | | | | 9 | 0.15 | | | | |
| 10 | | | | | | 10 | | | | | |
| 11 | | | | | | 11 | | | | | |
| 12 | | | | | | 12 | 0.03 | | | | |
| 13 | | | | | | 13 | 1.02 | | | | |
| 14 | 0.20 | | | | | 14 | 0.03 | | | | |
| 15 | 0.03 | | | | | 15 | | | | | |
| 16 | | | | | | 16 | 1.52 | | | | |
| 17 | | 5.44 | 3.66 | 3.66 | 2.21 | 17 | | | | | |
| 18 | | | | | | 18 | | | | | |
| 19 | | | | | | 19 | | | | | |
| 20 | | | | | | 20 | | | | | |
| 21 | | | | | | 21 | | | | | |
| 22 | | | | | | 22 | | | | | |
| 23 | 0.25 | | | | | 23 | | | | | |
| 24 | 0.08 | | | | | 24 | 0.03 | | | | |
| 25 | | | | | | 25 | | | | | |
| 26 | 0.08 | | | | | 26 | | | | | |
| 27 | | | | | | 27 | | | | | |
| 28 | | | | | | 28 | | | | | |
| 29 | | 5.08 | 3.56 | 3.56 | 2.03 | 29 | | | | | |
| 30 | | | | | | 30 | | | | | |
| | | | | | | 31 | | | | | |

Table 14. Rainfall and irrigation dates and amounts (cm).

| May 1982 | | | | | June 1982 | | | | | | |
|-----------|----------|------------|------|------|-------------|------|----------|------------|------|------|------|
| Date | Rainfall | Irrigation | | | | Date | Rainfall | Irrigation | | | |
| | | 50 | 35G | 35 | 20 | | | 50 | 35G | 35 | 20 |
| 1 | | | | | | | | | | | |
| 2 | | | | | | | | | | | |
| 3 | | | | | | | | | | | |
| 4 | | | | | | | | | | | |
| 5 | | | | | | | | | | | |
| 6 | | | | | | 6 | 0.76 | | | | |
| 7 | | | | | | 7 | | | | | |
| 8 | | | | | | 8 | 0.51 | 6.05 | 3.20 | 3.20 | |
| 9 | 0.74 | | | | | 9 | | | | | |
| 10 | 1.14 | | | | | 10 | | | | | |
| 11 | 1.93 | | | | | 11 | 0.10 | | | | |
| 12 | 0.71 | | | | | 12 | | | | | |
| 13 | 1.12 | | | | | 13 | | | | | |
| 14 | 0.61 | | | | | 14 | 0.58 | | | | |
| 15 | 0.18 | | | | | 15 | | | | | |
| 16 | 0.10 | | | | | 16 | 0.76 | | | | |
| 17 | 0.03 | | | | | 17 | 0.05 | 3.58 | 1.91 | 1.91 | |
| 18 | | | | | | 18 | | | | | |
| 19 | | | | | | 19 | | | | | |
| 20 | 0.13 | | | | | 20 | | | | | |
| 21 | 0.15 | | | | | 21 | | | | | |
| 22 | | | | | | 22 | | | | | |
| 23 | | | | | | 23 | | | | | |
| 24 | 0.18 | | | | | 24 | 0.13 | 6.02 | 2.46 | 2.46 | 4.19 |
| 25 | 1.45 | | | | | 25 | | | | | |
| 26 | 0.69 | | | | | 26 | | | | | |
| 27 | | | | | | 27 | | | | | |
| 28 | 0.05 | | | | | 28 | | | | | |
| 29 | 0.25 | | | | | 29 | | | | | |
| 30 | 2.18 | | | | | 30 | 0.28 | 8.66 | 6.38 | 6.38 | 1.63 |
| 31 | | | | | | | | | | | |
| July 1982 | | | | | August 1982 | | | | | | |
| Date | Rainfall | Irrigation | | | | Date | Rainfall | Irrigation | | | |
| | | 50 | 35G | 35 | 20 | | | 50 | 35G | 35 | 20 |
| 1 | | | | | | | | | | | |
| 2 | 0.30 | | | | | 1 | | | | | |
| 3 | | | | | | 2 | | | | | |
| 4 | | | | | | 3 | 0.25 | 5.97 | 4.14 | 4.14 | |
| 5 | | | | | | 4 | | | | | |
| 6 | 0.56 | | | | | 5 | | | | | |
| 7 | | 3.78 | 2.64 | 2.64 | | 6 | | | | | |
| 8 | | | | | | 7 | | | | | |
| 9 | | | | | | 8 | | | | | |
| 10 | | | | | | 9 | | | | | |
| 11 | | | | | | 10 | | 7.62 | 5.33 | 5.33 | 9.14 |
| 12 | | | | | | 11 | | | | | |
| 13 | | 9.58 | 1.85 | 1.85 | | 12 | | | | | |
| 14 | 0.86 | | | | | 13 | | | | | |
| 15 | 3.58 | | | | 5.59 | 14 | | | | | |
| 16 | | | | | | 15 | | | | | |
| 17 | | | | | | 16 | | | | | |
| 18 | | | | | | 17 | | | | | |
| 19 | 0.10 | | | | | 18 | | | | | |
| 20 | 2.29 | | | | | 19 | | 7.65 | 5.31 | 5.31 | |
| 21 | 0.03 | | | | | 20 | | | | | |
| 22 | | | | | | 21 | | | | | |
| 23 | | 3.18 | 0.79 | 0.79 | | 22 | 0.33 | | | | |
| 24 | | | | | | 23 | 0.74 | | | | |
| 25 | 0.08 | | | | | 24 | 0.58 | | | | |
| 26 | 4.57 | | | | | 25 | | 5.31 | 3.38 | 3.38 | |
| 27 | | 2.18 | 2.18 | 2.18 | | 26 | | | | | |
| 28 | 0.58 | | | | | 27 | | | | | |
| 29 | | | | | | 28 | | | | | |
| 30 | | | | | | 29 | 0.74 | | | | |
| 31 | | | | | | 30 | 0.99 | | | | |
| | | | | | | 31 | 3.61 | | | | |

Table I5. Rainfall and irrigation dates and amounts (cm).

| September 1982 | | | | | |
|----------------|----------|------------|------|------|------|
| Date | Rainfall | Irrigation | | | |
| | | 50 | 35G | 35 | 20 |
| 1 | | | | | |
| 2 | | | | | |
| 3 | | 3.71 | 2.18 | 2.18 | |
| 4 | | | | | |
| 5 | | | | | |
| 6 | | | | | |
| 7 | | | | | |
| 8 | | | | | |
| 9 | 0.23 | 5.08 | 3.56 | 3.56 | 6.20 |
| 10 | | | | | |
| 11 | 2.13 | | | | |
| 12 | 2.13 | | | | |
| 13 | | | | | |
| 14 | | | | | |
| 15 | 0.58 | | | | |
| 16 | | | | | |
| 17 | | | | | |
| 18 | | | | | |
| 19 | | | | | |
| 20 | | | | | |
| 21 | | | | | |
| 22 | | | | | |
| 23 | | | | | |
| 24 | | | | | |
| 25 | | | | | |
| 26 | | | | | |
| 27 | | | | | |
| 28 | | | | | |
| 29 | | | | | |
| 30 | 0.36 | | | | |